



INSTRUCTION MANUAL

TESTING TABLE

MODEL 03-00039A

NOISE LABORATORY CO., LTD.

3.03 edition
AEM00002-00E-2D

NOTICE

- The contents of this instruction manual are subject to change without prior notice.
- No part of this instruction manual may be reproduced or distributed, in any form or by any means, without the authorization of Noise Laboratory Co., Ltd.
- The contents of this instruction manual have been thoroughly examined. However, if you find any problems, misprints, or missing information, please feel free to contact our sales agent who you purchased our product from.
- Noise Laboratory Co., Ltd. assumes no responsibility for any loss or damage resulting from improper usage, failure to follow this instruction manual, or any repair or modifications of this product undertaken by a third party other than Noise Laboratory Co., Ltd. or its authorized person.
- Noise Laboratory Co., Ltd. assumes no responsibility for any loss or damage resulting from remodeling or conversion solely undertaken by the user.
- Please note that Noise Laboratory Co., Ltd. cannot be held responsible for any consequences arising from the use of this product.

1. IMPORTANT SAFETY PRECAUTIONS

The following instructions form an integral part of this product and must be available to the operating personnel at all times. All the safety instructions and advice notes are to be observed. This instruction manual should be kept the place the operator can always consult it.

- **This product is originally intended to be used as a ready ESD test test-up for table-top equipment to the EN/IEC 61000-4 standard. Do not use this product for any purposes other than the EMC testing purposes.**
- **As for the handling of test equipment, its peripheral equipment and EUT (Equipment Under Test), refer to the instruction manual of each equipment.**

A number of safety recommendations are listed in "Basic safety precautions" mentioned later. Be sure to read them before setting a test environment, connection and starting a test.

2. APPLICATION FORM FOR INSTRUCTION MANUAL

To: Noise Laboratory Co., Ltd.

We place an order for an instruction manual.

Product: Testing table

Model: 03-00039A

Applicant:

Company name: _____

Address: _____

Department: _____

Person in charge: _____

Tel No.: _____

Fax No.: _____

**Cut off this page "APPLICATION FORM FOR INSTRUCTION MANUAL"
from this volume and keep it for future use with care.**

When an INSTRUCTION MANUAL is required, fill in the above Application Form and mail or fax it to the following sales department of our company.

To: Noise Laboratory Co., Ltd.
1-4-4 Chiyoda Sagami-hara City,
Kanagawa Pref., 229-0037 Japan
Tel: +81-(0)42-712-2051 Fax: +81-(0)42-712-2050

Cut line

3. CONTENTS

1. IMPORTANT SAFETY PRECAUTIONS	1
2. APPLICATION FORM FOR INSTRUCTION MANUAL	3
3. CONTENTS	5
4. PREFACE	6
5. BASIC SAFETY PRECAUTIONS	8
5-1. Hazard symbols	8
5-2. Fundamental Safety Precautions	8
6. SPECIFICATIONS	10
7. LIST OF COMPONENTS OF 03-00039A	11
8. ASSEMBLING INSTRUCTION	12
9. OPERATING PRECAUTIONS	15
10. TEST CONFIGURATION (INFORMATIVE)	16
11. OPTION	18
12. WARRANTY	19
13. MAINTENANCE	21
14. NOISE LABORATORY SUPPORT NETWORK	21

4. PREFACE

We thank you very much for your purchase of the Electrostatic Discharge Immunity Test Environment Model: 03-00039A.

This Test Environment Model: 03-00039A is one part of testing equipment used for discharge immunity tests for table-top type equipment in accordance with IEC (International Electro technical Commission) 61000-4-2 standards. And besides, it is also used for other commonly conducted methods for EMC immunity test (e.g. impulse noise test) with the horizontal coupling plane on it.

This instruction manual describes how to assemble the test table 03-00039A and its usage with example of electrostatic discharge test based on the standard IEC61000-4-2. For better understanding for safe and proper test method, refer to the above standard as well as this manual.

- **This instruction manual is prepared so that any person who can observe the prescribed test method and operating precautions may safely handle and fully utilize this testing table (Model 03-00039A).**
- **This instruction manual describes the basic construction, specification, and assembling way of this product as well as the configuration of the related equipment for ESD immunity test. Keep this manual by your side or other proper location so that it may be readily available when using the 03-00039A.**
- **For floor-standing equipment, the other ready-made insulation pallet MODEL: 03-00024A and the vertical coupling plane base MODEL: 03-00034A is readily available as the optional product for the NoiseKen simulators.**

Features

1. In combination with the NoiseKen ESD simulator, this product offers a ready-made test environment for immunity tests for table-top equipment as per the EN/IEC61000-4 standard.
**Install the optional horizontal coupling plane depending on the necessity prescribed in the related standards.
2. Made by wood, the test table minimizes the loss of energy produced by the simulator, leading to reproducible tests.

5. BASIC SAFETY PRECAUTIONS

5-1. Hazard symbols



It expresses a WARNING.

WARNING indicates a potentially hazardous situation which, if not avoided, could result in **death or serious injury**.

【WARNING labels may be present on the associated equipment you use. Please be sure to refer to the safety precautions provided in the relevant product manual.】



It expresses a CAUTION.

CAUTION indicates a potentially hazardous situation which, if not avoided, may result in **minor or moderate injury**.

5-2. Fundamental Safety Precautions



1. This product shall be assembled before use. For assembling, follow the assembling instructions shown in a later part of this manual. Assembling can be performed only in a safe place and by two or more persons. Follow the general safety instructions of the users' work place. Working in an inappropriate environment may lead to an injury.
【Precautions for human body, environment and safety】
2. The top board of the test table must be fixed to the legs with the blocks. However, when relocating the product, check that the top board has been firmly fixed. If the top board has not been not firmly fixed, it may come off from the legs, resulting in a danger. Before carrying the table, unload all items from it first. Carriage shall be done by two or more persons.
【Precautions for handling and safety】
3. Install the test table on a flat floor surface. After installation, check to see that the 4 legs are in touch with the floor evenly and that it is in equilibrium as a test table.
【Precautions for installation and environment】
4. This product is capable of withstanding up to 100kg. Never exceed this load limit. Avoid concentrating loads to the edges of the table. Never apply strong shock or power in the horizontal direction.
【Precautions for handling】

⚠ CAUTION 注意

5. Never step on or sit on the table. Never use the product as unintended.
【Precautions for handling】
6. This product is made of wood. Avoid using or storing this product in a high or low temperature, or high humidity environment. (Operating temperature range: 15~35°C/ Operating humidity range: 25~75%). Never put any device which generates fire, high heat or vapor on or in proximity to the table. Never expose it to liquid, such as chemicals, or gas.
【Precautions for handling, installation, and environment】
7. To ensure the safe and correct procedure of EMC tests, the contents of this manual should be thoroughly understood and used as a ready reference for operation. It is also recommended to read this Instruction Manual together with the instruction manuals of test equipment being used, for example, an electrostatic discharge simulator, a noise simulator and so on, as well as related standards.
【Precautions for human body, operation, environment and connection】
8. Do not wipe this product with thinner, alcohol or other solvent. When the body is dirty, soak a cloth into neutral detergent, squeeze out the detergent from the cloth and wipe the body with the cloth.
【Precautions for handling】
9. When repair, maintenance work or internal adjustment is required, our company's service engineer or our designated service engineer takes charge of such work.
【Precautions for handling and environment】
10. Our company and sales agents shall have no responsibility for any accident resulting in injury or death, any breakage or resultant damages due to irresponsible handling.
【Precautions for human body, operation, environments and connection】

6. SPECIFICATIONS

Description of the product : Testing table

Model : 03-00039A

Dimensions : (W)1600x(H)800x(D)800mm

Material : Lauan plywood (Top board) / Poplar (Legs, Beam)

Weight : 22kg

Weight proof : 100kg (Uniformly distributed static load)

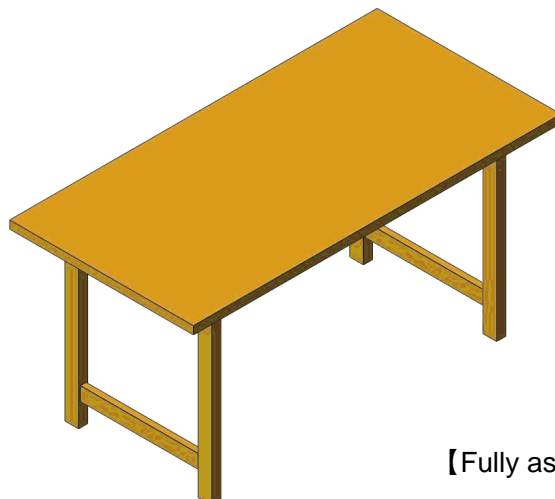
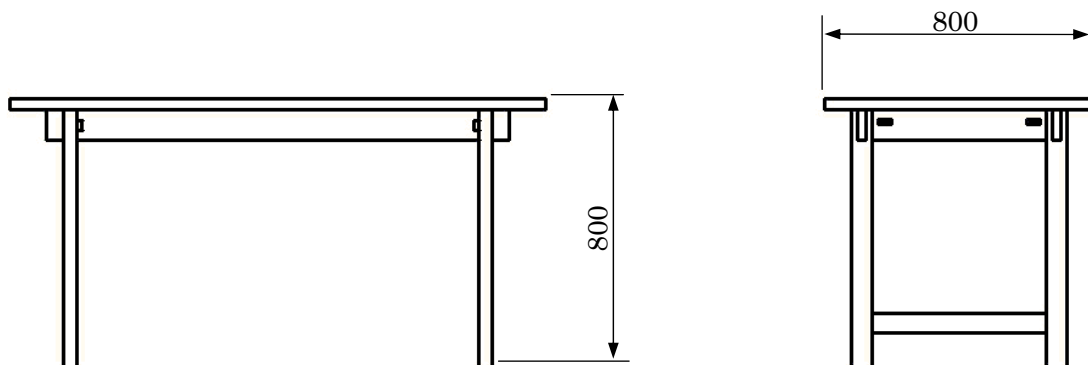
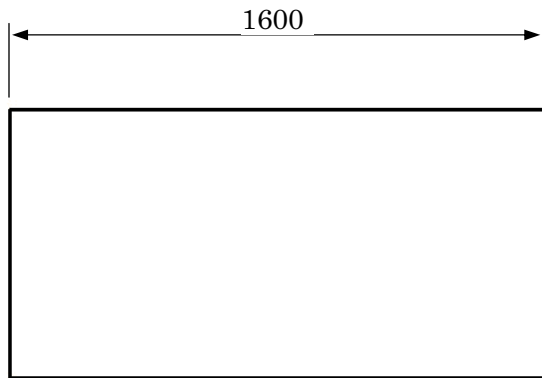

【Fully assembled】

7. LIST OF COMPONENTS OF 03-00039A

Confirm all components on the below list are prepared before assembling this product.

- ① Top board of testing table 1 pc.
- ② Testing table legs 2 pcs.
- ③ Testing table legs beam 2 pcs.
- ④ Retaining Block 4 pcs.
- ⑤ Wedge 4 pcs.
- ⑥ Instruction manual 1 pc.

※The optional Horizontal coupling plane is fixed to the top board of testing table before shipment if the customer purchases both of them at the same time.

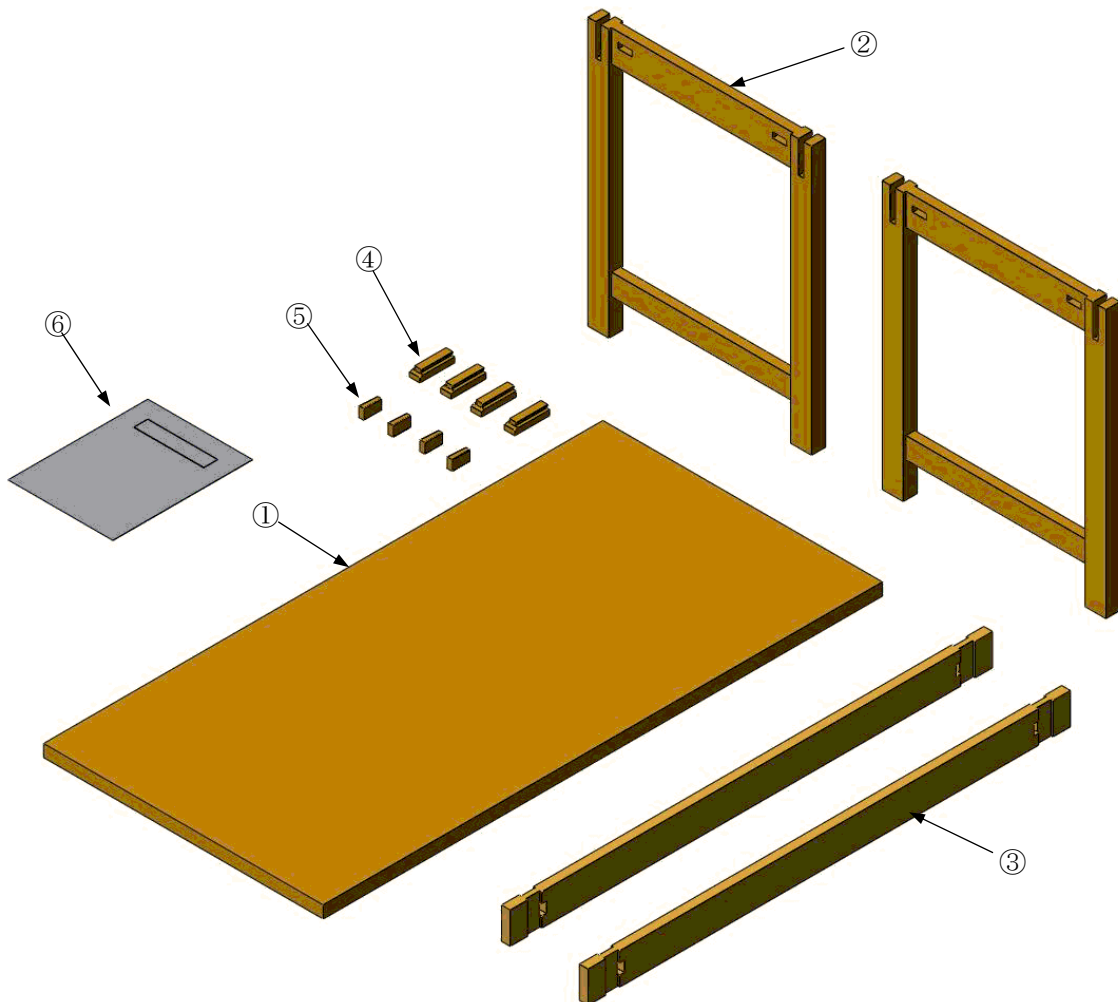

8. ASSEMBLING INSTRUCTION

- ① Insert the beams to the grooves of the legs (Beams have no direction).

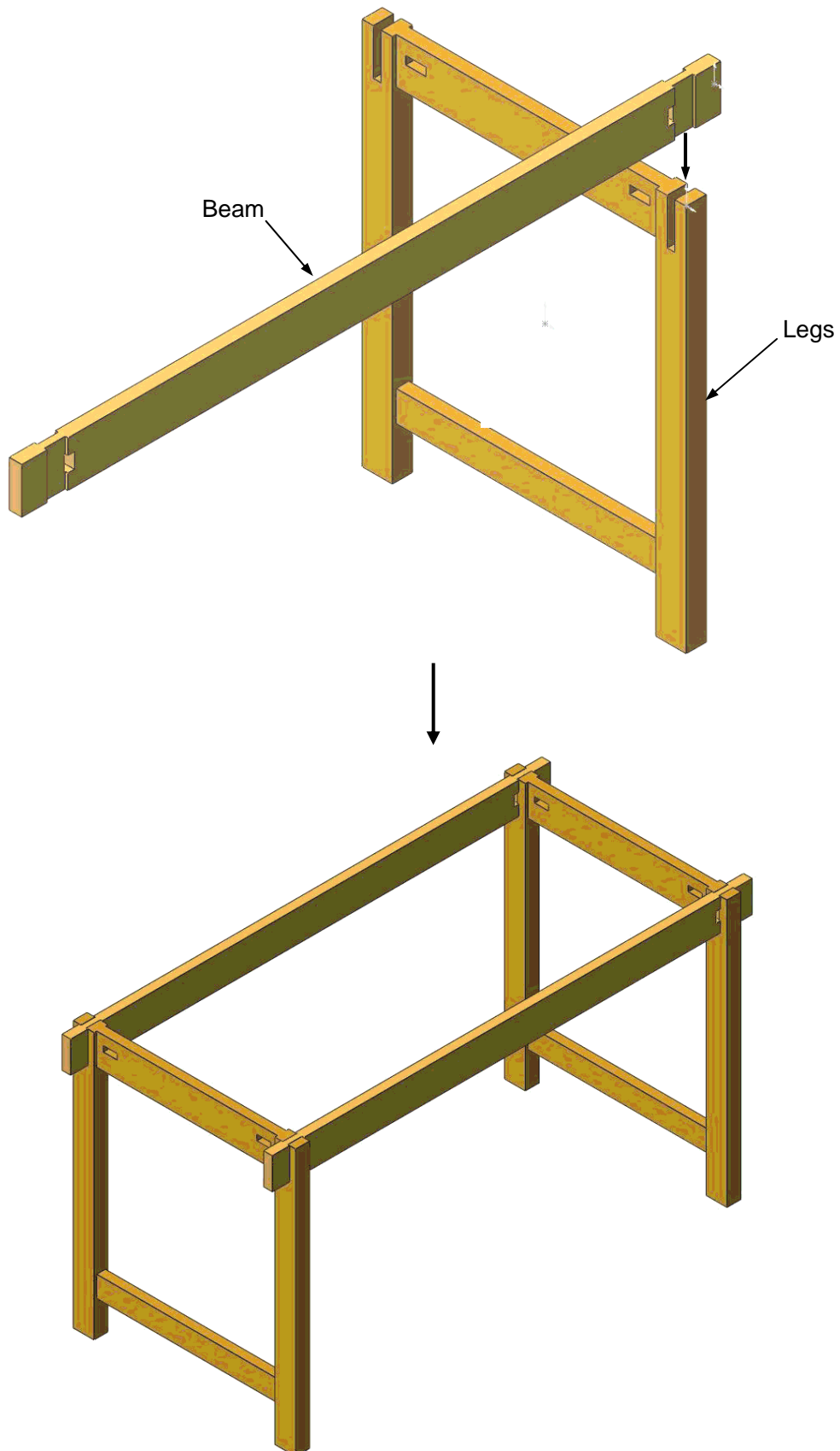

- ② Insert the retaining blocks to the rails at each corner of the backside of the top board. Each block shall be firmly inserted to the half-depth with the projection outwards.

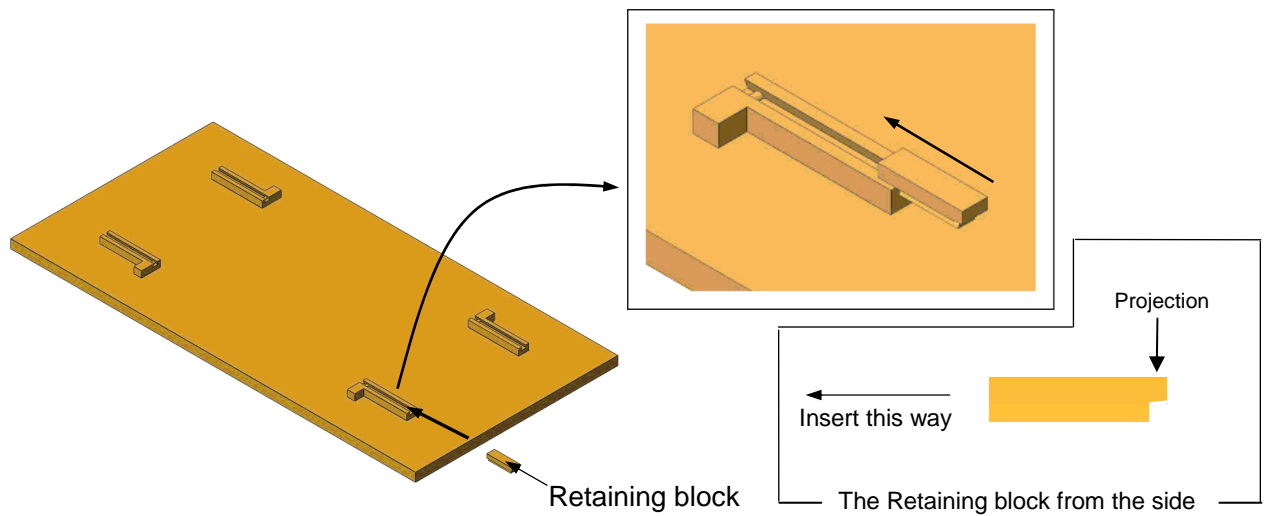

- ③ Put the top board on the legs assembled in step ① (The rails are to be positioned within the legs).
- ④ Following the step ③, manually insert the retaining blocks to the angle holes of the legs, to their dept.

Important : Be sure to proceed with all four corners. Work in the correct manner, otherwise, the top board will slip, leading to danger with the personnel.

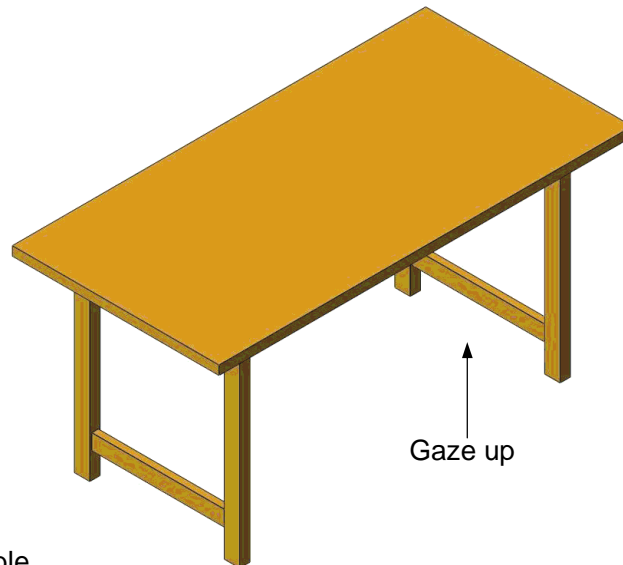

From beneath the table

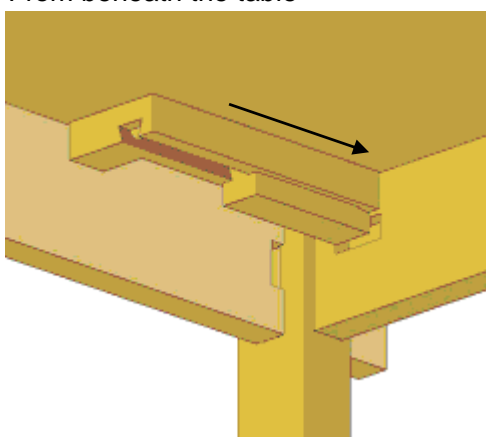

Insert blocks to angle holes firmly with ensuring fitting is right.

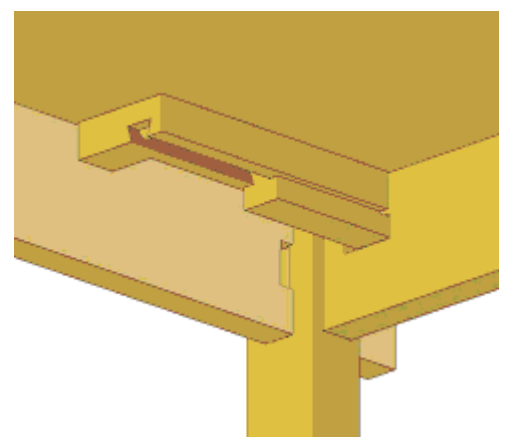

⑤ Manually insert the wedges to the angle holes of the beams. Proceed for all four corners.

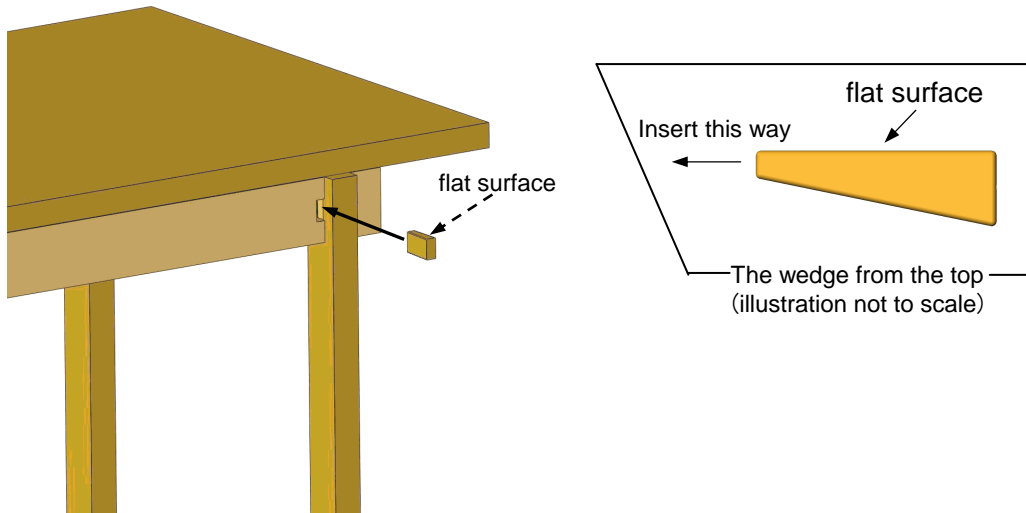

⑥ Hit the wedges with a plastic hammer.
Important : Hard hitting may cause damages to the product.

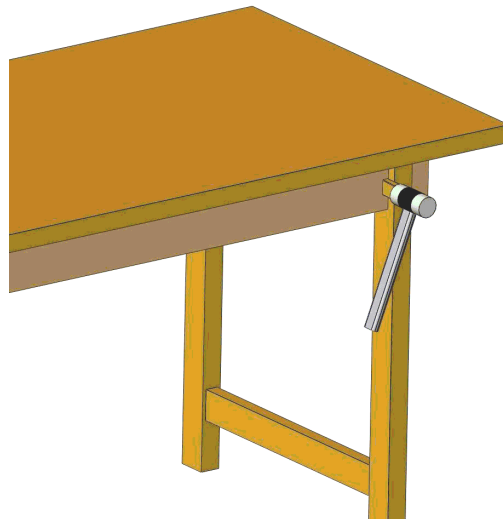

⑦ Now the product has been fully assembled. Check to see that there is no jounce.

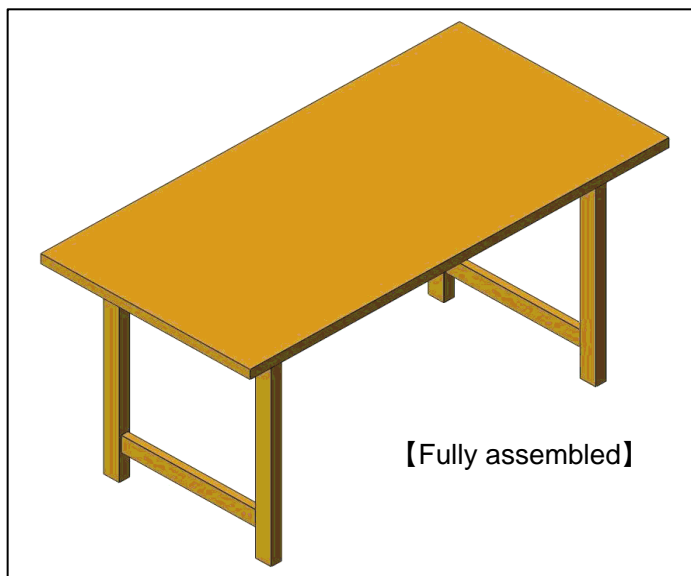

9. OPERATING PRECAUTIONS

To ensure safety, the following advices shall be observed.

1. Install the test table on a flat floor surface. After installation, check to see that the 4 legs are in touch with the floor. If the floor is tilted or bumpy, the table may jounce, which may lead to a drop of the object put on the table.
2. The top board of the test table must be fixed to the legs with the blocks. However, when relocating the product, check that the top board has been firmly fixed. If the top board has not been firmly fixed, it may come off from the legs, resulting in a danger.
3. The test table is capable of withstanding up to 100 kg. Never exceed this load limit. Avoid concentrating loads to the edges of the table. Never apply strong shock or power in the horizontal direction. If you step or sit on the test table, you may suffer an injury.
4. For the test table, periodic checks are recommended for the wedges and retaining blocks that there is no irregularity.
5. To ensure the safe and correct procedure of EMC tests, the contents of this manual should be thoroughly understood and used as a ready reference for operation. It is also recommended to read this instruction manual together with the instruction manuals for the associated products.

10. TEST CONFIGURATION (INFORMATIVE)

The example of test configuration of electrostatic discharge immunity test is described as under.
(The commodity name with [] bracket indicates that it is the optional products of this product.)

Test configuration for table-top equipment as per the EN/IEC 61000-4-2

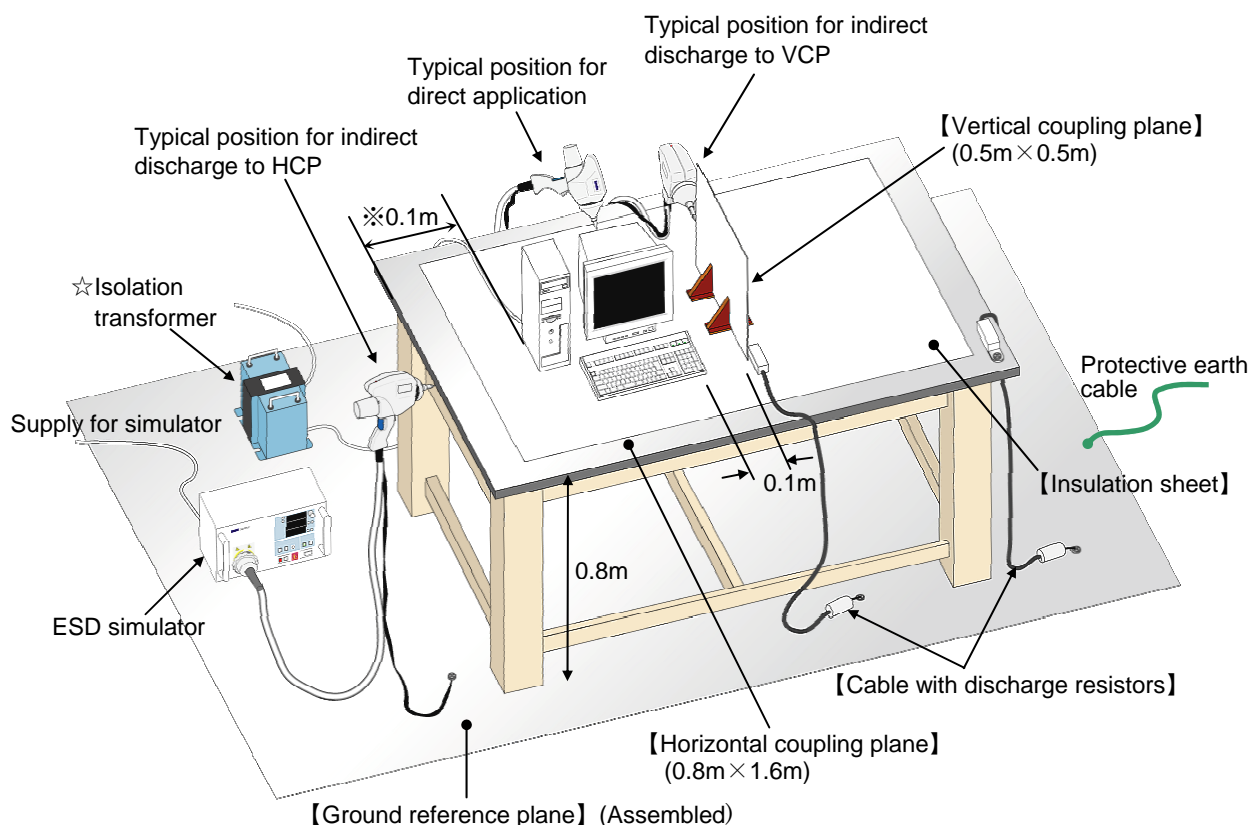

Fig 1. Example of test configuration

1. Put the test table on the ground plane.

*****Notice:** The EN / IEC 61000-4-2 standard does not prescribe where the ground plane should be laid out in a test room, but prescribes the position of EUT which is put on the test table as it should be at least 0.8m away from the wall of the test room and any metallic structure. As the length of the long side of the ground plane is 1.8m, if the ground plane is laid out along the edge of the test room, the distance between EUT and the wall is sometimes less than 0.8m. Take this matter into consideration when the ground plane is laid out.

✖As for the distance from the wall, EN/IEC61000-4-2 (Edition 2.0) standard prescribes it should be "more than 0.8m" with having revised "more than 1m" on the previous version of the standard.

2. Ground the ground plane to the protective earth terminal of the test room with an appropriate cable. Use M4 hole or M3 screw hole for connecting the protective earth cable.



If your test room has no protective earth terminal, set up new one with asking a qualified contractor. Never use an internal plumbing such as gas pipe, a water pipe, or so on, to substitute PE terminal, since it may cause fire or explosion or it may not be grounded actually.

3. Put the assembled test table on the ground plane and put the horizontal coupling plane on the table. Peel off protective film of the horizontal coupling plane completely.
(The horizontal coupling plane is usually installed on the top board of the table when it is shipped out.)
4. Connect a discharge cable to the horizontal coupling plane and ground plane with a screw M4 with a washer.
5. Put the insulation sheet (after peeling off protective film) in the center of the horizontal coupling plane. Put the EUT on the sheet. The position of EUT should be on the insulation sheet and 0.1m away from the edge of the horizontal coupling plane.
***Notice: In the Fig1. EUT is put on the position more than 0.1m away from the edge just to make the figure more understandable.
6. In case of conducting the indirect discharge test, put the vertical coupling plane on the insulation sheet on the position 0.1m away from EUT. Connect the vertical coupling plane to the ground plane with a discharge cable with using a screw M4 with a washer.
The center adopter can be used as a positional guide for the indirect discharge test with installing it onto the tip of the conical tip and inserting the vertical coupling plane into the ditch of it.
7. Use the isolation transformer (NoiseKen NCT series Noise Canceller Transformer recommended) for AC line of EUT if necessary.
☆In the EN/IEC 61000-4-2 standard, inserting the isolation transformer is not allowed, but in the JIS C 61000-4-2, the case that isolation transformer is necessary with taking Japan's situation of commercial power supply and EUT specification into consideration is prescribed.
8. Put the electrostatic discharge simulator on the ground plane. Putting it on the horizontal coupling plane is not allowed.
9. Connect the ground lead of the discharge gun to the ground plane. The M4 hole of the ground plane can be used as the terminal for connection but there can be some cases that ground cable cannot reach to the hole because of positioning of the gun and EUT. In such a case, set a new terminal on the convenient position on the ground plane with using a screw or a braid.

[Supplementary]

In some cases of testing of the EUT which does not have any ground line, such as battery drive products, the EUT itself is charged with ESD injection, the effect of discharge is diminished, and as a result, the validity of the test can be lost. To prevent such a situation, The EN/IEC 61000-4-2 standard prescribes discharging (eliminating electricity) on every ESD test. The discharge cable of this product can be used as a cable for eliminating electricity.

And, besides, in case of the EUT which has a nonconductive body, such as plastic, and metal connector shells to be discharged in ESD test, injecting ESD with connecting a discharge cable to the injection point is allowed. In such a case, direction of the discharge cable is prescribed. In case of using the discharge cable of this product for such a case, connect a resistor in a quadruple prism shape case to the injection point, a solderless terminal of the tip of the cable of a column shape case side to the horizontal coupling plane.

When the result of the test is different depending on eliminating way, the result of the test of eliminating on every discharge is first considered.

11. OPTION

Noise Laboratory is preparing the products for conducting the electrostatic discharge immunity test described in the standard IEC61000-4-2. The basic product lineup is as follows.

Electrostatic discharge simulator ESS-2000AX, 2002EX, 2000, 2002

Discharge gun TC-815R

【Option】

Insulation sheet 03-00004A

Vertical coupling plane 03-00005A

Horizontal coupling plane 03-00020A

Ground plane 03-00007A

Cable with discharge resistors 05-00054B

Center adaptor 03-00023A

Please contact our sales agent or us when you need other products.

The above products are subject to change or to be discontinued without prior notice.

12. WARRANTY

Servicing terms

The following terms are applicable to servicing by Noise Laboratory Co., Ltd., (hereafter referred to as the Company) provided to maintain the intended performance of its products.

1. Scope

The following terms shall apply only to products made by the Company.

2. Technical servicing fee

In the event of a failure of a product within the warranty period (see warranty section), the Company will repair a product without charge. After the warranty expires, repairs will be billed at a nominal cost.

3. Ownership of defective parts

Any defective part exchanged under the Company's servicing belongs to it.

4. Limited liability

In the event that damages resulting from servicing by the Company are intentional or caused by negligence, the Company will pay the cost but at the purchase value of the relevant product maximum. But, notwithstanding the foregoing, the Company shall not be responsible for any incidental or consequential damages of any nature, including without limitation thereof loss of would-be profit or compensation demanded from a third party

5. Refusal to offer servicing

The company may not accept a repair order in the following cases:

- More than 5 years have passed since the product discontinued
- More than 8 years have passed after delivery
- Required component for servicing already discontinued and no alternative is available.
- Product changed, repaired or remodeled without obtaining a prior permission from the Company.
- Product severely damaged to the extent it has lost its original form

Limited warranty

Noise Laboratory Co., Ltd. (hereafter referred to as the Company) warrants its products to be free from defects in materials and workmanship under normal use and service for a period of one year from date of delivery. In the event of failure of a product covered by this warranty, the Company will repair the product or may, at its option, replace it in lieu of repair without charge.

Notwithstanding the foregoing, the Company shall not be responsible for any incidental or consequential damages of any nature, including without limitation thereof loss of would-be profit or compensation demanded from a third party. This warranty is valid only in Japan.

1. Scope

This warranty shall only apply to products made by the Company.

2. Period

One year from date of delivery. The warranty may be valid in 6 months after servicing if the same failure on the same component has repeated.

3. Exclusions

The followings are exclusions from this warranty:

- Consumable parts (including HV relay)
- Failure caused by misuse, neglect, accident or abnormal conditions of operation
- Failure caused by remodeling on the user side without prior permission from the Company
- Failure caused by servicing by unauthorized personnel by the Company
- Failure due to force majeure including but not limited to, acts of God, fire, war, riot, rebellion and others
- Failure due to shock or drop in or after transit
- Failure due to operation in environment being out of ambient specifications.
- A unit shipped to overseas.

13. MAINTENANCE

1. When repair, maintenance or some kind of adjustment of the unit is required, a qualified service engineer takes charge of such work.
2. Do not take apart this product more than the status which it is shipped.
3. Maintenance on the user side is restricted to the outside cleaning and functional check of the unit.
4. When cleaning the unit, turn off the switch of the related equipment, disconnect the plug socket, and move the related equipment to the convenient place for working beforehand.
5. Avoid using chemicals for cleaning. Otherwise, the coating of the unit may peel off or the sight glass may be broken.

14. NOISE LABORATORY SUPPORT NETWORK

- If a symptom that seems a trouble is found, check the symptom against the following check sheet and inform the model name and serial Number of the product together with the symptom to Noise Laboratory or our nearest sales agent in your area.
- When the product is returned to Noise Laboratory, write the state of the trouble, contents of your request, model name and serial number in a repair order, pack the product and repair order sheet in the former package or equivalent suitable for transit, and send them back.

NOISE LABORATORY CO., LTD.

1-4-4, Chiyoda, Sagamihara City, Kanagawa Pref., 229-0037, Japan

TEL: +81-(0)42-712-2051 FAX: +81-(0)42-712-2050

URL: <http://www.noiseken.co.jp>

Printed in Japan