

NoiseKen

INSTRUCTION MANUAL

NO LOAD WAVEFORM

VERIFICATION ATT

00-00007A

NOISE LABORATORY CO., LTD.

Edition 1.01
AEJ00375-00E-0B

CONTENTS

1. IMPORTANT SAFETY PRECAUTIONS	1
2. PREFACE	1
3. BASIC SAFETY PRECAUTIONS	1
4. ENCLOSED ITEMS	2
5. OPERATION	3
6. SPECIFICATIONS	4
7. WARRANTY	5
8. MAINTENANCE	6
9. SUPPORT NETWORK	6
10. APPLICATION FORM	7

1. IMPORTANT SAFETY PRECAUTIONS

As this product is an attenuator to observe waveform of pulse generated by a pulse generator, it is always used with pulse generators. Read the instruction manuals of those pulse generators carefully, and fully understand matters about safety handling prior to usage.

2. PREFACE

We thank you for your purchasing No Load Waveform Verification ATT MODEL: 00-00007A (hereinafter "the Unit"). Read this instruction manual ("the Manual") carefully prior to usage, thoroughly understand the contents of the Manual and use as ready reference for operation.

- The Manual will help you operate the Unit safely and make the most of use it, if you strictly follow the operational procedures and safety instructions.
- Keep the Manual where it is readily available.
- The Unit is an attenuator used for observing waveforms of fast rise time pulses, e.g. test pulse 3a and 3b prescribed in ISO7637-2.

§ FEATURES

1. Attenuates pulse voltage in the attenuation ratio 100:1.
2. Pulse withstanding voltage: 1kV
3. Wide frequency range: DC~500MHz
4. Keeps higher impedance in high frequency range with input resistance 2475Ω and power capacity less than 2.0pF.
That prevents load down in measurement and suppress the ringing phenomenon which is caused by input capacitance and ground lead, considered as a problem in measurement by a probe.

3. BASIC SAFETY PRECAUTIONS

1. Mishandling or careless operation may result in a fatal wound. 【Precautions for human body, operation, environments and connection】
2. When connecting the Unit to a pulse generator, be sure to stop the pulse output of the generator. Otherwise, you may get an electric shock. 【Precautions for human body and connection】
3. Fully put in each coaxial connector and make sure connection by rotating it clockwise until a "click" is heard. 【Precautions for human body and connection】
4. Our company and sales agents shall have no responsibility for any accident resulting in injury or death, any breakage or resultant damages due to irresponsible handling. 【Precautions for human body, operation, environments and connection】
5. If the Unit is used in conditions exceeding its tolerance level, it may result in not only damage or deterioration of characteristics of the Unit but also an electric shock to human body. 【Precautions for human body and connection】
6. The attenuation ratio of the Unit is 100:1. Take into consideration allowable input voltage of each

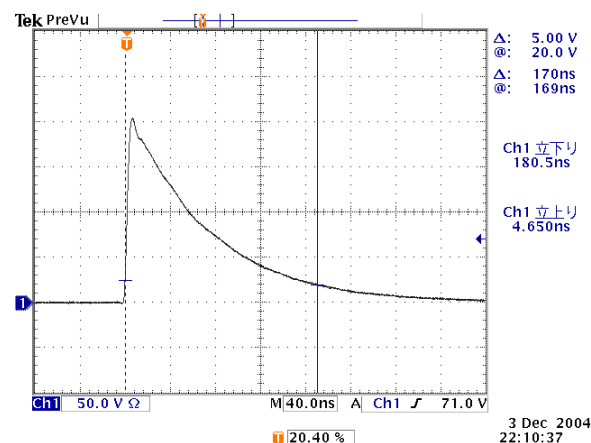

P3b Waveform

of

measurement equipment, e.g. an oscilloscope. If the value to be measured exceeds allowable limit, put one more 50Ω attenuator between the Unit and the oscilloscope.

4. ENCLOSED ITEMS

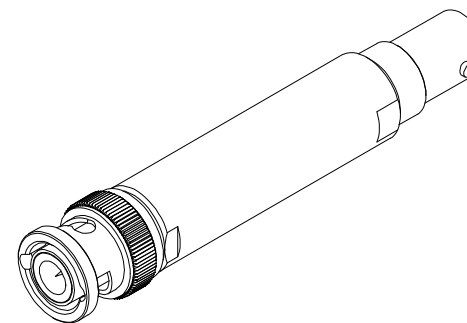

No Load Waveform Verification ATT 1 piece

5. OPERATION

For details, refer to "WAVEFORM VERIFICATION" of the instruction manual of ISS-7600 or ISS-7630.

1. Preparation of equipment

- The following description is the example of connecting of the Unit to ISS-7630. The Unit can also be used for ISS-7690 (P3a, P3b waveform) in the same way.
- For an AC cable of measurement equipment, such as an oscilloscope, prepare a 2P cable without PE.
- For waveform verification conforming to the ISO 7637-2 standard, connect between "+" and "-" of DC input terminal of ISS-7630 with the short lead cable (one of the accessories of ISS-7630) to make the terminals short-circuited.
- Be sure to turn ON the breaker of ISS-7630 (Turn up the lever).
- Insert the BNC conversion adaptor (one of the accessories of ISS-7630) into "output terminal (HOT, GND) of ISS-7630. Be sure to confirm that the adaptor is inserted into the right position.

2. Connection between ISS-7630 and the Unit

- Connect No Load waveform verification ATT to the BNC conversion adaptor. The attenuation ratio is 100:1.

Notice

In attaching and removing the connector, be sure to confirm a pulse is not generated.

3. Connection between measurement equipment and the Unit

- Connect the 50Ω coaxial cable with BNC (one of the accessories of ISS-7630) to the Unit.
- Connect the other end of the 50Ω coaxial cable with BNC to measurement equipment, such as an oscilloscope.

4. Setup of measurement equipment

- Terminate measurement equipment, such as an oscilloscope internally with 50Ω.
- If pulse output voltage of ISS-7630 Us is set as 350V, voltage at 50Ω termination in measurement equipment will be 3.5V.

Notice

- Consider the rated input voltage of measurement equipment.
If the value exceeds the rated input voltage value, put one more 50Ω attenuator between the Unit and the oscilloscope.
- Is the input impedance of measurement equipment 50Ω?
As the output impedance of the Unit is 50Ω, make the input impedance of your measurement equipment 50Ω also. In case of using high impedance input measurement equipment (e.g. 1MΩ), put a 50Ω non-reflective terminator onto the input part of your measurement equipment.

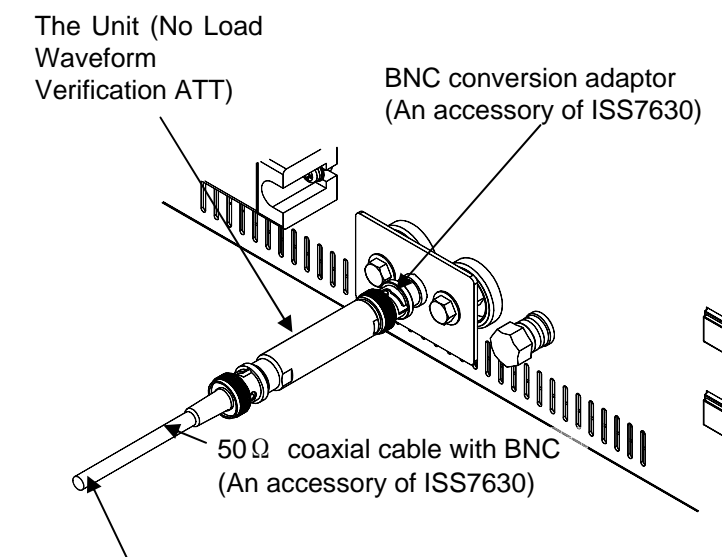

To measurement equipment, such as an oscilloscope Connection (50Ω non-reflective terminator)

6. SPECIFICATIONS

Product name..... No Load Waveform Verification ATT
 Model name..... 00-00007A

ITEMS		SPECIFICATIONS
Attenuation Ratio		DC~500MHz-----40dB (Tolerance : 39.7dB~43.0dB*) DC~100MHz-----40dB (Tolerance : 39.7dB~40.3dB*) ※In DC 1/100 ±2.5%
Input	Peak voltage	1kV at 1μs 1kV at P3a, P3b
	Resistance	2475Ω (50Ω termination at output side)
	Capacitance	Less than 2.0pF (50Ω termination at output side)
	Power	2W (Less than 25°C)
	Shape	BNC-P (male)
Output	Resistance	49Ω (50Ω termination at input side)
	VSWR	Less than 1.2 (~1GHz, 50Ω termination at input side)
	Shape	BNC-J (female)
Weight		Approximately 50g

Notice

In case of injecting pulse on to DC, fully consider the power consumption at No Load Waveform verification ATT.

【Appearance】

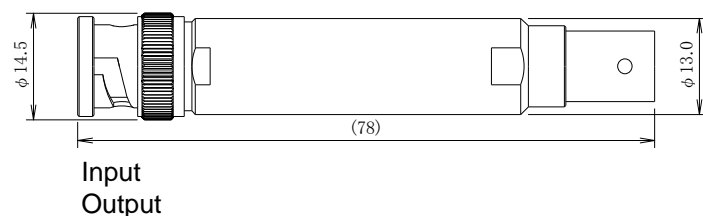

【Step response】

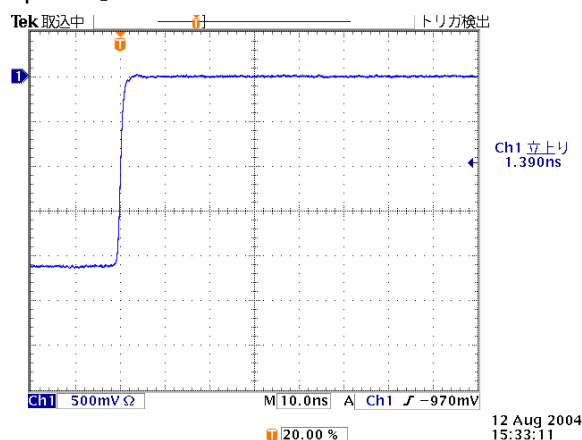

PG506A (Techtronix) $tr \leq 1ns$

7. WARRANTY

Servicing terms

The following terms are applicable to servicing by Noise Laboratory Co., Ltd., (hereafter referred to as the Company) provided to maintain the intended performance of its products.

- Scope**
The following terms shall apply only to products made by the Company.
- Technical servicing fee**
In the event of a failure of a product within the warranty period (see warranty section), the Company will repair a product without charge. After the warranty expires, repairs will be billed at a nominal cost.
- Ownership of defective parts**
Any defective part exchanged under the Company's servicing belongs to it.
- Limited liability**
In the event that damages resulting from servicing by the Company are intentional or caused by negligence, the Company will pay the cost but at the purchase value of the relevant product maximum. But, notwithstanding the foregoing, the Company shall not be responsible for any incidental or consequential damages of any nature, including without limitation thereof loss of would-be profit or compensation demanded from a third party
- Refusal to offer servicing**
The company may not accept a repair order in the following cases:

- More than 5 years have passed since the product discontinued
- More than 8 years have passed after delivery
- Required component for servicing already discontinued and no alternative is available.
- Product changed, repaired or remodeled without obtaining a prior permission from the Company.
- Product severely damaged to the extent it has lost its original form

Limited warranty

The company warrants its products to be free from defects in materials and workmanship under normal use and service for a period of one year from date of delivery. In the event of failure of a product covered by this warranty, the Company will repair the product or may, at its option, replace it in lieu of repair without charge.

Notwithstanding the foregoing, the Company shall not be responsible for any incidental or consequential damages of any nature, including without limitation thereof loss of would-be profit or compensation demanded from a third party. This warranty is valid only in Japan.

- Scope**
This warranty shall only apply to products made by the Company.
- Period**
One year from date of delivery. The warranty may be valid in 6 months after servicing if the same failure on the same component has repeated.
- Exclusions**
The followings are exclusions from this warranty:
 - Consumable parts (including HV relay)
 - Failure caused by misuse, neglect, accident or abnormal conditions of operation
 - Failure caused by remodeling on the user side without prior permission from the Company
 - Failure caused by servicing by unauthorized personnel by the Company
 - Failure due to force majeure including but not limited to, acts of God, fire, war, riot, rebellion and others
 - Failure due to shock or drop in or after transit
 - Failure due to operation in environment being out of ambient specifications.
 - A unit shipped to overseas.

8. MAINTENANCE

- When repair, maintenance or internal adjustment of the unit is required, a qualified service engineer takes charge of such work.
- Maintenance on the user side is restricted to the outside cleaning and functional check of the unit.
- When cleaning the unit, turn off the switch of this unit and the connected equipment and disconnect the plug socket beforehand.
- Avoid using chemicals for cleaning. Otherwise, the coating of the unit may peel off or the sight glass may be broken.
- Do not open the cover of the unit.

9. SUPPORT NETWORK

- If a symptom which seems a trouble is found, inform the model name and serial number of the product together with the symptom to Noise Laboratory or your nearest sales agent of Noise Laboratory.
- When the product is returned to Noise Laboratory, write the state of the trouble, contents of your request, model name and serial number in a repair order, and pack the product and repair order sheet in the former package of equivalent suitable for transit and send them back.

For repair and other services, contact:

International Dept.
 Noise Laboratory Co., Ltd.
 1-4-4 Chiyoda, Chuo-ku, Sagami-hara, Kanagawa
 252-0237, Japan
 Tel: +81 (0)42-712-2051
 Fax: +81 (0)42-712-2050

10. APPLICATION FORM

We apply for buying INSTRUCTION MANUAL.

Model: 00-00007A

Applicant's address:

Company name:

Section:

Name of person in charge:

TEL:

FAX:

Cut off this page "APPLICATION FORM FOR BUYING INSTRUCTION MANUAL" from this booklet and keep it for future use with care.

When an INSTRUCTION MANUAL is required, fill out the above Application Form and mail or fax it to NOISE LABORATORY CO., LTD. or our sales agent.