

INSTRUCTION MANUAL

Clamp Calibration Jig
15-00010A

Noise Laboratory Co., Ltd.
Version 1.01
AEH00163-001-0B

Contents

1. Important Safety Precautions.....	1
2. Introduction.....	1
3. Basic Safety Precaution.....	1
4. Appearance and Description.....	3
5. Usage Procedure.....	3
6. Calibration Procedure.....	4
7. Specifications.....	4
8. Warranty.....	5
9. Maintenance.....	6
10. Noise Laboratory Support Network.....	7
11. Application Form For Instruction Manual.....	7

NOTICE

- The contents of this instruction manual (the "Manual") are subject to change without prior notice.
- No part of the Manual may be reproduced or distributed, in any form or by any means, without the authorization of Noise Laboratory Co., Ltd. (the "Company").
- The contents of the Manual have been thoroughly examined. However, if you find any problems, misprints, or missing information, please feel free to contact our sales agent who you purchased our product from.
- The Company assumes no responsibility for any loss or damage resulting from improper usage, failure to follow the Manual, or any repair or modifications of this product undertaken by a third party other than the Company or the agent authorized by the Company.
- The Company assumes no responsibility for any loss or damage resulting from remodeling or conversion solely undertaken by the user.
- Please note that the Company cannot be held responsible for any consequences arising from the use of this product.

1. Important Safety Precautions

Important points for the safe use of this unit are provided below. Be sure to carefully read this information before use.

1. Do not use this unit in areas where open flames are prohibited or areas having an explosive atmosphere. Electrical discharges can occur during use, which can cause these atmospheres to ignite.
2. Do not allow people with pacemakers or other electronic medical devices to operate this unit and to enter the testing area while this unit is operating.
3. The section "Basic Safety Precautions" contains important safety recommendations, and so be sure to read the section carefully before making the testing environment settings, connections, and starting testing.

2. Introduction

Thank you for purchasing the 15-00010A Clamp Calibration Jig. This unit is a transducer plate for coupling clamps that is compliant with the IEC 61000-4-4 Ed. 3 (2012) standard. Before using this unit, be sure to carefully read this User Guide and use this information to fully utilize the unit's capabilities.

- This User Guide was written to enable operators who can follow the operating procedures and safety precautions to safely operate the 15-00010A and fully utilize its capabilities.
- Store this User Guide in a location that is always easily accessible when operating the 15-00010A.

3. Basic Safety Precautions

1. Safety Warning Signs and Their Meanings

⚠ WARNING 警告 Indicates **Warning**.

Failure to follow this safety information can lead to a **potentially hazardous situation** resulting in **death** or **serious injury**.

⚠ CAUTION 注意 Indicates **Caution**.

Failure to follow this safety information can lead to a **potentially hazardous situation** resulting in a **minor injury** or **moderate damage**.

2. Basic Safety Precautions

⚠ WARNING 警告

1. Do not use this unit in areas where open flames are prohibited or areas having an explosive atmosphere. Electrical discharges can occur during use, which can cause these atmospheres to ignite. (Precaution regarding personal safety and environment)
2. Do not allow people with pacemakers or other electronic medical devices to operate this unit and to enter the testing area while this unit is operating. Failure to observe this can result in malfunctions in the electronic medical device and endanger personal safety. (Precaution regarding personal safety and operation)
3. Noise Laboratory and our affiliated dealers are not liable for any injuries or equipment damage due to improper operation of this unit or for any resulting incidental damages. (Precaution regarding personal safety, operation, environment, and connection)
4. When operating this unit, do not leave the equipment unmonitored. Before leaving this unit, be sure to press the STOP button on the testing equipment to end the testing process. If you fail to observe this, you could endanger people in the surrounding area and testing equipments. (Precaution regarding personal safety, operation, and environment)

⚠ CAUTION 注意

5. Do not use or store in environments with extremely hot or cold temperatures. If you cannot maintain a suitable operating environment (temperature: 15°C to 35°C, humidity: 25% to 75%), the unit can be damaged and result in impaired performance. (Precaution regarding environment)
6. In the event that condensation forms, be sure that the unit is fully dried before starting operation. Failure to observe this can damage the unit and result in impaired performance. (Precaution regarding environment)
7. Avoid using the unit in locations with high humidity or exposed to large amounts of dust. Failure to observe this can damage the unit and result in impaired performance. (Precaution regarding environment)
8. Any required repairs, maintenance, and internal adjustment for this unit must be performed only by service engineers authorized by Noise Laboratory. Failure to observe this can result in impaired performance.
9. Do not wipe the unit with thinner, alcohol, or other solvents. If the unit is dirty, wipe with a cloth dipped in neutral detergent after it is fully wrung out. Wiping with a solvent can damage the unit

surface.

4. Appearance and Description

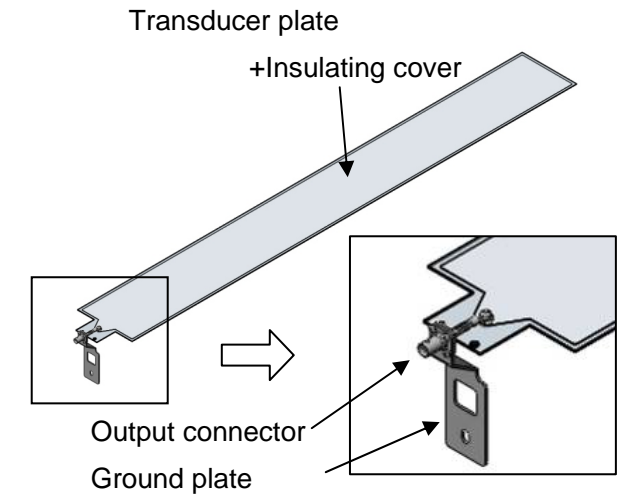

CAUTION!

The output connector is for dedicated high-voltage connectors only. Use the coaxial cable supplied with the coupling clamp 15-00009A or 50Ω attenuator AT-810.

5. Usage Procedure

Insert this jig into the connection plate of the coupling clamp 15-00009A.

15-00009A connection plate

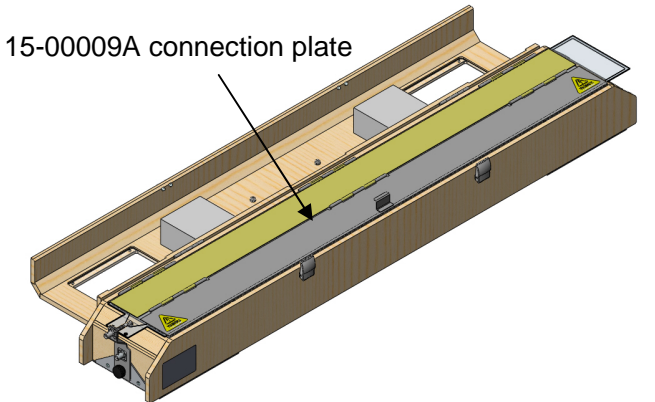

The ground (GND) plate of this unit is connected to the ground plate of the coupling clamp 15-00009A.

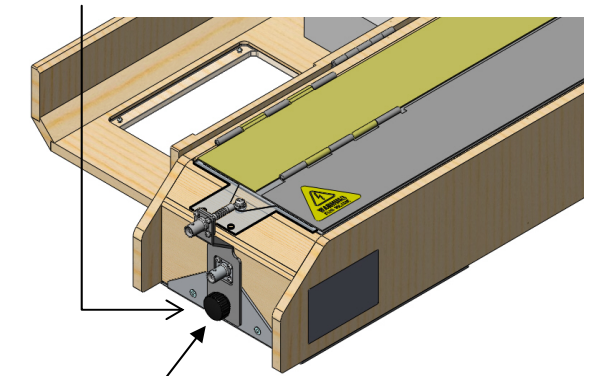

Locked by the GND terminal

6. Calibration Procedure

The calibration method below is based on the IEC 61000-4-4 Ed. 3 (2012) standard and is the standard Noise Laboratory calibration method.

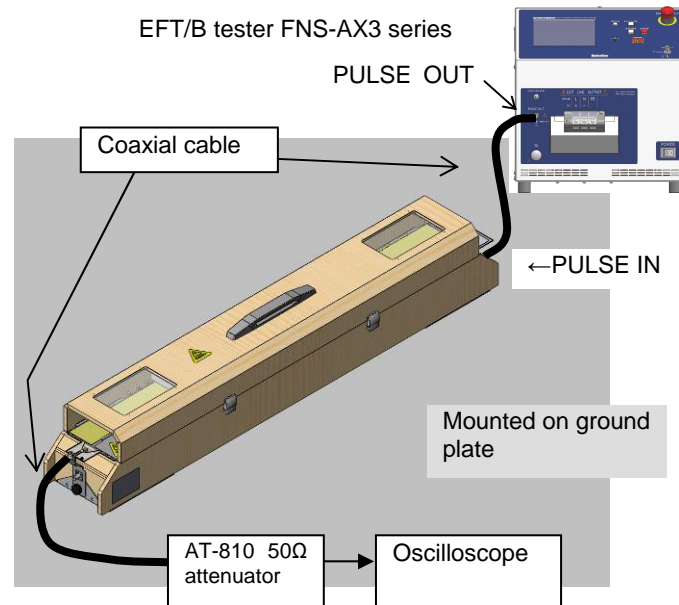

From PULSE OUT terminal of the tester, output a pulse with 2 kV setting value, and evaluate the waveform applied to the clamp calibration unit. Waveform evaluation: One pulse

- Rise time: 5 ± 1.5 ns
- Pulse width: 50 ± 15 ns
- Peak voltage: $1000 \text{ V} \pm 200 \text{ V}$

Additional Note:
In the coupling clamp calibration method (Figure 8) in the IEC 61000-4-4 Ed. 3 standard, a 50Ω terminator is connected near the transducer plate output.
In the standard Noise Laboratory method, for convenience, a 50Ω terminator is connected at a point extended by 1 meter from the transducer plate output by a coaxial cable.
The extension by the coaxial cable uses 50Ω impedance matching so that it is equivalent to terminating near the output, and this has been confirmed to pose no problems in waveform verification.

7. Specifications

Item	Specifications/Performance
Transducer plate dimensions	Length: 1050 ± 5 mm Width: 120 ± 1 mm
Maximum dimensions	(D)1130×(W)130×(H)109 mm
Operating temperature range	15°C to 35°C
Operating humidity range	25% to 75%
Weight	350 g

8. Warranty

Services

The following terms are applicable to the services provided by the Company to maintain and repair the Unit.

1. **Scope**
The Unit and accessories and options provided by the Company are covered under this section.
2. **Technical Service Fee**
Any repairs provided by the Company during the warranty period will be free of charge in accordance with the Limited Warranty. After expiration of the warranty period, actual cost for the repair will be charged to the user.
3. **Ownership of Defective Parts**
All the defective parts replaced during the warranty period become the property of the Company. For paid repairs, they also become the property of the Company unless otherwise directed by the user.
4. **Maximum Compensation**
In the event the user incurs damage due to malfunction of the Unit arising solely from the negligence and/or improper repair on the part of the Company, the Company will compensate for the damage. The maximum compensation amount shall be limited to the amount paid by the user at the time of purchase of the Unit. In no event, shall the company be liable or in any way responsible for incidental or consequential damages such as loss of profit or third party's claims to the user.
5. **Wrong Parts, Missing Parts and Damage**
The company shall not be liable for loss of profit, business interruption, other incidental damage, special loss, punitive damage or third party's claims to the user directly or indirectly arising from suspension of testing activities due to wrong parts, missing parts, or damage of the Unit.

6. Service Refusal

The company may not accept a repair order in the following cases:

- More than 5 years have passed since the product discontinued
- More than 8 years have passed after delivery
- Required component for servicing already discontinued and no alternative is available.
- Product changed, repaired or remodeled without obtaining a prior permission from the Company.
- Product severely damaged to the extent it has lost its original form

Limited Warranty

In the event of failure during the warranty period, the Unit will be repaired or replaced free of charge. Decision of the repair method shall be left at the discretion of the Company. This limited warranty is applicable in Japan only.

1. **Scope**
This warranty is applicable only to the Unit and its accessories.
2. **Warranty Period**
One year from the date of delivery.

For a location once repaired, the warranty period for same parts / same problems is 6 months from the time of repair completion.

3. **Exceptions**
Regardless of the above, following will be excluded from the warranty.
 - ◇ Consumable parts replacement, including High Voltage Relay (if used)
 - ◇ Failure caused by negligence, or damage to the Unit.
 - ◇ Failure due to modifications made without the Company's authorization.
 - ◇ Failure due to repairs made by personnel not authorized by the Company.
 - ◇ Failure directly or indirectly arising from force majeure including but not limited to, acts of god, fire, war, rebellion and others.
 - ◇ Failure due to shipping, vibration, falling, or impact shock after delivery
 - ◇ Failures due to use of the Unit under the improper environment.
 - ◇ When the Unit is taken out of the country.

9. Maintenance

1. When repair, maintenance or internal adjustment of the Unit is required, a qualified service engineer takes charge of such work.
2. Maintenance on the user side is restricted to the outside cleaning and functional check of the Unit.
3. When checking or replacing the fuse, turn off the switch of the Unit and disconnect the plug socket beforehand.
4. When cleaning the Unit, turn off the switch of the Unit and the connected equipment and disconnect the plug socket beforehand.
5. Avoid using chemicals for cleaning. Otherwise, the coating of the Unit may peel off or the sight glass may be broken.
6. Do not open the cover of the Unit and Probe.

10. Noise Laboratory Support Network

- If a symptom which seems a trouble is found, inform the model name and serial number of the product together with the symptom to Noise Laboratory or your nearest sales agent of Noise Laboratory.
- When the product is returned to Noise Laboratory, write the state of the trouble, contents of your request, model name and serial number in a repair order, and pack the product and repair order sheet in the former package of equivalent suitable for transit and send them back.

NOISE LABORATORY CO., LTD.
SALES DEPT.

TEL: +81-42-712-2051
FAX: +81-42-712-2050

E-mail: sales@noiseken.com
http://www.noiseken.com

9. Maintenance

----- CutLine -----

11. Application Form For Instruction Manual

We place an order for an instruction manual.

Model:
Serial No.:

Applicant: _____
Company name: _____
Address: _____

Department: _____
Person in charge: _____
Tel No.: _____
Fax No.: _____

Cut off this page "APPLICATION FORM FOR INSTRUCTION MANUAL" from this volume and keep it for future use with care.

When an INSTRUCTION MANUAL is required, fill in the above Application Form and mail or fax it to the following sales department of our company.

To: NOISE LABORATORY CO., LTD.
1-4-4 Chiyoda, Chuo-Ku, Sagamiara City,
Kanagawa Pref. 252-0237 Japan
Tel: +81-42-712-2051 Fax: +81-42-712-2050