



INSTRUCTION MANUAL

LIGHTNING SURGE SIMULATOR

MODEL **LSS-6330-A20**

NOISE LABORATORY CO., LTD.

The 1.02 edition
AEE00663-00E-0

NOTICE

- The contents of this instruction manual (the “Manual”) are subject to change without prior notice.
- No part of the Manual may be reproduced or distributed, in any form or by any means, without the authorization of Noise Laboratory Co., Ltd. (the “Company”).
- The contents of the Manual have been thoroughly examined. However, if you find any problems, misprints, or missing information, please feel free to contact our sales agent who you purchased our product from.
- The Company assumes no responsibility for any loss or damage resulting from improper usage, failure to follow the Manual, or any repair or modifications of this product undertaken by a third party other than the Company or the agent authorized by the Company.
- The Company assumes no responsibility for any loss or damage resulting from remodeling or conversion solely undertaken by the user.
- Please note that the Company cannot be held responsible for any consequences arising from the use of this product.

1. IMPORTANT SAFETY PRECAUTIONS

The following instructions are very important for safe handling of the lightning surge simulator LSS-6330-A20 (hereinafter "the Unit"). They must be kept strictly to prevent users of the Unit from receiving harm or damage through using the Unit. Read them carefully before use.

- **Only well-trained EMC technicians (electric technicians) are allowed to use the Unit.**

The Unit may cause a fatal wound. Carefully handle it. And it may radiate electromagnetic noise which exceeds the regulation value. Take applicable countermeasures such as faraday cage, shield room, etc. as the need arises.

- **The Unit should be used only for EMC testing described in this manual.**

Using it for other purposes may result in a fatal or serious accident.

- **A person who has a pacemaker on should not operate the Unit and also should not enter the area where it is operating.**

It may result in a fatal or serious accident.

- **The Unit cannot be used in an explosive area, fire prohibited area, etc.**

Use of the Unit in such an area is liable to cause combustion or ignition.

A number of safety recommendations are listed in the later chapter "BASIC SAFETY PRECAUTIONS". Be sure to read them before test environment settings, connecting relating equipment and testing.

2. CHECK PACKAGE CONTENTS

Before using the instrument, check whether the included accessories are complete according to the following list.

A



B



C

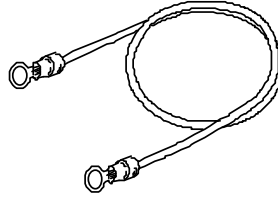

D

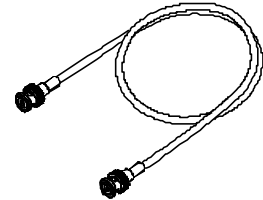

E

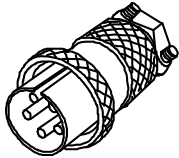

F

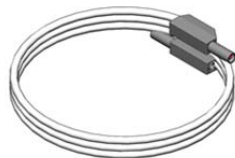

G

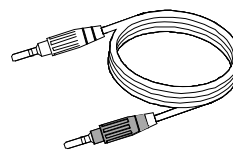

H



I



J



A : AC cable-----	1
B : Line output cable-----	3
C : FG cable (2m) (MODEL : 05-00070A M6—M6) -----	1
D : Coaxial cable for monitoring (1m) (MODEL : 02-00128A BNC—BNC) -----	1
E : Interlock connector -----	1
F : Surge output confirmation cable set (Plug-round crimp terminal cable 0.5m x 2, plug-plug cable 1m x 1)-----	1 set
G : Line output confirmation cable set (Plug-round crimp terminal cable 0.5m x 2, plug-plug cable 1m x 1)-----	1 set
H : Line input cable: 1 red, 1black, 1 green/yellow-----	1 set
I : Instruction manual -----	1
J : Accessory bag -----	1

3. APPLICATION FORM FOR INSTRUCTION MANUAL

We place an order for an instruction manual.

Model: LSS-6330-A20

Serial No.: _____

Applicant:

Company name: _____

Address: _____

Department: _____

Person in charge: _____

Tel No.: _____

Fax No. _____

Cut off this page “APPLICATION FORM FOR INSTRUCTION MANUAL” from this volume and keep it for future use with care.

When an INSTRUCTION MANUAL is required, fill in the above Application Form and mail or fax it to the following sales department of our company.

To: Noise Laboratory Co., Ltd.

1-4-4 Chiyoda, Chuo-ku, Sagamihara City,

Kanagawa Pref., 252-0237 Japan

Tel: +81-(0)42-712-2051

Fax: +81-(0)42-712-2050

Cut
line

4. PREFACE

We thank you very much for your purchase of our Lightning Surge Simulator LSS-6330-A20 (hereinafter “the Unit”). This instruction manual (“the Manual”) contains how to use the Unit and other important information. In order to obtain the highest performance from the Unit, thoroughly understand the contents of the Manual and use as ready reference for operation.

-
-
- The Manual was prepared so that any person who can observe the prescribed instruction method and operating precautions may safely handle and fully utilize the Unit.
 - Keep the Manual by your side or other proper location so that it may be readily available when using the Unit.
-
-

4-1. Feature

Conforming to IEC61000-4-5 (Edition 3.0 / 2014)

- Generating combination wave surge of 1.2/50 μ s and 10/700 μ s prescribed by IEC 61000-4-5 (Edition 3 / 2014).
Combination waves mean output of 1.2/50 μ s or 10/700 μ s voltage surge waveform with the surge output unit opened (load: more than 10k Ω) and output of 8/20 μ s or 5/320 μ s current surge waveform with the output unit short-circuited.
- Testing high voltage and great electric current (voltage surge: 6.7kV, current surge: 3350A). The surge generating circuit adopts a floating output system recommended by IEC 61000-4-5 (Edition 3 / 2014).
- Capable to conduct surge injection test to power supply lines with the CDN (Coupling and Decoupling Network) for EUT which is equipped as standard equipment. The AC/DC line injection part adopts a circuit system conforming to IEC 61000-4-5 (Edition 3 / 2014).
- Generating 0.5 μ s -100kHz ring wave surge prescribed by IEC61000-4-12. Testing maximum 6.6kV high voltage surge.

User-friendly LCD Control Panel

- The operation panel adopts a color LCD touch panel for pursuing high visibility.
- Capable of various kinds of setup with simple touch panel.
- Employs push buttons for handling safety-related operation such as START/STOP.

Various Functions Broaden Horizons of Test

- Preset test conditions which are prescribed on the standard in the “standard test” mode.
- Capable to set test conditions as you like in the “manual test” mode.
- “Sweep” function enable automatic step-by-step change of test parameters.
- Capable to save your test conditions.
- Remote control is available with optical communication (optional).

5. CONTENTS

1. IMPORTANT SAFETY PRECAUTIONS.....	1
2. CHECK PACKAGE CONTENTS.....	2
3. APPLICATION FORM FOR INSTRUCTION MANUAL.....	3
4. PREFACE.....	5
4-1.Feature.....	5
5. CONTENTS.....	6
6. BASIC SAFETY PRECAUTIONS.....	9
6 - 1.Symbols of Hazard.....	9
6-2.Symbols of Instruction, Warning and Caution.....	9
6-3.Danger.....	11
6-4.Warning.....	11
6-5.Caution.....	13
7. CAUTION ABOUT EXPENDABLE SUPPLIES.....	15
8. INTRODUCTORY NOTES.....	16
8-1.Introductory Notes.....	16
8-2.Terms and Definitions.....	16
8-3.Definition of Surge Waveform.....	17
Voltage Surge Waveform.....	17
Current Surge Waveform.....	17
8-4.Block Diagram.....	18
9. APPEARANCE AND FUNCTION OF EACH PART.....	19
9-1.Appearance of The Main Unit.....	19
9-2.Front Panel.....	20
9-3.Rear Panel.....	22
10.CONNECTION.....	24
10-1.Connecting AC Cord.....	24
10-2.Connection of Optical Communication Cable (Optional).....	25
10-3.Connection for Applying Surge Waveform to EUT Directly.....	25
Connection of Surge Output.....	25
10-4.Connection for Applying Surge Waveform to AC/DC Line.....	26

Connection of AC/DC Line Input	26
Connection of AC/DC Line Output	27
11. OPERATION	28
11—1.Power ON unit	28
11—2.Emergency Stop Button	28
How to cancel emergency stop	28
11—3.Main Menu	29
11—4.Screen Flowchart	30
11—5.Inputting Numbers and Letters (About Ten Key and Character Key)	31
12. STANDARD TEST	32
12—1.Setting Standard Test	32
Discharge Interval	34
12—2.AC LINE Standard	34
12—3.DC LINE Standard	35
12—4.ENCLOSURE Standard	35
12—5.Executing Standard Test	36
13. MANUAL TEST	41
13—1.Setting Manual Test	41
Selecting Output	43
Selecting Synchronization (Phase Angle) / Synchronization	44
Selecting Waveform	45
Selecting Polarity	45
Setting Voltage	46
Setting Discharge Times	47
Setting Interval	47
13—2.Setting AC/DC Injection	48
13—3.Executing Manual Test	52
14. TITLE SAVE / LOAD	56
Save	57
Changing Title	57
Load	58
Delete	58
15. UTILITY	59
Power ON Display	59
Alarm Beep	59
Language	59

EUT LINE Voltage Detection	59
External Trigger.....	60
Interlock Level.....	61
Sequence Method.....	61
Title Operation.....	61
Phase Angle Correction.....	61
EUT FAIL Signal.....	62
16. PHASE ANGLE CORRECTION.....	63
17.PRE CHECK.....	65
18. ERROR MESSAGE.....	67
19.SPECIFICATIONS	68
19—1.General specifiactions.....	68
19—2.Surge Generating Part.....	69
19—3.AC / DC Line Injection Part.....	70
20.OPTIONAL PRODUCT	71
21.WAVEFORM VERIFICATION.....	72
21—1.Preparation.....	72
21—2.Connection.....	72
How to observe at Monitor Terminal.....	72
21—3.Measurement.....	73
21—4.Why PE of Oscilloscope Should Not be Common with Earth of the Unit.....	73
22.WARRANTY.....	74
23.MAINTENANCE.....	76
24.NOISE LABORATORY SUPPORT NETWORK.....	77

6. BASIC SAFETY PRECAUTIONS

- The following items are very important instructions which users must follow to take precautions against possible injury and harm.
- The indications are provided as an explanation of potential danger involved if the safety precautions are not observed correctly.

6 - 1. Symbols of Hazard

- ◆ The following display classifications describe degree, to which injury or harm might occur when the contents of the display are not followed or the Unit or related equipment is operated incorrectly.



DANGER

The contents of this display indicate “the assumption that imminent danger might occur resulting in death or serious injury” if the Unit or related equipment is handled incorrectly.



WARNING

The contents of this display indicate “the assumption that there is a possibility of death or serious injury” if the Unit or related equipment is handled incorrectly.









CAUTION

The contents of this display indicate “the assumption that there is a possibility of harm and the assumption that there is a possibility of physical damage” if the Unit or related equipment is handled incorrectly.



6–2. Symbols of Instruction, Warning and Caution

- ◆ The following display classifications describe details that should be followed.



	Indicates attention (a matter that must be paid attention fully)		
	Indicates prohibition (an action that must not be taken)	 Prohibited	 Do not disassemble
	Indicates a compulsory action (an action that must be taken)	 Compulsory	

	<p>Noticing possibility of an electric shock It indicates that there is possibility of an electric shock.</p>
	<p>Noticing caution, warning and danger It indicates that there is a possibility of harm or physical damage if the Unit is or related equipment is handled incorrectly and that the Manual should be referred.</p>
	<p>It indicates warnings for electric shock etc. and the Manual should be referred.</p>
	<p>Notifying danger of electric shock and the Manual should be referred.</p> <p><u>Warning</u> To reduce the risk of electric shock, do not remove cover.</p>
	<p>Notifying danger of electric shock and the Manual should be referred.</p> <p><u>Caution in handling</u> Noise Laboratory Co., Ltd. is excluded all the liability of any forms of damage, of equipment or humans, caused by user's mishandling during operation.</p>
	<p>Notifying danger of electric shock and the Manual should be referred.</p> <p><u>Caution in handling</u> SOCKET WITH LOCK PUSH AND THEN PULL OUT</p>
	<p>Notifying danger of electric shock and the Manual should be referred.</p> <p><u>Caution in handling</u> Lifting may damage back.</p>

6-3. Danger

 <p>Do not disassemble</p>	<p>Do not take the Unit apart or remodel. Do not open the cover.</p> <p>Imminent danger might occur resulting in death or serious injury. Repair, internal adjustment, and inspection of the Unit should be performed by a qualified service engineer. Ask the Company or its sales agent.</p>
 <p>Prohibited</p>	<p>Do not use the Unit in an explosive are or fire-prohibited area etc.</p> <p>Use of the Unit in such an area is liable to cause combustion or ignition.</p> <hr/> <p>A person who has a pacemaker on should not operate the Unit and also should not enter the area where it is operating.</p> <p>It may result in a fatal or serious accident.</p>

6-4. Warning

	<p>Stop operation if following unusual phenomena should occur.</p> <ul style="list-style-type: none"> ○ Emitting fumes, or smelling. ○ Water or an unusual substance being stuck ○ Being dropped or being damaged ○ AC cable being damaged (e.g. core lines being exposed etc.) <p>Continuing to operate in the above status may result in a fire, electric shock, or injury. If an unusual phenomenon occurs, turn off power supply immediately, pull AC plug out of an outlet, and ask the Company or sales agent repair. As there is potential danger, any user must not repair the product.</p>
 <p>Compulsory</p>	<p>Insulate and protect the test facility against maximum output voltage of the Unit.</p> <p>If the test facility is not so insulated and protected, there is the dangerous possibility of an electric shock, leak or fire.</p>
	<p>Turn off power supply of the Unit when setting or changing connection of related equipment.</p> <p>Failure to follow this notice may cause electric shock, injury, or malfunction.</p>
	<p>Fully pay attention to insulation of surge return route also.</p> <p>The surge generating circuit of the Unit adopts floating system. Since the return route is not connected to the chassis, high voltage may generate on the return route.</p>
	<p>Use the Unit after understanding instructions in the Manual fully.</p> <p>There may be danger causing a fatal or serious wound or emitting over-ristricted-value electromagnetic noise in using the Unit. NOISE LABORATORY and its sales agents shall have no liability against any accident resulting in injury or death, any damage to equipment or any resultant damage thereof, which is caused by abuse or careless handling of this unit.</p>

	<p>Watch equipment while the Unit is operating. If this instruction should not be followed, a third person or equipment related to the test may be exposed to a danger.</p> <p>Supply power within the indicated range (AC100 V~240 V). The misuse may cause an electric shock or a fire. The attached AC cord in the accessory is for AC100~120 V. Prepare a proper 3-line AC cord with a protective earth pin conforming to the local safety standard in using with AC220~240 V power supply.</p> <p>Use proper connectors and cables and connect them securely. Avoid using a damaged connector or cable. The misuse may cause an electric shock or damage of equipment.</p> <p>Insert AC plug securely to the end. Insecure inserting generates heat and gathers dust. It may result in a fire or an electric shock. Avoid using a multiple outlet extension plug for the same reason.</p> <p>Install the Unit on a stable place. If the Unit is installed on an unstable place, human body may be in danger due to drop or overturn of the Unit.</p> <p>Connect the protective earth of AC cord. Using the Unit without connecting it may cause an electric shock.</p> <p>Be sure to insert an isolation transformer between LINE IN of the Unit and AC LINE power supply for AC LINE Injection test. If AC LINE power is supplied to the Unit directly, a circuit breaker installed on the power supply may function due to leak current from the Unit.</p>
 Prohibited	<p>Do not use the Unit for any other purpose than Surge test. The misuse may result in an electric shock, an injury, or damage of equipment.</p> <p>Do not put any substance into the Unit or its connectors. If some metal or flammable things are put into the Unit through a connector or a vent, it may result in a fire or an electric shock.</p> <p>Do not use the attached AC cord for any other purpose. The misuse may result in a fire or an electric shock.</p> <p>Do not install the Unit on the spot where quick operation of power key or STOP key is difficult. If the simulator is set up on such a spot, difficulty in taking action in emergency may result in a fire or an electric shock.</p>

 Prohibited	<p>Do not damage AC cord.</p> <p>A damaged AC cord may cause a fire or an electric shock. For HV cable, be sure to take notice following points.</p> <ul style="list-style-type: none"> ○ Do not work it. ○ Do not bend it forcibly. ○ Do not twist it. ○ Do not pull it. ○ Do not move it close to heat. <p>Do not put heavy things on it.</p>
---	---

6-5. Caution

 Compulsory	<p>Take actions against emission of electromagnetic waves.</p> <p>When a test is performed using the Unit, a great amount of electromagnetic waves are emitted according to the type of EUT, sometimes adversely affecting the neighboring electronic equipment and radio communication apparatus. The user is required to provide a Faraday gage, shield room, shielding cable, etc. as necessary.</p>
	<p>Do not connect an AC/DC power line to SURGE OUT terminal directly.</p> <p>Connecting the power line directly damages the internal unit.</p>
	<p>If dewing occurs, fully dry up the Unit before using it.</p> <p>Dews may cause an electric shock, a trouble, a fire.</p>
	<p>Use the Unit in proper environment.</p> <p>Operating temperature range is 15~35°C. Operating humidity range is 25~75%. If these precautions are not followed, the unit may be broken or the prescribed performance may not be warranted.</p>
	<p>Clean up the AC plug periodically.</p> <p>If dust gets damp between the AC plug and outlet, insulation capability deteriorates. It may result in a fire. Pull the AC plug out from an outlet periodically and wipe it with a dry cloth.</p>
	<p>When the body is dirty, wipe the body with a dry cloth.</p> <p>Do not wipe the Unit and Probe with thinner, alcohol or other solvent. When the body is very dirty, soak a cloth into neutral detergent, squeeze out the detergent from the cloth and wipe the body with the cloth.</p>
	<p>Make hazardous labels always noticeable.</p> <p>When the caution or warning label is peeled off, missing or dirty, attach a new one for securing safety. When the caution or warning label is missing, ask the sales department or maintenance section of our company to send a new label.</p>

 Prohibited	<p>Do not work alone when moving the installation.</p> <p>This unit is heavy. When moving the installation site, take safety measures by multiple people.</p>
	<p>Do not install the Unit on following places.</p> <p>Setting up the Unit on wrong places as follows may result in a fire, an electric shock, or an injury.</p> <ul style="list-style-type: none"> ○ A very humid or dusty place ○ A hot place, e.g. a place exposed to direct rays of the sun, a place close to a heater. ○ A place easy to bedew, e.g. a place close to a window.
	<p>Do not block a vent or do not use the Unit in a place poorly ventilated.</p> <p>If a vent is blocked, the internal heat is close. It may cause a fire. For ventilation, be sure to take notice following points.</p> <ul style="list-style-type: none"> ○ Do not lay the Unit on its back, sideways, or upside down. ○ Do not put the Unit into a small, poorly ventilated place. ○ Keep the Unit at least 10cm away from a wall or some substance.
	<p>Do not handle the AC plug with your hand wet.</p> <p>The misuse may result in an electric shock or trouble.</p>
	<p>Do not operate LCD panel with something sharp or pointed.</p> <p>The misuse may result in damage of the touch panel.</p>
	<p>Do not drop or shock the Unit excessively.</p> <p>The misuse may cause trouble or damage.</p>
	<p>Do not bump or rub the Unit against something hard.</p> <p>The misuse may damage a surface of the Unit.</p>
	<p>Do not put any heavy thing or sit on the Unit.</p> <p>The misuse may result in a dent on the body or damage of internal components.</p>

7. CAUTION ABOUT EXPENDABLE SUPPLIES

● About a high voltage relay inside

- A high voltage relay used inside is an expendable component.
- The lifetime of it is dependent on using conditions and environment.
- If a symptom which seems to be caused by an exhausted high voltage relay, e.g. unstable current value, unstable repetition cycle or so on, is found, contact Noise Laboratory or your closest sales agent of Noise Laboratory. Repair by a user is impossible.

● Fuse

- The instrument contains fuses.
The fuse holder is located in the AC inlet and the fuse can be replaceable is user.
Please replace with a fuse of the following type.

Rated voltage 250 V / Rated current 3.15A Slo-Blo type
Recommended Fuse : Littelfuse 2153.15MXP
Quantity : 2

- If unable to obtain the correct fuse, please contact your sales agent or the Noise Laboratory Customer Service Center.

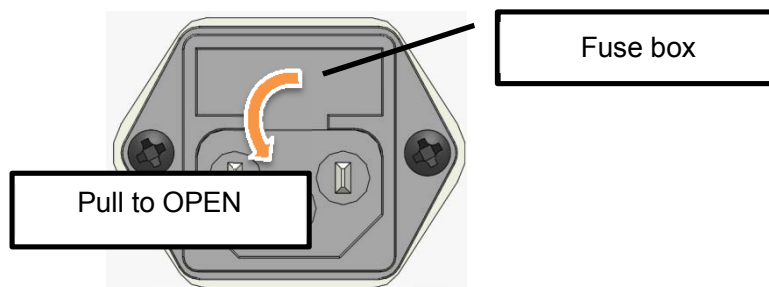









Fig 7-1. Fuse Box

In the event of failure in normal usage, repair shall be performed under the condition of the warranty rule. However, NOISE LABORATORY and its sales agents shall not be liable for any accident resulting in damage of DUT or peripheral equipment caused by deterioration of performance of expendable parts or any other external factors.

8. INTRODUCTORY NOTES

8—1. Introductory Notes

The meaning of following symbols is as follows.

	Operate the touch panel.
	Additional explanation.
	Indicating other parts to be referred in the Manual.
	Indicating restriction of setting up.
	Indicating items to be confirmed before usage.
	Indicating text on the panel of the Unit.
	Indicating text on the LCD of the Unit.

8—2. Terms and Definitions

The terms and their definitions are shown as follows.

Term	Definition
Surge	Transient wave of electrical voltage, current, or power, propagating along a line or a circuit. It is a single waveform characterized by a rapid increase followed by a slower decrease. The phenomenon occurs sometimes by lightening, sometimes by transient response of switching of a circuit.
Voltage surge	Surge which waveform is formed in as voltage. With this simulator, this waveform is defined as a voltage waveform which is observed when some load (EUT or DUT) is connected to the output including when the output is open.
Current surge	Surge which waveform is formed in as voltage. With this simulator, this waveform is defined as a current waveform which is observed when some load (EUT or DUT) is connected to the output including when the output is short-circuited.
Front time	Parameter defining rise time of surge waveform. Each of voltage surge and current surge has its own definition of front time.
Duration	Time interval between the instant at which the rise time to 50% of surge peakvalue, and then falls to 50% of its peak value
Output impedance	Effective output impedance of the surge generating circuit. The following formula is used to acquire it. (Peak voltage value in open) / (Peak current value in short-circuited)
DUT	Device Under Test. A device to be tested by test equipment.
EUT	Equipment Under Test. Equipment to be tested by test equipment.

8-3. Definition of Surge Waveform

Voltage Surge Waveform

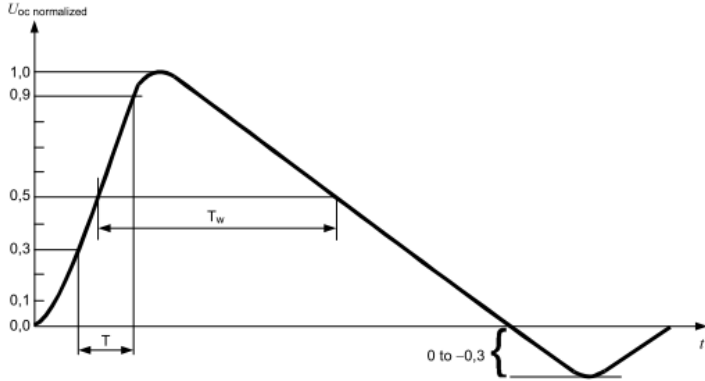

Fig 8-1 Voltage surge waveform

Front time (T1): 1.67 times of the interval of time between the instants when the voltage value increases to 30% and 90% of the peak value.

Duration (T2): Time interval between the instant at which the surge voltage rises to 0.5 of its peak value, and then falls to 0.5 of its peak value

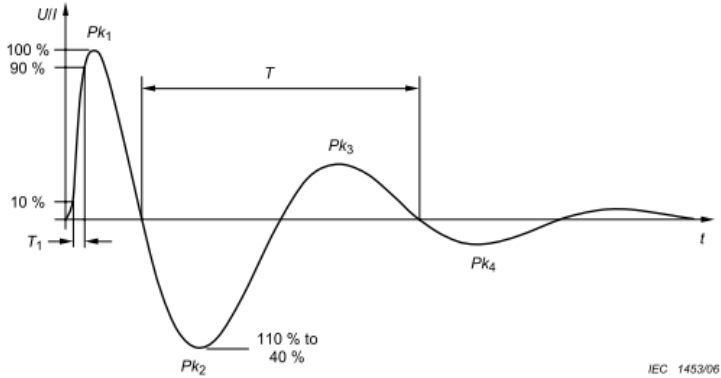

Fig 8-2 RINGWAVE Voltage waveform

Front time (T1): : Time interval between the instants when the voltage value increases to 10% and 90% of the peak value

Oscillation period (T) : The reciprocal of the time between the zero-cross point after the first peak and the zero-cross after the third peak.

Current Surge Waveform

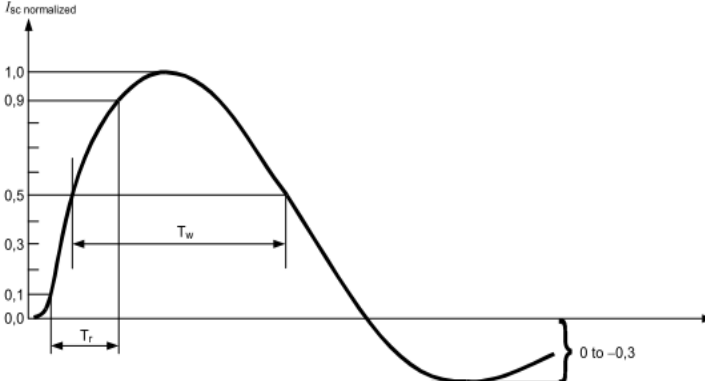
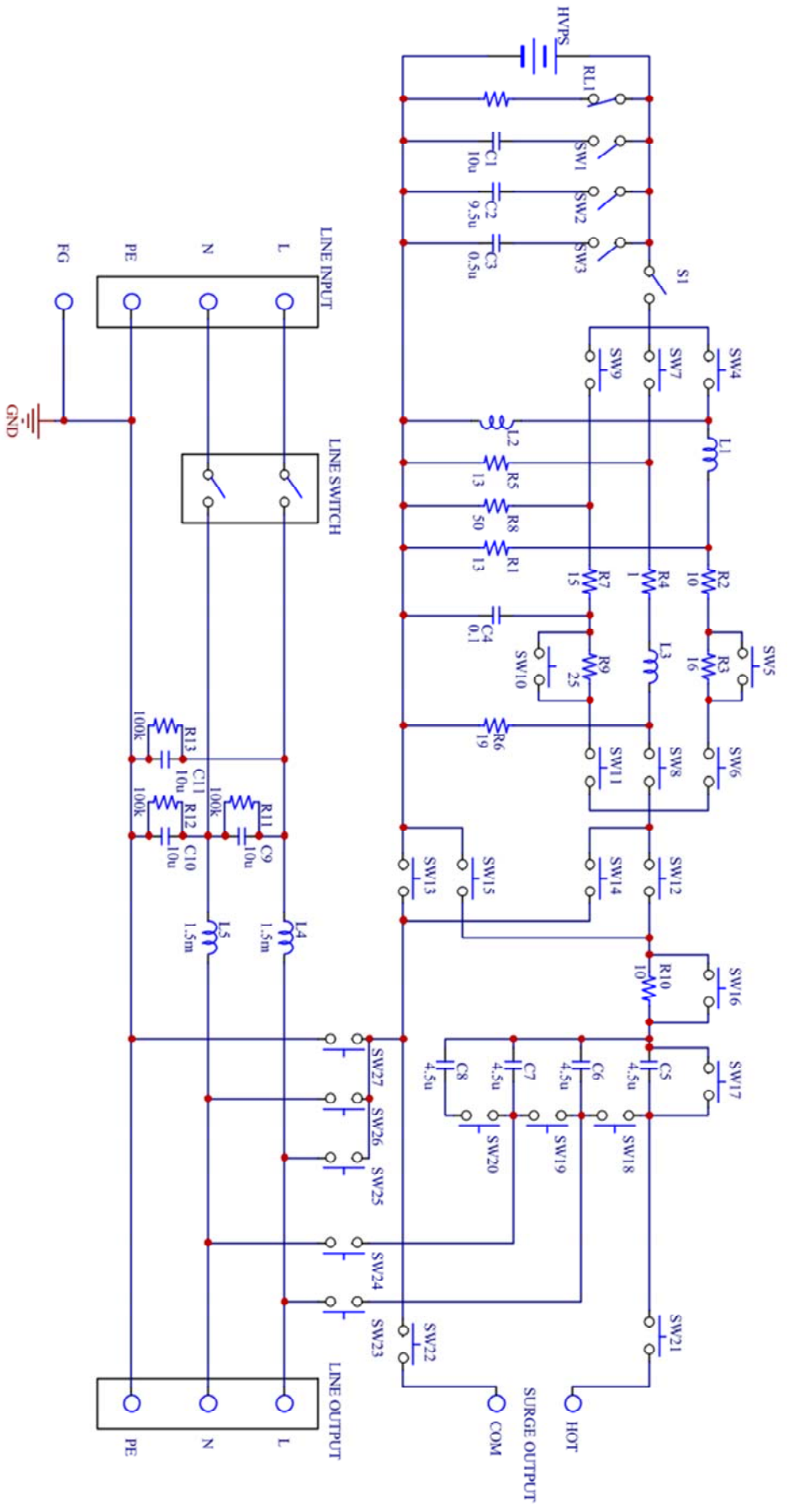

Fig 8-3 Current surge waveform

Front time (T1): 1.25 times of the interval of time between the instants when the current value increases to 10% and 90% of the peak value.

Duration (T2): virtual parameter defined as the time interval between the instant at which the surge current rises to 0.5 of its peak value, and then falls to 0.5 of its peak value (Tw) for 5/320uS waveform, and multiplied by 1.18 for 8/20uS waveform

8-4. Block Diagram



HVPS : High voltage power supply , RL1 : Elimination relay
 S1 : Surge Switch , C1~C3 : Surge Capacitor

Coupling capacitor : C5~C8 , Coupling resistor : R10
 Decoupling inductance : L4,L5 , Decoupling capacitor : C9~C11

SW operation
 Turn ON in 1.2/50us surge : SW2,SW7,SW8
 Turn ON in 10/700us surge : SW1,SW2,SW9,SW11,SW16,SW17
 Turn ON in RINGwave surge : SW3,SW4,SW6
 (SW5 : RING124 in ON)

Turn ON in positive surge polarity : SW12,SW13
 Turn ON in negative surge polarity : SW14,SW15
 Turn ON in Coupling network 18uF : SW16,SW18,SW19,SW20
 Turn ON in Coupling network 9uF+10Ω : SW18,SW20

9. APPEARANCE AND FUNCTION OF EACH PART

9-1. Appearance of The Main Unit

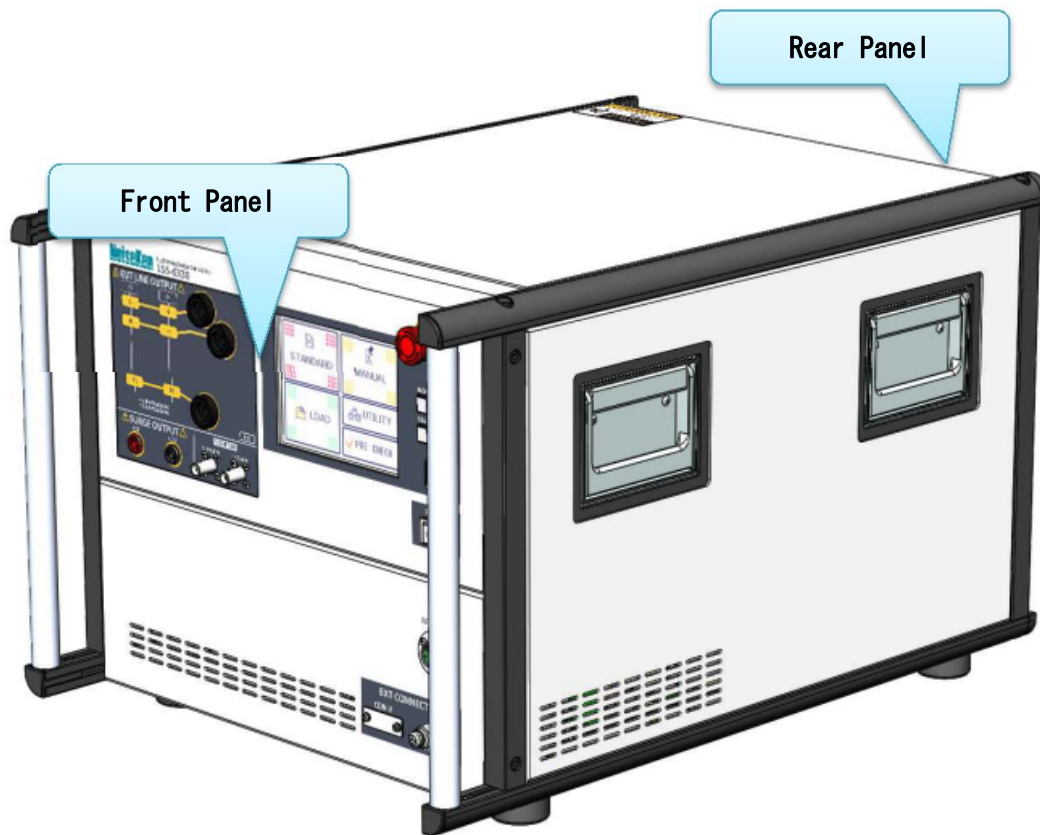

9-2. Front Panel

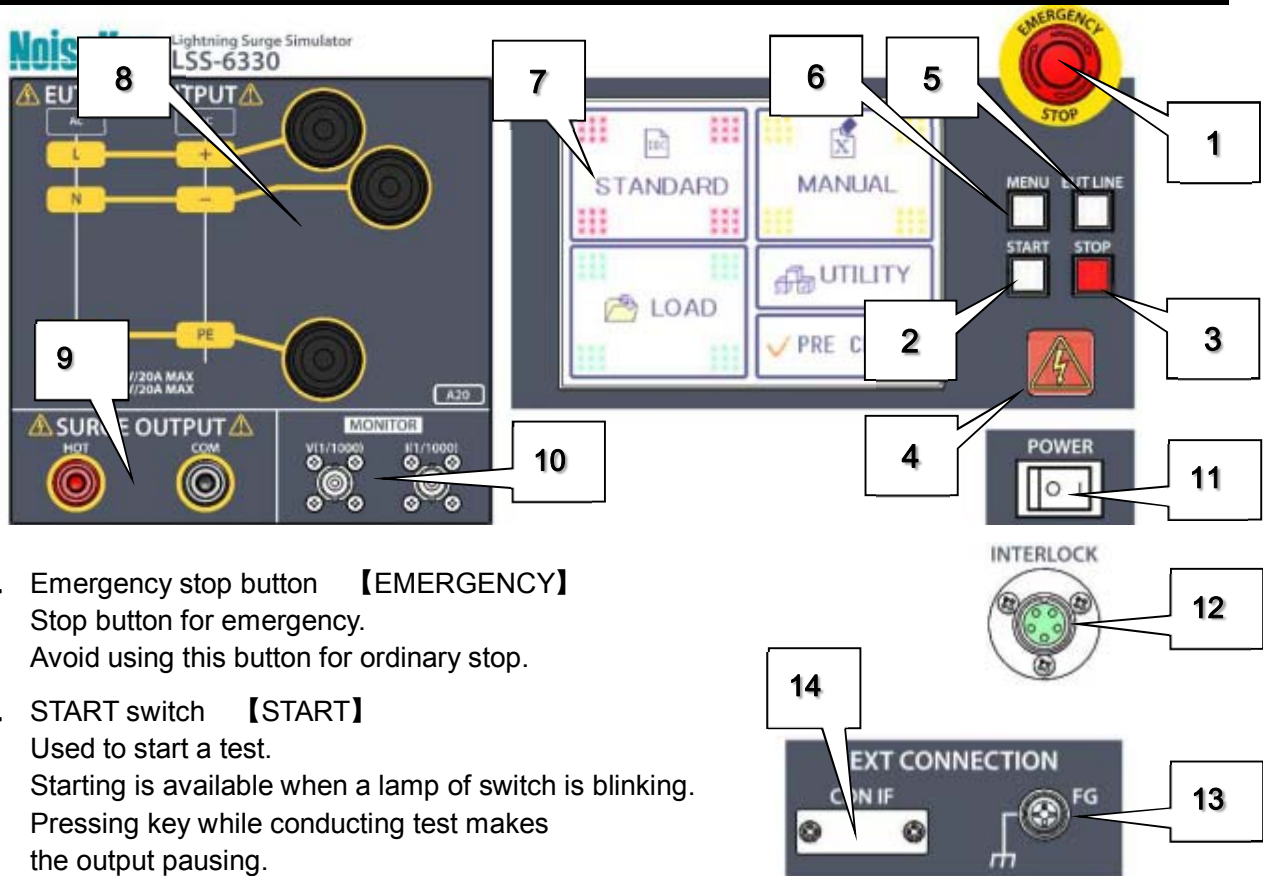

1. Emergency stop button 【EMERGENCY】
Stop button for emergency.
Avoid using this button for ordinary stop.
2. START switch 【START】
Used to start a test.
Starting is available when a lamp of switch is blinking.
Pressing key while conducting test makes the output pausing.
3. STOP switch 【STOP】
Used to stop a test.
4. Warning lamp
Blinking while a test is being performed.



As high voltage are generated while this lamp is blinking, carefully handle the Unit.

5. EUT LINE switch 【EUT LINE】
Used to turn ON/OFF EUT LINE which is used for power line test.



The EUT LINE key is designed to turn ON/OFF a usual EUT, but if the EUT is an extremely inductive load, use the power switch of the EUT instead of the EUT LINE key.



Voltage detection at AC or DC line input when turning on the line switch.
Minimum detectable voltage: AC 90V, DC 10V.

6. MENU switch 【MENU】
Makes the LCD touch panel display 'MENU' screen. This operation is unavailable when testing.
7. LCD touch panel
Selects operation mode and sets test conditions.

8. EUT line output terminals 【EUT LINE OUTPUT】

EUT line output terminal of L/N/PE. The EUT shall be connected to EUT LINE OUTPUT ports by using the supplied line output cables.

The EUT LINE OUTPUT and the accessory cables adopt Snap-in lock system connector by Staubli Electrical Connectors AG.



This Snap-in system automatically locks-in (with a click sound) cable plug (or a socket) onto panel socket (or a plug) to prevent unwanted disconnection. To unlock, push 'LINE OUTPUT Cable' plug deeper into the socket to release the lock and to allow the plug to be removed.

Do not force the plug to disconnect without unlocking. It results in damaging both LINE OUTPUT Connector socket and cable plug.



High voltage pulse and power for EUT are output on test. Be sure to install protection cover after completing connection. Mishandling or careless operation may result in a fatal wound. Carefully handle it.

9. Surge output terminal 【SURGE OUTPUT】

Output surge

10. Voltage/Current surge monitor terminal 【V MONITOR / I MONITOR】

Voltage/Current waveform monitor output terminal.

Voltage monitor output ratio is 2000V/V.

Current monitor output ratio is 1000A/V.

The surge can be monitored with connecting the supplied BNC cable to an oscilloscope.



[Voltage surge monitor terminal / Current surge monitor terminal]

Since waveform at the output terminal of the Unit is monitored by monitor terminal, the monitored waveform is different from waveform which is injected to EUT actually. Only voltage peak amplitude under open circuit conditions and current peak amplitude under short circuit conditions are guaranteed while no specifications are given with the EUT connected.

11. POWER switch 【POWER】

Used to turn ON/OFF the Unit, turn to (I) side for ON, (0) side for OFF.

12. Interlock terminal 【INTER LOCK】

Turns ON when 1pin - 3pin is short-circuited so that test is ready. Connect the supplied interlock connector to this terminal.

13. FG terminal 【FG】

FG (Frame Ground) terminal of the Unit. Since the Unit is usually grounded via the AC power supply cable with PE terminal, grounding of this terminal is unnecessary. Unless the Unit is grounded via an AC cable, connect it to the ground via the supplied FG cable.

14. External extension ports 【EXT CONNECTION CDN I/F】

This port is used to control external devices. Not normally used.

9-3. Rear Panel

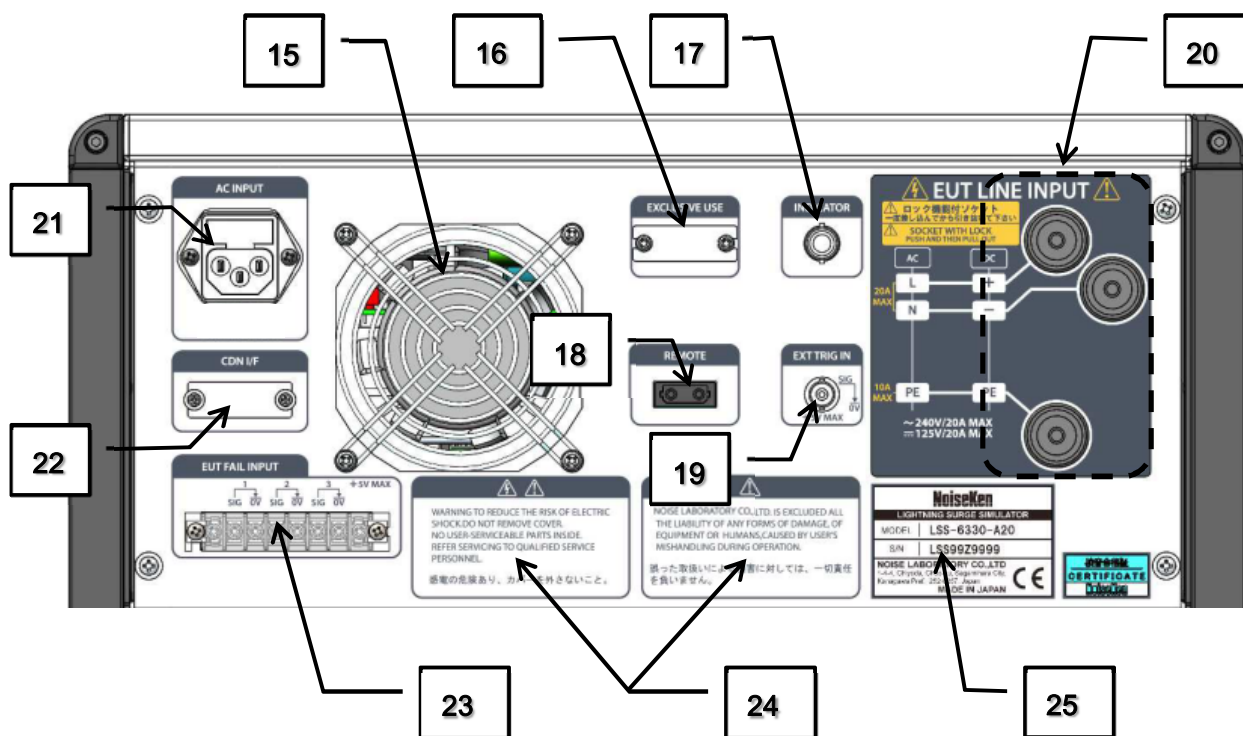

- 15. Fan
Used to radiate internal heat. Avoid blocking ventilation.
- 16. Communication port for servicing **【EXCLUSIVE USE】**
Connector dedicated only to maintenance/servicing. Do not remove cover.
- 17. Warning lamp/pilot lamp port **【INDICATOR】**
An optional warning lamp or tri-color pilot light can be connected.
- 18. Optical communication connector **【REMOTE】**
An extension connector for future options.
Connects the PC on which the remote software is operated via an optical cable.
- 19. External trigger input connector **【EXT TRIG IN】**
BNC coaxial connector for inputting external signal.



Please Refer to 「**External Trigger**⇒P.60」

20. EUT line input terminal 【EUT LINE INPUT】

Safety sockets used for inputting power supply for EUT.

EUT line of the Unit does not have any protection circuit against over voltage or over current.

Prepare a proper protection circuit separately.

Power supply to the EUT shall be connected to EUT LINE INPUT ports by using the supplied line input cables

The EUT LINE INPUT and the accessory cables adopt Snap-in lock system connectors by Staubli Electrical Connectors AG.



This Snap-in system automatically locks-in (with a click sound) cable plug (or a socket) onto panel socket (or a plug) to prevent unwanted disconnection. To unlock, push the line input cable plugs deeper into the socket to release the lock and to allow the plug to be removed.



Do not force the plug to disconnect without unlocking. It results in damaging both LINE OUTPUT Connector socket and cable plug.

21. AC inlet (with fuse) 【AC INPUT】

Input connector for power supply of the Unit, incorporating fuse.

In exchanging fuses, prepare a fuse rated 250 V T 3.15A.

22. External CDN control connector 【CDN I/F】

It is not used for this unit. Do not remove the cover.

23. EUT FAIL input terminal block 【EUT FAIL INPUT】

Inputs signals detecting EUT FAIL (malfunction). When a signal is detected, the Unit will work according to directions set up previously.



Please refer to 「EUT FAIL Signal⇒P.62」

24. Warning on handling

Draws your attention to such points as “exemption from responsibility”, etc.

25. Serial number label

Indicates serial number of the Unit.

10. CONNECTION

10-1. Connecting AC Cord

- ① Insert a proper AC cord into AC inlet 【AC INPUT】 .

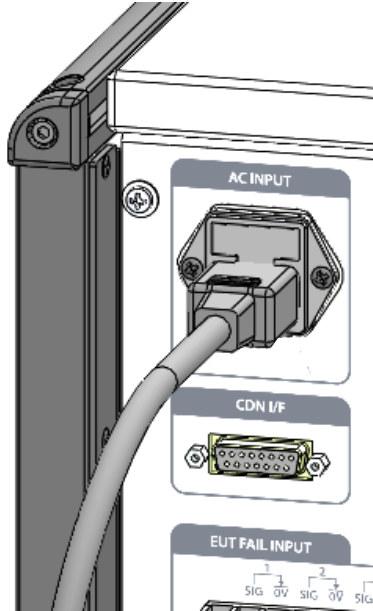

The attached AC cord is for AC100~120 V. In case of AC220~240 V, prepare a 3-line AC cord with PE terminal pin which is conforming to the local safety standard.

- ② Connect the interlock connector to the interlock terminal.

※ Unless the Unit is grounded via the 3 pin AC cable, ground the FG terminal 【FG】 via the supplied FG cable. Be sure to tighten a screw securely.

10—2.Connection of Optical Communication Cable (Optional)

To control the Unit externally (optional), connect a communication cable to the optical communication connector **【REMOTE】** . The communication cable is connected to PC via the optical fiber cable and adaptor.

For details, refer to the instruction manual of the remote software. When communication is started, the display changes as the remote software content changes, but operation on the Unit is unavailable in this status except the following operation.

- Emergency stop button **【EMERGENCY】**
- LINE ON/OFF key **【LINE ON/OFF】** : Only turning OFF is effective.
- STOP key **【STOP】**

10—3.Connection for Applying Surge Waveform to EUT Directly

Connection of Surge Output

- ① Connect the supplied surge output cable to the surge output terminal **【HOT】**, **【COM】**

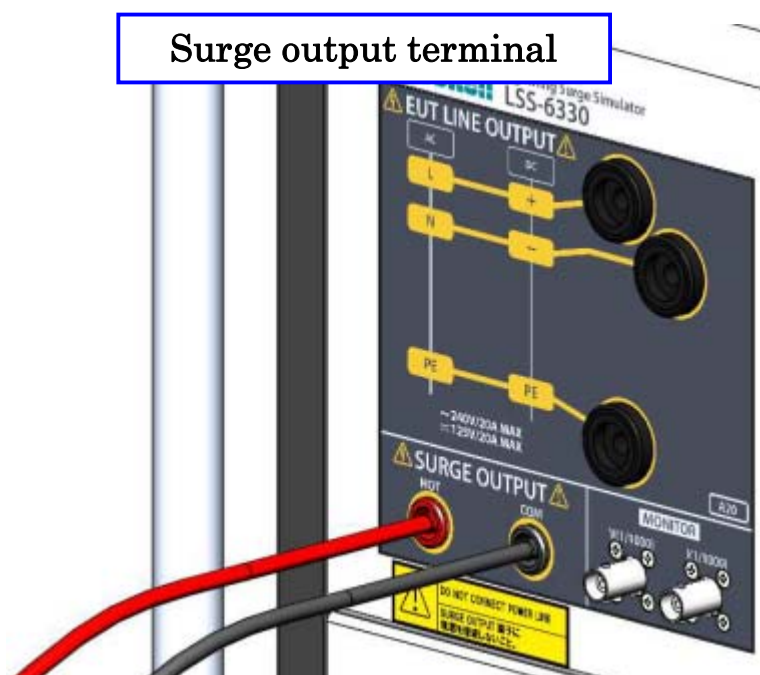

Do not connect any power supply to the surge output terminal **【SURGE OUTPUT HOT · COM】** directly. If an AC power supply or a DC power supply is connected there directly, the Unit may be damaged.



When performing a test, maximum care for safety should be taken. When there is possibility that the EUT could explode, fit a cover to the EUT to assure the safety of the users.

10-4. Connection for Applying Surge Waveform to AC/DC Line

Connection of AC/DC Line Input

Connection of Isolation Transformer

The power line injection unit of the Unit incorporates filters to prevent the surge from returning to the power supply upstream (Those filter are referred to as "Decoupling Network" in the relevant IEC standard.). It consists of LC filter and this simulator adopts $L=1.5\text{mH}$, $C=10\mu\text{F}$. Since the capacitor of this filter is provided between line and line, and between line and PE, electric current flows to the capacitor when AC power is supplied to the AC line input part of this Unit. To eliminate the influence of leak current inside the Unit, an isolation transformer should be provided between AC power supply and the EUT line input.



Be sure to use an isolation transformer between to supply to the EUT line in terminal of the Unit. If AC power is directly supplied without using an isolation transformer, the ground fault circuit interrupter installed in the test site acts to OPEN the circuit. When wiring, be sure to turn off power supply input to the insulation transformer beforehand.



Since residual voltage (maximum 1kV) occurs at the input/output terminal of the isolation transformer, be sure to use the isolation transformer which is able to withstand this voltage.

- ① Before connecting, ensure that power supply to the EUT is turned off and that the Unit is in OFF status.



- The EUT supply connection shall be made by using the included LINE INPUT cables.
- The cables have the following colors for easier identification. Use within the specified ratings. AC240 V/20 A, DC125 V/20 A MAX
- EUT line of the Unit does not have any protection circuit against over voltage or over current. Prepare a proper protection circuit separately.

- ② Connect the supplied line input cables to the line input connectors 【EUT LINE INPUT】 on the rear panel section. Insert the cable plug to the input connector until a click sound is heard, the snap-in lock system automatically locks the plug and socket and the cable cannot be pulled out from the socket. To unlock, push the plug deeper into the socket to release lock and to allow the plug to be removed.

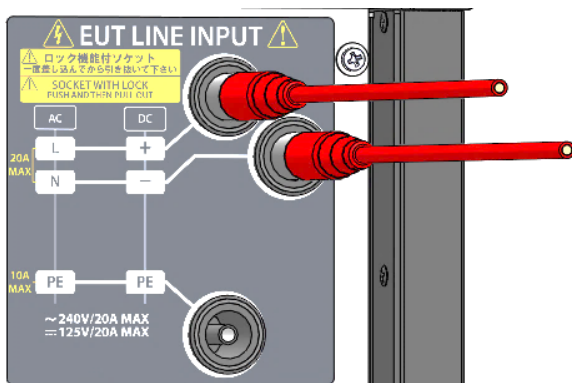

Without PE line

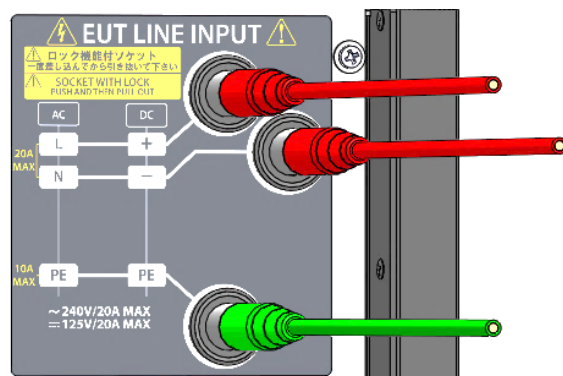

With PE line

(*Single-phase three-wire connection is not possible.)



Do not force the plug to disconnect without unlocking. It results in damaging both LINE OUTPUT Connector socket and cable plug.

Connection of AC/DC Line Output

- ① Connect the attached line output cable to the AC / DC line output terminal 【EUT LINE OUTPUT】 of the AC / DC line superimposition section. See the connection diagram below.

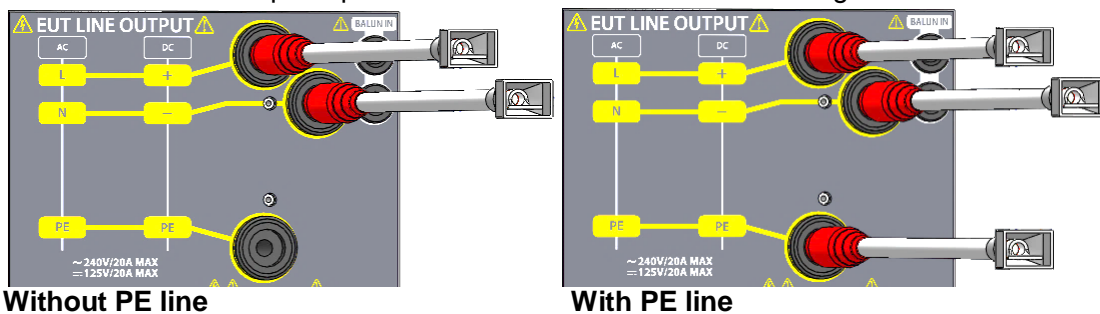

- ② Connect EUT to the tip of the surge output cable. If the surge output cable and the connecting part are worked for the test with insulation tubes, the surge test can be performed more safely. However, it is necessary to use an insulated tube with dielectric strength of 6.7kV or more. Moreover, as creeping discharge sometimes occurs on the surface of parts, it is also necessary to take into consideration the dielectric strength to creeping discharge



When performing a test, maximum care for safety should be taken. When there is possibility that the EUT could explode, fit a cover to the EUT to assure the safety of the users.

11. OPERATION

11-1. Power ON unit

- 1 Turn on the Unit with POWER switch on front panel of the Unit.
- 2 When the Unit is turned on and starts normally, an electronic sound goes off, main menu is displayed on LCD touch panel, and a fan in rear side starts working.

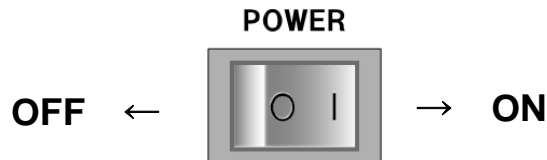

Main menu is displayed as default when the Unit is first turned on after shipment. The screen displayed when the Unit is turned on can be set on "UTILITY" screen. Refer to 15. UTILITY. 「Power ON Display - P.59」

11-2. Emergency Stop Button

Emergency stop button is just for emergency. Do not use it to stop usual operation.



In case it is pressed while test is conducted, the test status can be checked with touching 『OK』.

When emergency stop button is pressed, the Unit shifts to the following status forcibly.

- ◆ The test is immediately stopped and high voltage generating circuit of the Unit is turned off.
- ◆ EUT power supply (EUT LINE switch) is turned off by force.
- ◆ When emergency stop button is pressed, operation is prohibited until the Unit is turned on again.

How to cancel emergency stop

1. Turn off the Unit with POWER switch of the Unit.
2. Rotate emergency stop button clockwise to release the status. Turn on the Unit again with POWER switch

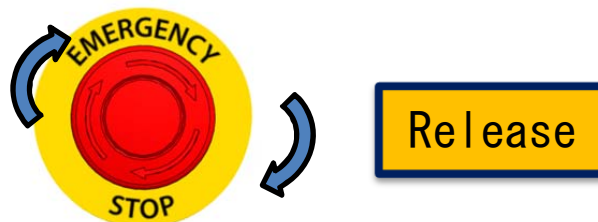

In releasing emergency stop status and turning on the Unit again, remove the cause of pressing emergency stop button and ensure safety fully.



If emergency stop status is released when POWER switch of the Unit is ON, every operation is prohibited until the Unit is turned on again.

11 – 3. Main Menu

The Unit adopts a touch-panel-type LCD which enables image-oriented operation with graphic display. When the main menu is displayed, touch the panel to select a function to be used.

As the main menu is always displayed when the menu switch is pressed, easy moving to another screen is available. (This function is unavailable while conducting test.)

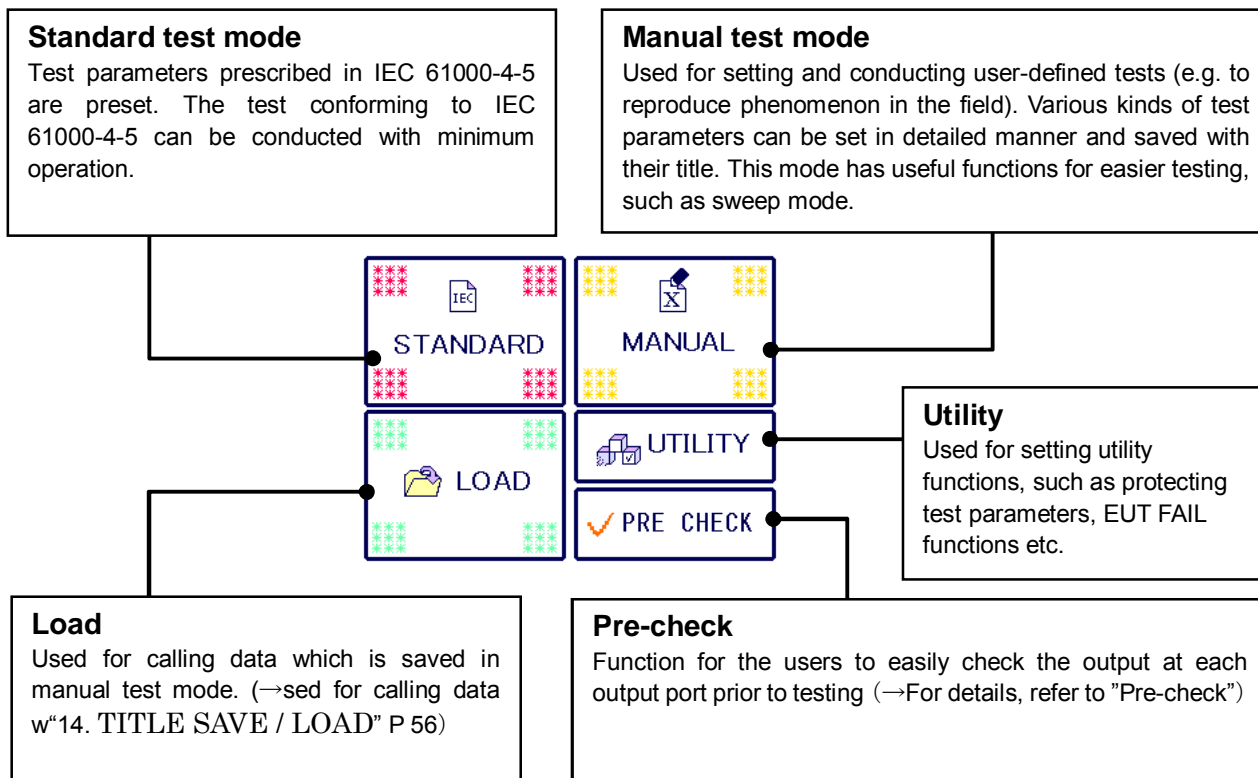

11-4. Screen Flowchart

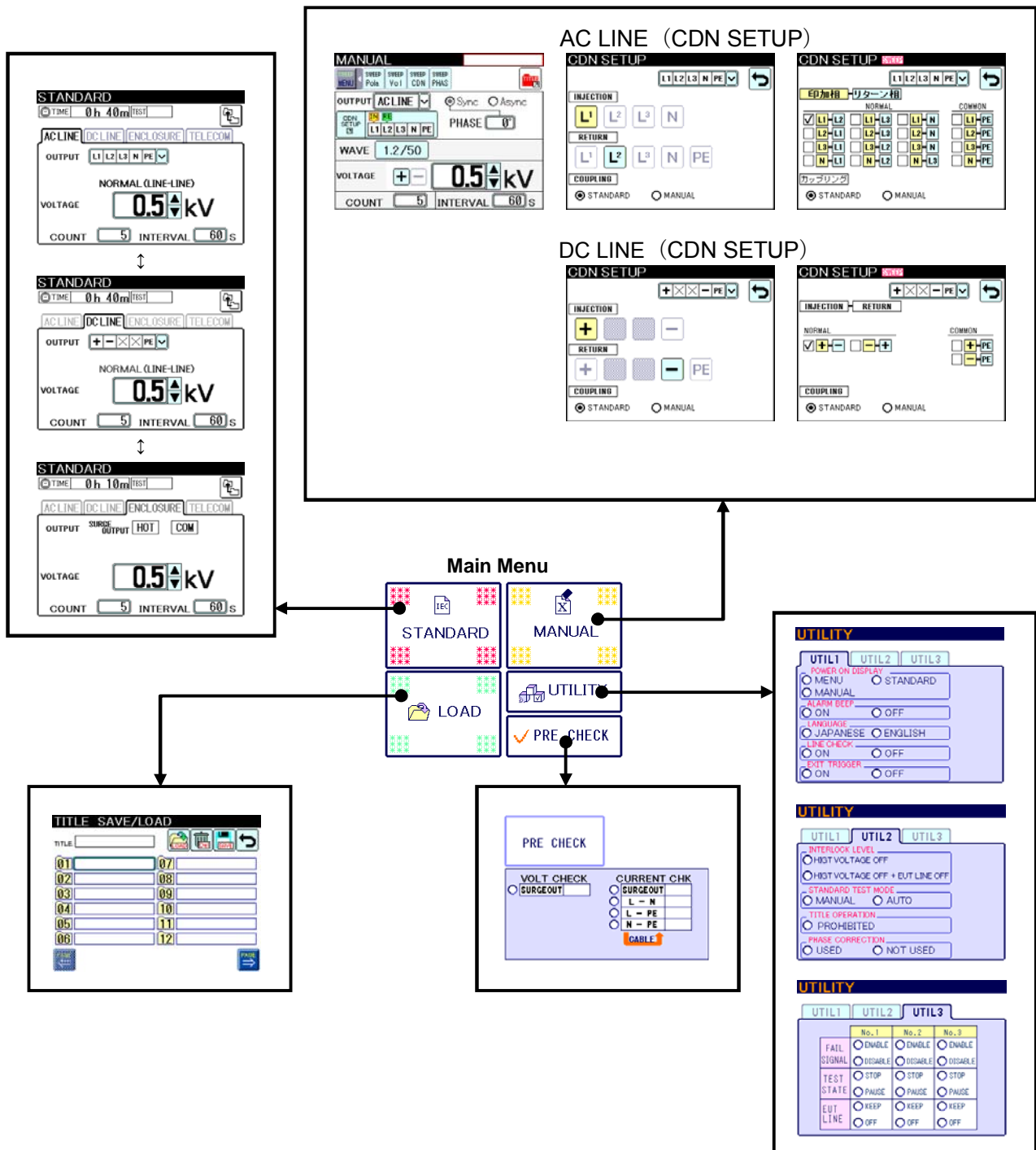

11 – 5. Inputting Numbers and Letters (About Ten Key and Character Key)

The ten key is displayed for inputting numbers, the character key is displayed for operation for title. Basic operations of them are as follows. Touch the item which is necessary to be input and the ten key is displayed with the value as in the last usage.

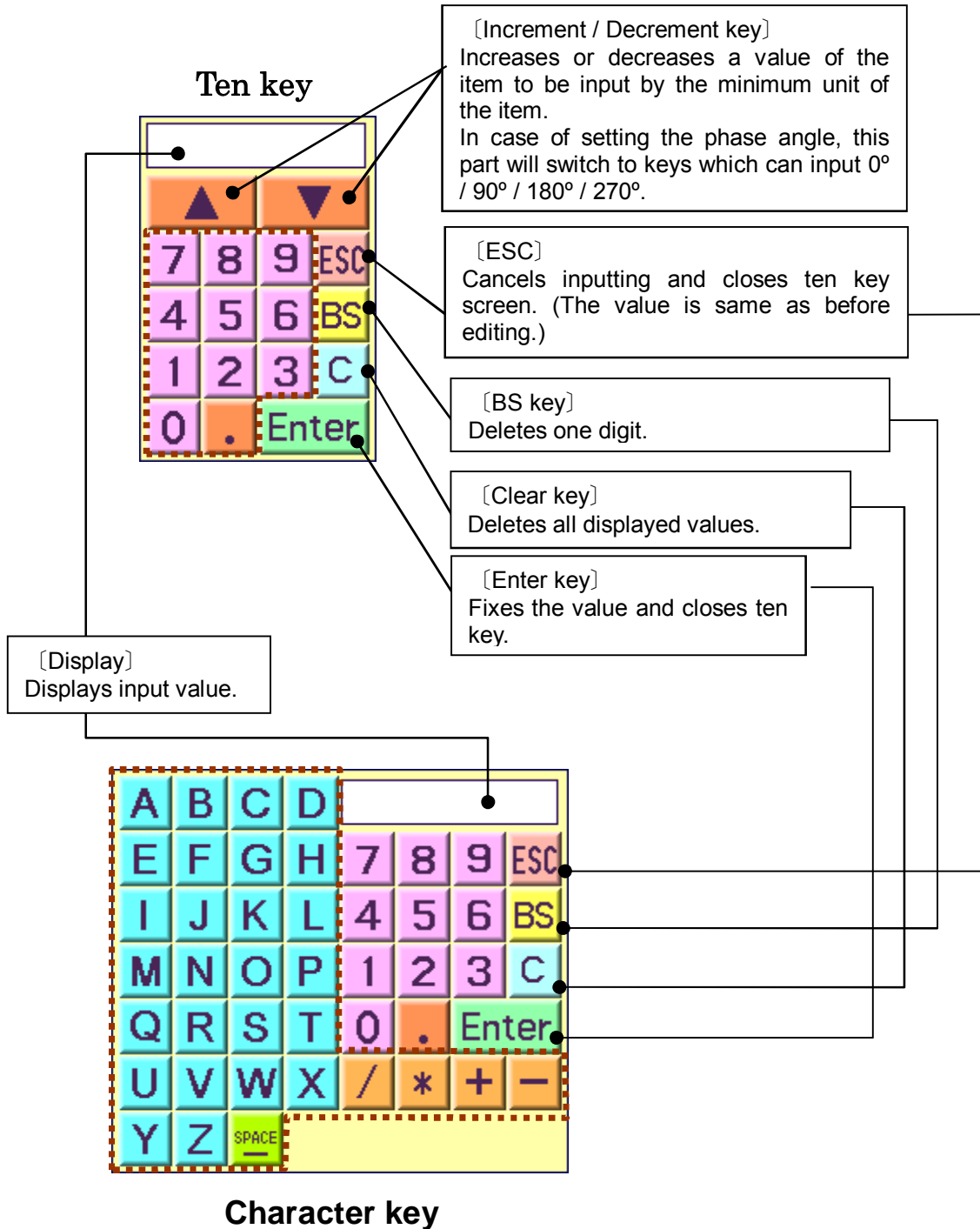

12. STANDARD TEST

12-1. Setting Standard Test

 Touch 『STANDARD』 on the main menu.

In the standard test mode, the test conditions prescribed on the IEC61000-4-5 are preset. The test list is made automatically only with inputting the output way and voltage according to the user's EUT line. If any other test condition than the standard test is needed, set with the manual test mode (Refer to 13.MANUAL TEST →P.41).

Example) The test list in case of;

Output: AC LINE, Output line: L/N/PE, Normal mode voltage: 0.5kV, Common mode voltage: 1.0kV

Table 12-1. Test list

1.2/50 μ s surge waveform						
Output: AC/DC line output terminal 【AC/DC LINE OUTPUT】						
Test No.	Mode	Polarity	Voltage	Injection phase	Return phase	Phase angle
1	Normal mode	+	0.5kV	L	N	0°
2						90°
3						180°
4						270°
5		-	0.5kV	L	N	0°
6						90°
7						180°
8						270°
9	Common mode	+	1.0kV	L	PE	0°
10						90°
11						180°
12						270°
13		-	1.0kV	L	PE	0°
14						90°
15						180°
16						270°
17		+	1.0kV	N	PE	0°
18						90°
19						180°
20						270°
21		-	1.0kV	N	PE	0°
22						90°
23						180°
24						270°

The estimate test time is displayed with conditions previously input.

Standard test setting screen

If this button is pressed, a message box asking whether moving to the manual test mode or not will appear. If 『yes』 is selected, the screen will move to the manual test setting screen with holding all of set data. As for voltage, the set value is moved (The normal mode value is prioritized). This function is useful for making a new test format based on IEC test with changing some conditions of it.

Set the discharge times.

Press and the ten key is displayed.

Input the times and press Enter to fix the value.
1~999 times 1 time step

Set the interval time.

Press and the ten key is displayed.

Input the interval time (second) and press Enter to fix the value.
1.2/50 waveform selected: 5~999s 1s step
Minimum value
4.0kV or less: 5 seconds
4.1kV or more: 10seconds

10/700 waveform selected: 10~999s 1s step
Minimum value
4.0kV or less: 10 seconds
4.1kV or more: 15 seconds

1.2/50 waveform selected: 1~999s 1s step
Minimum value
4.0kV or less: 1 seconds
4.1kV or more: 3 seconds

Set the surge voltage.

If AC LINE or DC LINE is selected, setting normal mode voltage and common mode voltage is available depending on the selected EUT line.

Normal mode (without PE)

NORMAL (LINE-LINE)

Normal / Common mode (with PE)

NORMAL (LINE-LINE) kV

COMMON (LINE-PE) kV

Press and the ten key is displayed. 0.0~6.7kV 0.1kV step. (0.01kV step for less than 2.00kV)
Setting 0.1kV step with ▲/▼ is available only in the normal mode.
(The voltage range as the guaranteed waveform on the specification is 0.5~6.7kV (RING 0.25~6.6kV).)

33

Discharge Interval

The first surge after the test start is output when the minimum charging time (Refer to the previous page) has passed without any relationship with the set interval.

12-2.AC LINE Standard

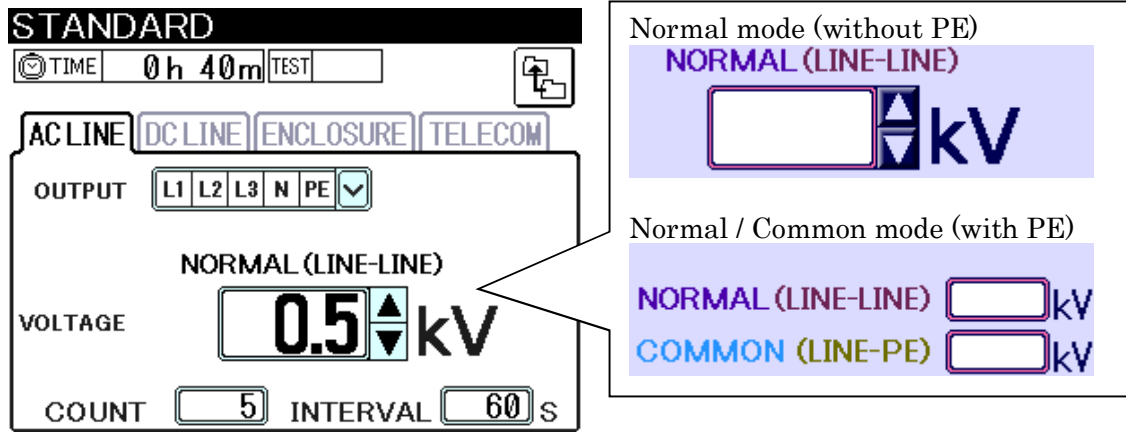

- ① For injecting surge to the AC line, touch 『AC LINE』 on the above tab.
The surge is output from the AC/DC line output terminal 【AC/DC LINE OUTPUT】 .
- ② Select EUT line.
Touch to indicate single-phase without PE (L/N) / Single-phase with PE (L/N/PE).
Select the EUT line depending on the EUT.



Fully pay attention to connection of the line input and the line output.

There should be no discrepancy between the actual connection and setting on the screen. Refer to 10. CONNECTION.

- ③ Set voltage, count, and interval.

12-3.DC LINE Standard

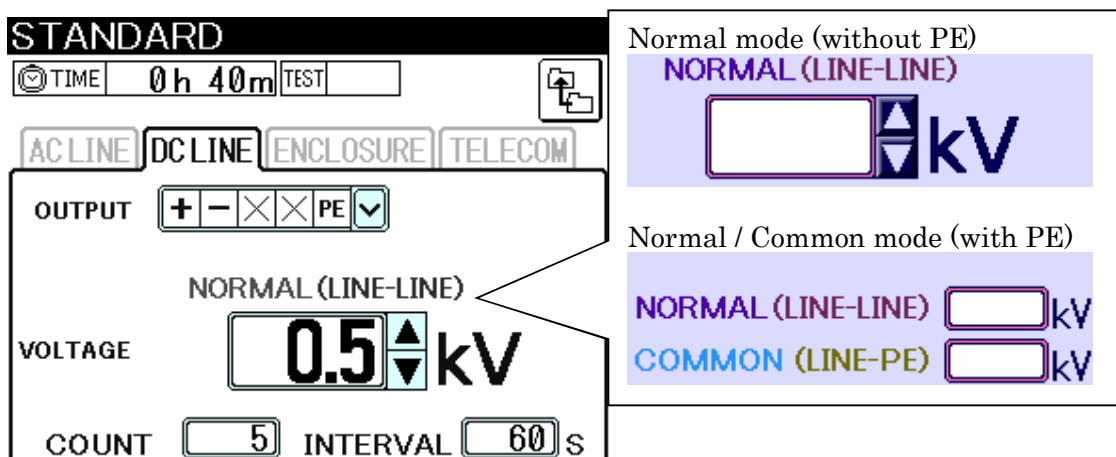

- ① For injecting surge to the DC line, touch 『DC LINE』 on the above tub.
The surge is output from the AC/DC line output terminal 【AC/DC LINE OUTPUT】 .
- ② Select EUT line.
Touch to indicate single-phase without PE (L/N) / Single-phase with PE (L/N/PE).
Select the EUT line depending on the EUT.



Fully pay attention to connection of the line input and the line output.

 There should be no discrepancy between the actual connection and setting on the screen. Refer to 10. CONNECTION.

- ③ Set voltage, count, and interval.

12-4.ENCLOSURE Standard

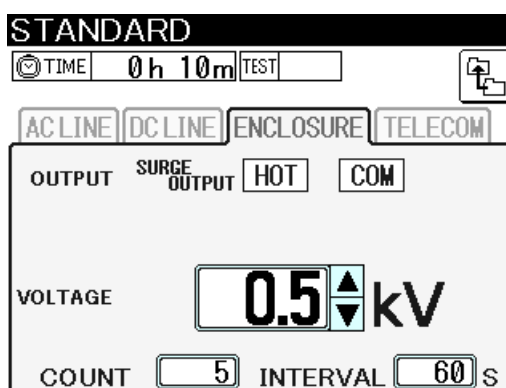

- ① For injecting surge to the EUT directly, touch 『ENCLOSURE』 on the above tub.
The surge is output from the surge output terminal 【SURGE OUTPUT】
- ② Set voltage, count, and interval

12-5.Executing Standard Test

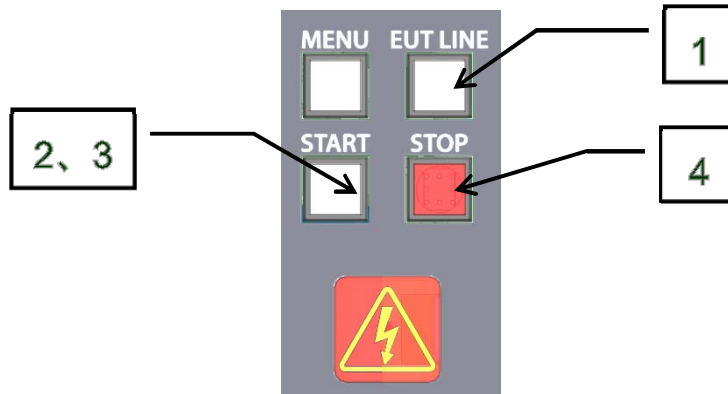

- ① In case of the injection test to power lines, turn ON the line breaker of lines to be tested.
- ② Power supply to the EUT
In case of the injection test to power lines, press the EUT LINE key【EUT LINE】to connect the line. The LED of the EUT LINE key illuminates when power is supplied.



Since the line power supply is output to the AC/DC line output terminal 【AC/DC LINE OUTPUT】 when the EUT LINE key is turned ON, fully be careful to the terminals for safety.

- ③ Check screen
Press START key to complete all conditions for test and to indicate the following check screen. Confirm the whole condition and press the START key again to start the test. (Changing the test order is not available.) If there is any dissatisfied condition, an error message will appear. if  touched on the check screen, the screen will return to the standard test setting screen.

The screenshot shows the 'CHECK TEST SETTINGS' screen. At the top, it says 'CHECK TEST SETTINGS'. Below this are several fields: 'C/W' with values 1.2 and 5.0, 'COUNT' set to 5, 'TEST' set to 24, and 'INTERVAL' set to 60s. There are also icons for 'PAGE', a return arrow, and 'PAGE'. Below these are three buttons: 'PAGE', a return arrow, and 'PAGE'. The main part of the screen is a table with 8 rows of test settings. Callouts point to various parts of the screen: 'Discharge times' points to the 'COUNT' field; 'Discharge interval' points to the 'INTERVAL' field; 'Turning page' points to the 'PAGE' buttons; 'Waveform' points to the 'C/W' field; 'Total number of the tests' points to the 'TEST' field; 'Test No.' points to the 'No.' column of the table; 'Injection' points to the 'MODE' column; 'Polarity' points to the 'Pola' column; 'Surge voltage' points to the 'VOLTAGE' column; 'Output to' points to the 'OUTPUT' column; and 'Executing test frame' points to the first row of the table.

No.	MODE	Pola	VOLTAGE	OUTPUT
1	NOR	+	0.5kV	IN L RE N 0°
2	NOR	+	0.5kV	IN L RE N 90°
3	NOR	+	0.5kV	IN L RE N 180°
4	NOR	+	0.5kV	IN L RE N 270°
5	NOR	-	0.5kV	IN L RE N 0°
6	NOR	-	0.5kV	IN L RE N 90°
7	NOR	-	0.5kV	IN L RE N 180°
8	NOR	-	0.5kV	IN L RE N 270°

For selecting the opening test

If the specific test number is touched and the START key is pressed again on the check screen, the test starts with the specific test number.

Example) If you like to start with the No. 5 test, touch the No. 5 to move the executing test frame to the No.5.

①

CHECK TEST SETTINGS						
C/W	1.2	5.0	COUNT	5	PAGE	PAGE
TEST	24	INTERVAL	60s			
No.	MODE	Pola	VOLTAGE	OUTPUT		
1	NOR	+	0.5kV	IN	L	RE N
2	NOR	+	0.5kV	IN	L	RE N
3	NOR	+	0.5kV	IN	L	RE N
4	NOR	+	0.5kV	IN	L	RE N
5	NOR	-	0.5kV	IN	L	RE N
6	NOR	-	0.5kV	IN	L	RE N
7	NOR	-	0.5kV	IN	L	RE N
8	NOR	-	0.5kV	IN	L	RE N

②

CHECK TEST SETTINGS						
C/W	1.2	5.0	COUNT	5	PAGE	PAGE
TEST	24	INTERVAL	60s			
No.	MODE	Pola	VOLTAGE	OUTPUT		
1	NOR	+	0.5kV	IN	L	RE N
2	NOR	+	0.5kV	IN	L	RE N
3	NOR	+	0.5kV	IN	L	RE N
4	NOR	+	0.5kV	IN	L	RE N
5	NOR	-	0.5kV	IN	L	RE N
6	NOR	-	0.5kV	IN	L	RE N
7	NOR	-	0.5kV	IN	L	RE N
8	NOR	-	0.5kV	IN	L	RE N

Touch

Example) If you like to start with the No. 13 test, touch 『PAGE』 to move to the next page, and touch the No. 13 to move the executing test frame to the No.13.

①

CHECK TEST SETTINGS						
C/W	1.2	5.0	COUNT	5	PAGE	PAGE
TEST	24	INTERVAL	60s			
No.	MODE	Pola	VOLTAGE	OUTPUT		
1	NOR	+	0.5kV	IN	L	RE N
2	NOR	+	0.5kV	IN	L	RE N
3	NOR	+	0.5kV	IN	L	RE N
4	NOR	+	0.5kV	IN	L	RE N
5	NOR	-	0.5kV	IN	L	RE N
6	NOR	-	0.5kV	IN	L	RE N
7	NOR	-	0.5kV	IN	L	RE N
8	NOR	-	0.5kV	IN	L	RE N

②

CHECK TEST SETTINGS						
C/W	1.2	5.0	COUNT	5	PAGE	PAGE
TEST	24	INTERVAL	60s			
No.	MODE	Pola	VOLTAGE	OUTPUT		
9	COM	+	1.0kV	IN	L	RE PE
10	COM	+	1.0kV	IN	L	RE PE
11	COM	+	1.0kV	IN	L	RE PE
12	COM	+	1.0kV	IN	L	RE PE
13	COM	-	1.0kV	IN	L	RE PE
14	COM	-	1.0kV	IN	L	RE PE
15	COM	-	1.0kV	IN	L	RE PE
16	COM	-	1.0kV	IN	L	RE PE

Touch

③

CHECK TEST SETTINGS						
C/W	1.2	5.0	COUNT	5	PAGE	PAGE
TEST	24	INTERVAL	60s			
No.	MODE	Pola	VOLTAGE	OUTPUT		
9	COM	+	1.0kV	IN	L	RE PE
10	COM	+	1.0kV	IN	L	RE PE
11	COM	+	1.0kV	IN	L	RE PE
12	COM	+	1.0kV	IN	L	RE PE
13	COM	-	1.0kV	IN	L	RE PE
14	COM	-	1.0kV	IN	L	RE PE
15	COM	-	1.0kV	IN	L	RE PE
16	COM	-	1.0kV	IN	L	RE PE

④

CHECK TEST SETTINGS						
C/W	1.2	5.0	COUNT	5	PAGE	PAGE
TEST	24	INTERVAL	60s			
No.	MODE	Pola	VOLTAGE	OUTPUT		
9	COM	+	1.0kV	IN	L	RE PE
10	COM	+	1.0kV	IN	L	RE PE
11	COM	+	1.0kV	IN	L	RE PE
12	COM	+	1.0kV	IN	L	RE PE
13	COM	-	1.0kV	IN	L	RE PE
14	COM	-	1.0kV	IN	L	RE PE
15	COM	-	1.0kV	IN	L	RE PE
16	COM	-	1.0kV	IN	L	RE PE

Touch

④ Conducting test

First, 『Test is being prepared』 is indicated. When switching the internal circuit is complete, 『UNDER TEST』 appears on the screen. The warning lamp is blinking while the test is conducted. The discharge times counts up and the interval counts down.

⚠ UNDER TEST ⚠ WARNING ⚠											
C/W	1.2	5.0	COUNT	5	0.47	kV	0.01	ka	MONITOR		
TEST	24	INTERVAL	60s								
No.	MODE	Pola	VOLTAGE	OUTPUT							
1	NOR	+	0.5kV	IN	L	RE	N	0°			
2	NOR	+	0.5kV	IN	L	RE	N	90°			
3	NOR	+	0.5kV	IN	L	RE	N	180°			
4	NOR	+	0.5kV	IN	L	RE	N	270°			
5	NOR	-	0.5kV	IN	L	RE	N	0°			
6	NOR	-	0.5kV	IN	L	RE	N	90°			
7	NOR	-	0.5kV	IN	L	RE	N	180°			
8	NOR	-	0.5kV	IN	L	RE	N	270°			



High voltage surges are output. Mishandling or careless operation may result in a fatal wound. Carefully handle it.

⑤ Moving to the next test

When one test stage is complete, the completion check is indicated in the column. If the sequence method on the “Utility” is “AUTO”, the test stage moves to the next automatically. If “MANUAL”, 『Press START key to prepare next test』 is indicated, press the START key to start the next test. The executing test frame moves to the next test.

⚠ UNDER TEST ⚠ WARNING ⚠											
C/W	1.2	5.0	COUNT	5	0.10	kV	0.22	ka	Completion check		
TEST	24	INTERVAL	60s								
No.	MODE	Pola	VOLTAGE	OUTPUT							
1	NOR	+	0.5kV	IN	L	RE	N	0°	✓		
2	NOR	+	0.5kV	IN	L	RE	N	90°	✓		
3	NOR	+	0.5kV	IN	L	RE	N	180°			
4	NOR	+	0.5kV	IN	L	RE	N	270°			
5	NOR	-	0.5kV	IN	L	RE	N	0°			
6	NOR	-	0.5kV	IN	L	RE	N	90°			
7	NOR	-	0.5kV	IN	L	RE	N	180°			
8	NOR	-	0.5kV	IN	L	RE	N	270°			

Conducting one by one



As for the sequence method, set it on the utility. Refer to 15. UTILITY.



In moving to the next test stage, ‘Pause’ is not available.

Pause

Pressing the START key while conducting test makes the output pausing. The START key is blinking and 『PAUSE』 is indicated on the screen. For restarting the test, press the START key again. While pausing, the restarting test can be changed. Since the operation is same as selecting the opening test..

PAUSE						
C/W	1.2 / 5.0	COUNT	5			
TEST	24	INTERVAL	60s			
No.	MODE	Pola	VOLTAGE	OUTPUT		
1	NOR	+	0.5kV	IN	L RE N	0° ✓
2	NOR	+	0.5kV	IN	L RE N	90° ✓
3	NOR	+	0.5kV	IN	L RE N	180°
4	NOR	+	0.5kV	IN	L RE N	270°
5	NOR	-	0.5kV	IN	L RE N	0°
6	NOR	-	0.5kV	IN	L RE N	90°
7	NOR	-	0.5kV	IN	L RE N	180°
8	NOR	-	0.5kV	IN	L RE N	270°



If 『PAUSE』 status is left as is for 10 minutes, the test will be stopped automatically for safety.

Suspension

Pressing the STOP key while conducting test makes the test stop at the moment. The START key lights off and 『Test suspended』 is indicated on the screen.



Confirming suspension, touch **OK** to return to the standard test setting screen.



Test suspended



Starting the test again on this screen is not available. For restarting, touch **OK** to return to the standard test setting screen and start again on that screen. Even if the test is suspended, the EUT line key is not turned OFF. For turning it OFF, manual operation is necessary.

⑥ Completion of test

The test is ended automatically when the entire set test is complete. The START key lights off and 『Test Completed.』 Is indicated on the screen.

 Confirming completion, touch  to return to the standard test setting screen.

Test Completed									
C/W	1.2	5.0	COUNT	5					
TEST	24	INTERVAL	60s						
No.	MODE	Pola	VOLTAGE	OUTPUT					
17	COM	+	10.0kV	IN	N	RE	PE	0°	✓
18	COM	+	10.0kV	IN	N	RE	PE	90°	✓
19	COM	+	10.0kV	IN	N	RE	PE	180°	✓
21	COM	+	10.0kV	IN	N	RE	PE	270°	✓
20	COM	-	10.0kV	IN	N	RE	PE	0°	✓
22	COM	-	10.0kV	IN	N	RE	PE	90°	✓
23	COM	-	10.0kV	IN	N	RE	PE	180°	✓
24	COM	-	10.0kV	IN	N	RE	PE	270°	✓



- Starting test again on this screen is not available. For restarting, touch  to return to the standard test setting screen and start again on that screen. When test is complete, the Unit provides a lag for eliminating electricity of the internal circuit. Elimination needs about 4 seconds. For safety, restarting is not available during that period.
- In case of conducting test with the EUT LINE key ON, when the LINE key is turned OFF, not only power supply is shut down, but also surge generation is stopped.
- When test is suspended or completed, the LINE key is not turned off automatically. Turn it off manually.

13. MANUAL TEST

13-1. Setting Manual Test

☞ Touch 『MANUAL』 on the main menu.

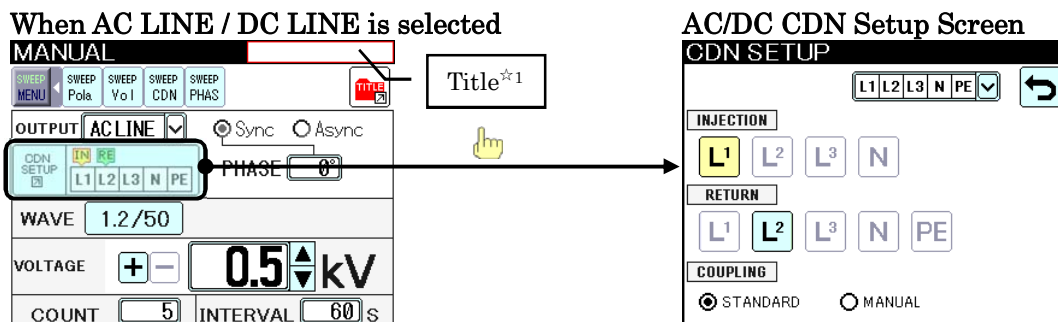

☆1 Title is indicated when the setup content is saved.

List of icons for operation

Icon of key	Remarks
	Used for saving a set content under a title and for calling it again. →For details, refer to “14. TITLE SAVE / LOAD”
	Used for moving to the AC/DC CDN setup screen or the TELECOM CDN setup screen. The settings set up on the CDN setup screen indicates on this icon. indicates the injection phase, indicates the return phase. indicates both of the injection and return phase set on this line in the injection phase sweep mode.
	Used for turning ON/OFF the sweep function. When key is pressed, the menu bar appears (or disappears). In case the sweep function is set, the menu bar is fixed (indicated). Sweep function of polarity 『Pola』, surge voltage 『Vol』, output line 『CDN』, and/or phase angle『PHASE』can be selected. When TELECOM is selected, output from AC/DC CDN and PHASE control is not available.

Sweep function

The sweep function of polarity 『Pola』 , surge voltage 『Vol』 , output line 『CDN』 , and/or phase angle 『PHASE』 can be selected. As for the surge voltage and the phase angle (Only when the surge is output to the AC line and phase angle synchronization is selected), the start value (START), the stop value (STOP), and step value can be input to utilize this function. The order of executing each sweep is fixed as the following flow chart. The value of the item which is not set the sweep mode is fixed.

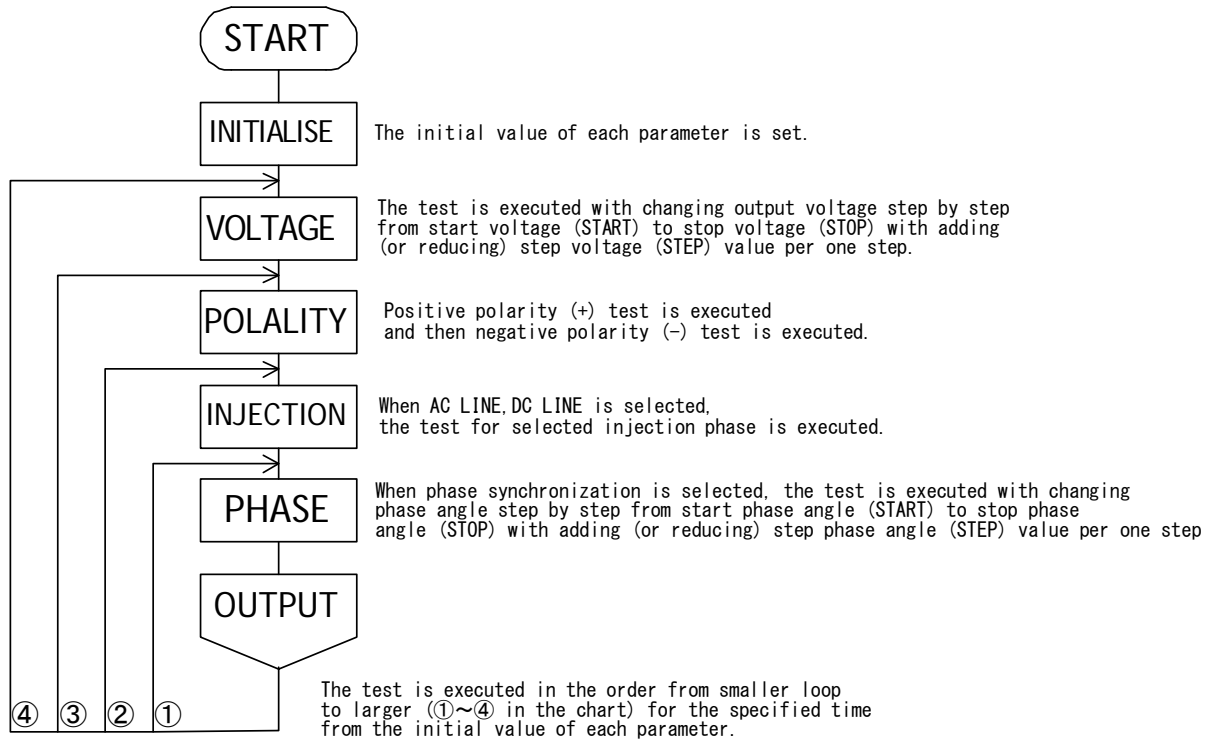

When  key is pressed, the menu bar appears (or disappears).

For setting the sweep function, indicate the menu bar and touch the item to be swept. In case that the sweep function is not used, the menu bar can be hidden. Once the sweep function is set, the menu bar is fixed (indicated).

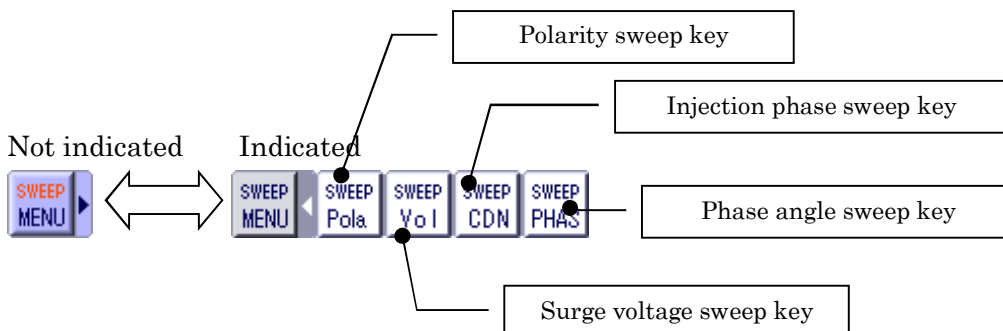

Selecting Output

Select which terminal the surge is output to.

☞ Touch .

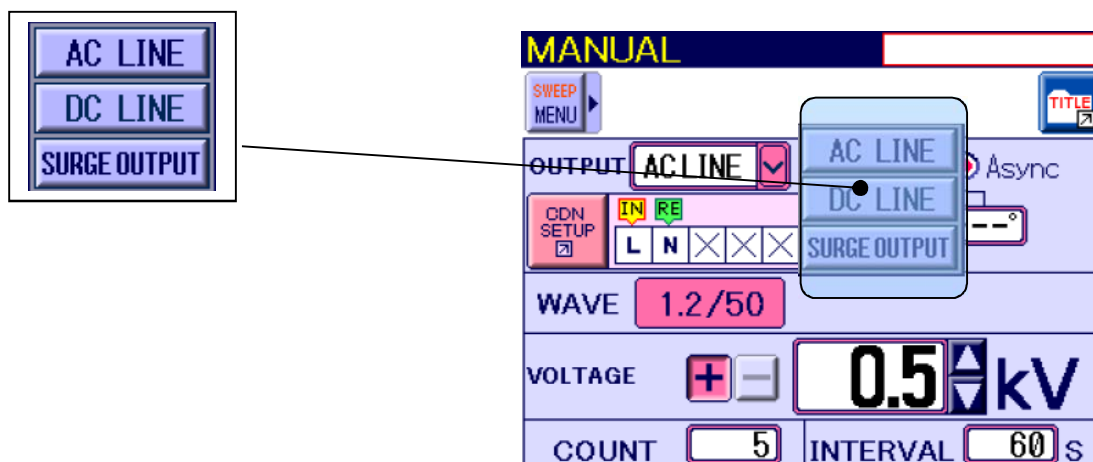

- For injecting surge to the AC line, select 『AC LINE』 .
The surge is output from the AC/DC line output terminal 【AC/DC LINE OUTPUT】 .
- For injecting surge to the DC line, select 『DC LINE』 .
The surge is output from the AC/DC line output terminal 【AC/DC LINE OUTPUT】 .
- For injecting surge to the EUT directly, select 『SURGE OUTPUT』 .
The surge is output from the surge output terminal 【SURGE OUTPUT】 .



Fully pay attention to connection of the line input and the line output.

☞ There should be no discrepancy between the actual connection and setting on the screen.

Selecting Synchronization (Phase Angle) / Synchronization

When 『AC LINE』 is selected as the output, surge injection synchronized with AC line of the EUT power supply is available.

☞ Touch the check box of Sync or Async (●).

When Sync is selected, the phase angle can be set.

☞ Touch of PHASE and input the value. ⓘ 0~360° 1° step

There are 0° / 90° / 180° / 270° keys on the ten key for setting the phase angle.

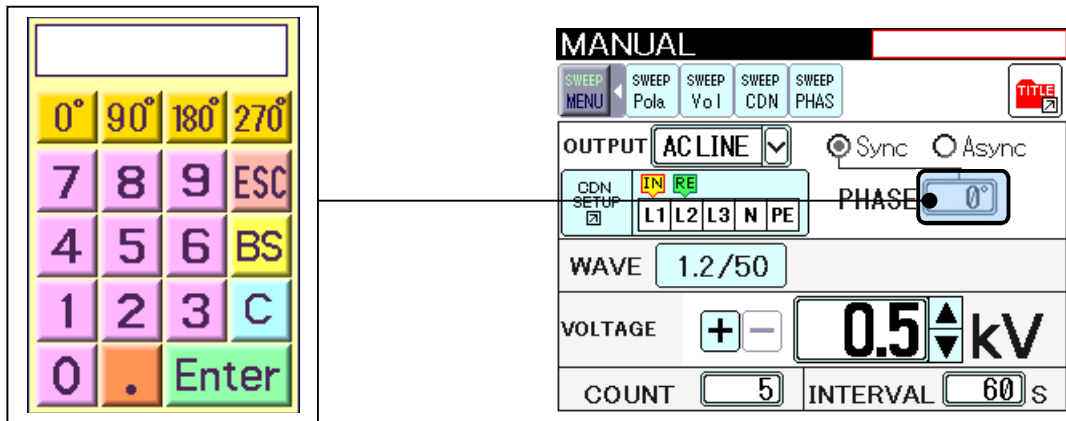

Phase angle sweep

Touching SWEEP PHAS on the sweep menu bar enables setting the phase angle sweep.

(frame) of the starting angle (START), stopping angle (STOP), and step angle (STEP) are indicated. Touch of each column to indicate the ten key. Enter the value of the phase angle and press Enter.

For releasing the sweep, touch SWEEP PHAS again.

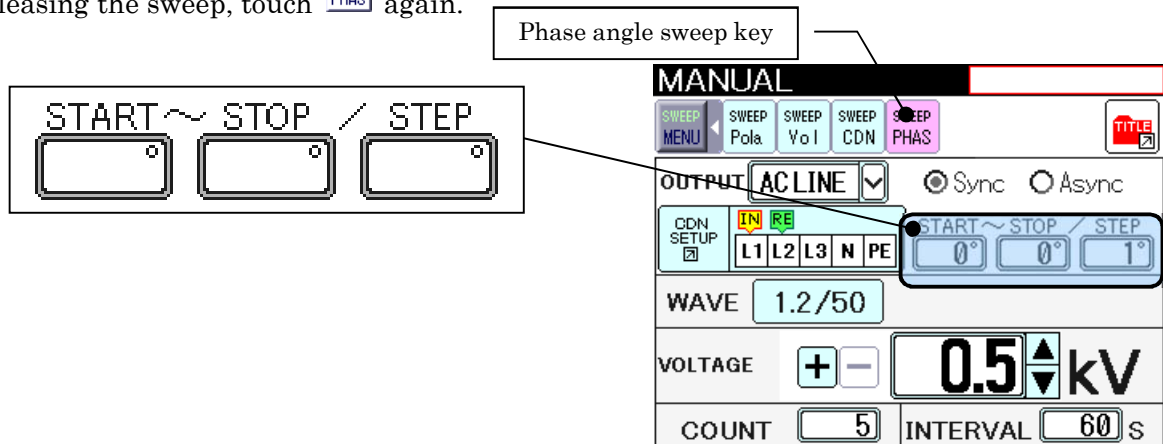

- ⓘ The values are restricted as Starting value (START) ≤ Stopping value (STOP), Step value (STEP) ≥ 1.

Selecting Waveform

Touch 1.2/50 10/700 RING12 RING30

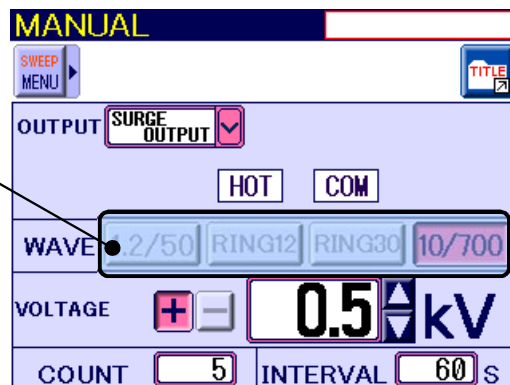

- In case OUTPUT is set as AC LINE or DC LINE, 『1.2/50』 『RING12』 『RING30』 is selectable.
- In case OUTPUT is set as SURGE OUT, 『1.2/50』 『10/700』 『RING12』 『RING30』 is selectable.

Selecting Polarity

Touch + or -

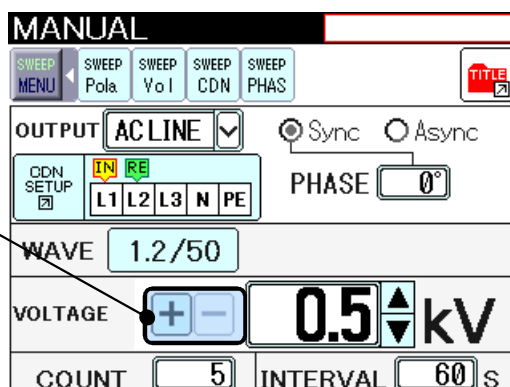

Polarity sweep

Touching SWEEP Pola on the sweep menu bar enables setting the polarity sweep.

The indication is fixed as +▶-, which means the test is conducted as positive (+)→negative (-) order in the polarity sweep.

For releasing the sweep, touch SWEEP Pola again.

Polarity sweep key

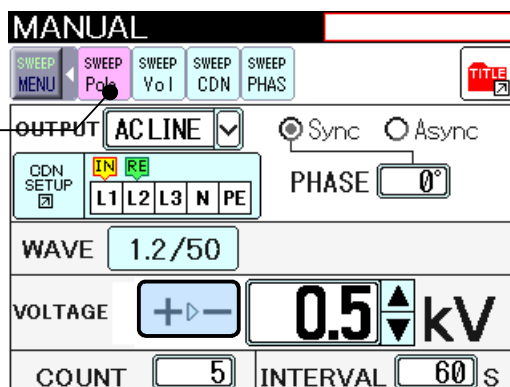

Setting Voltage

Touch of VOLTAGE to indicate the ten key.

 0.0~6.7kV 0.1kV step (Ring wave is 6.6kV max)

Setting voltage with ▲/▼ key on the right side of the column is also available instead of indicating the ten key (Also as 0.1kV step).

(The voltage range as the guaranteed waveform on the specification is 0.5~6.7kV.(Ring wave is 0.25-6.6kV))

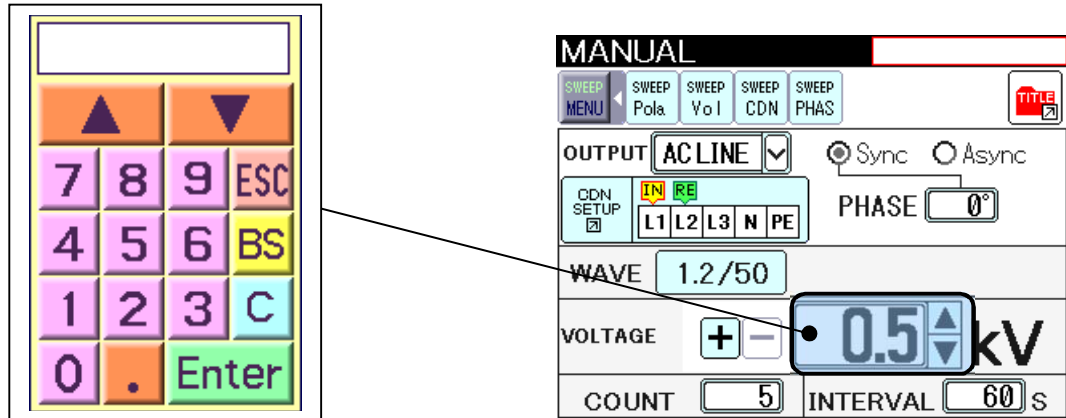

Voltage sweep

Touching  on the sweep menu bar enables setting the voltage sweep.

(frame) of the starting voltage (START), stopping voltage (STOP), and step voltage (STEP) are indicated. Touch of each column to indicate the ten key. Enter the value of the voltage and press Enter.

For releasing the sweep, touch  again.

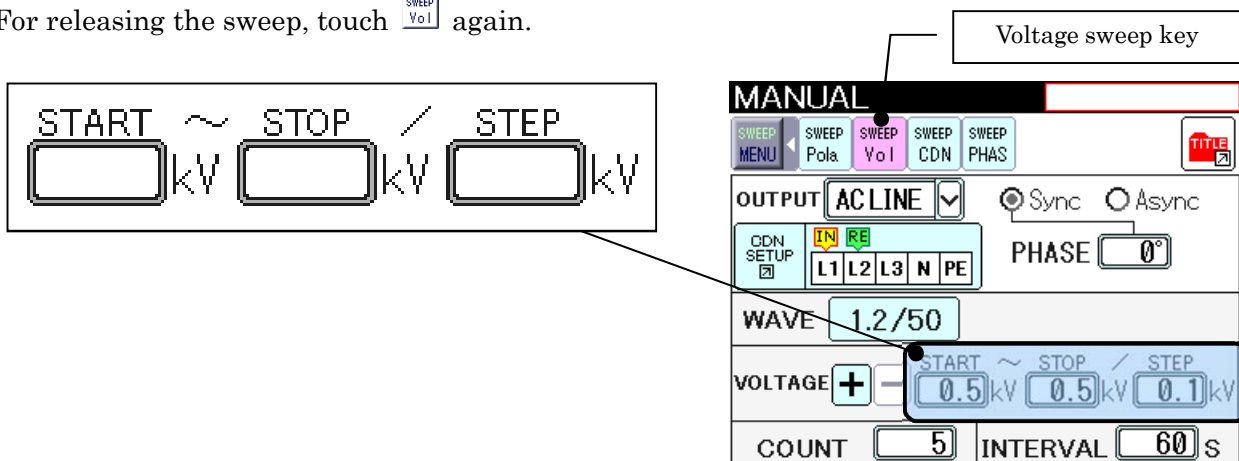

- The values are restricted as Starting value (START) ≤ Stopping value (STOP), Step value (STEP) ≥ 0.1.
- The settable voltage can be restricted up to 6kV on the utility screen. Refer to 15. UTILITY

Setting Discharge Times

Touch of COUNT to indicate the ten key. Input the discharge times and press Enter to fix the number of discharge times.

1~999 times 1 time step

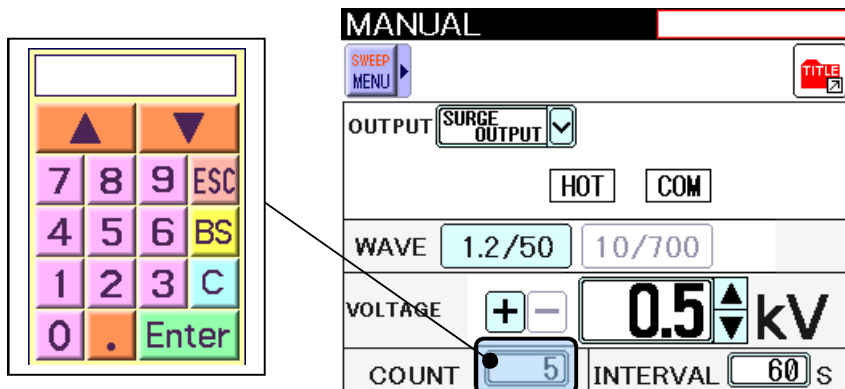

Setting Interval

Touch of INTERVAL to indicate the ten key. Input the value (unit: second) and press Enter to fix the value.

1.2/50 waveform selected

10~999s 1s step

Minimum value

4.0kV or less: 5 seconds

4.1kV or more: 10seconds

10/700 waveform selected

15~999s 1s step

Minimum value

4.0kV or less: 10 seconds

4.1kV or more: 15seconds

Ring wave selected

10~999s 1s step

Minimum value

4.0kV or less: 1seconds

4.1kVor more: 3seconds

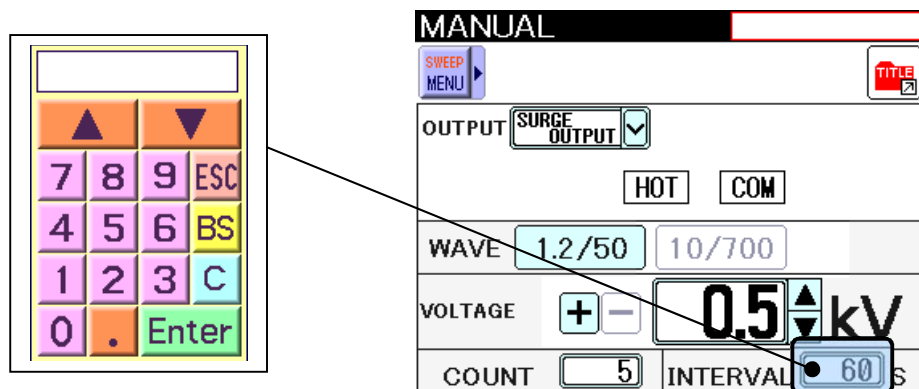

The first surge discharge after the test start is output when the minimum charging time (Only Ring wave is 3sec) has passed without any relationship with the set interval. After that, the Unit discharges surges with the set interval time.

13—2. Setting AC/DC Injection

In case of injecting surge to power lines, setting the injection phase and the return phase is necessary.

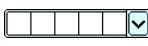

Touch  to move to the AC/DC CDN setup screen when AC LINE or DC LINE is selected on the manual setting screen.

 Touch  to select the presence or absence of the PE line.

Select the EUT line for the EUT. The indication of the injection phase and the return phase switches in accordance with the selected EUT line.

 Select the injection phase of the surge and touch the phase.

 Select the return phase of the surge and touch the phase.

 On the manual setting screen after returning there with pressing  on the CDN setup screen,  (the CDN setup display) indicates the CDN settings.

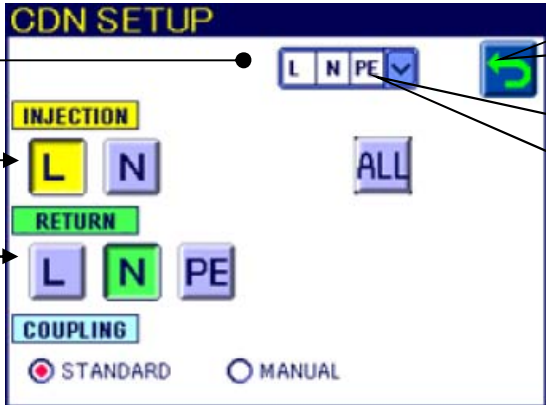

Indication of 『INJECTION』 and 『RETURN』 switches in accordance with the selected EUT line.

Used for returning to the manual setting screen from the CDN setup screen.

EUT line
Touch to select the presence or absence of the PE line



Selecting the same line as both of the injection and return phase is not available.







INJECTION 『ALL』 can be selected when presence of the PE in EUT line selection.
When 『ALL』 is selected, 『PE』 is selected for the return line.



- The test cannot start from this screen.
- Fully pay attention to connection of the line input and the line output.
 There should be no discrepancy between the actual connection and setting on the screen. Refer to 10. CONNECTION.

Injection phase sweep (AC/DC sweep)

If the CDN sweep key  is touched on the manual setting screen and  is touched, the screen moves to the CDN setup 'sweep' screen.

 Touch  to indicate the popup menu.

Select the EUT line for the EUT. All of the combinations of the injection phase and the return phase in accordance with the selected EUT line are displayed on the screen.

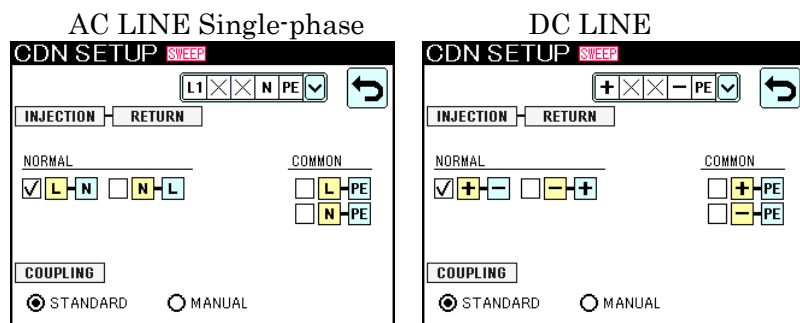





 Touch the combination of INJECTION-RETURN () to select the injection and return phase for the test.

If more than two combinations are selected, the sweep function works.



The order of sweeping is unchangeable.

L + N application cannot be combined.

 As for the order of sweeping, the normal mode is prioritized (NORMAL⇒COMMON). The injection phase takes the next priority. The order is L1⇒L2⇒L3⇒N, L⇒N, +⇒-.

 On the manual setting screen after returning there with pressing  on the CDN setup screen,  (the CDN setup display) indicates the CDN settings.

For releasing the sweep, touch  again.

-  • The test cannot start from this screen.
-  • Fully pay attention to connection of the line input and the line output.
 -  There should be no discrepancy between the actual connection and setting on the screen. Refer to 10. CONNECTION.

Setting coupling(1.2/50us-8/20us)

In the AC / DC injection setting, selecting the coupling circuit is available.

In the STANDARD mode, the coupling circuit which is prescribed on the IEC61000-4-5 is composed automatically. For the normal mode (line – line), it is fixed as $18\mu\text{F}$, for the common mode (line – PE), fixed as $10\Omega + 9\mu\text{F}$. Refer to the following schematics.

In the MANUAL test mode, the coupling circuit can be selected as $10\Omega + 9\mu\text{F}$ or $18\mu\text{F}$ with no relevance to the selected injection or return phase. Touch the item to be selected (●).

When "ALL" is selected, $10\Omega + 9\mu\text{F}$ is always used for each line regardless of the selection of MANUAL.

When 『STANDARD』 is selected

COUPLING

STANDARD MANUAL

When 『MANUAL』 is selected

COUPLING

STANDARD MANUAL

$10\Omega + 9\mu\text{F}$
 $18\mu\text{F}$

CDN SETUP

L1 N PE ↻

INJECTION

L
N

RETURN

L
N
PE

COUPLING

STANDARD
 MANUAL

Schematics on the STANDARD mode

AC single-phase and DC: Line - Line

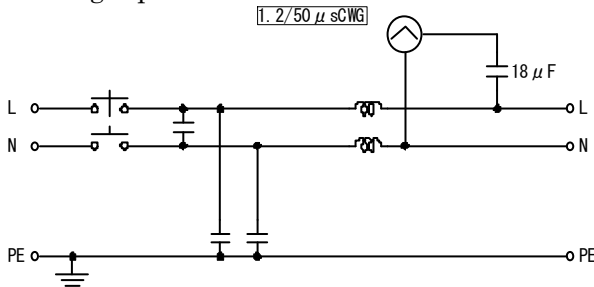

AC single-phase and DC: Line - PE

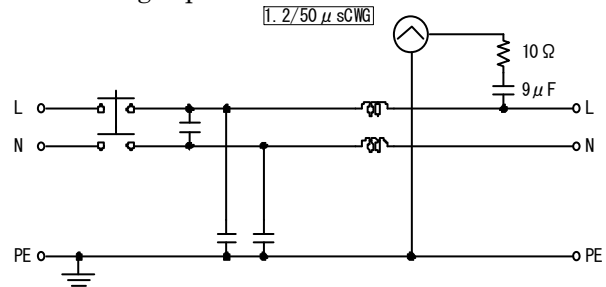

The default setting on shipment is as STANDARD.

Setting coupling (Ring waveform)

In the AC / DC injection setting, selecting the coupling circuit is available.

In the "STANDARD" mode, $4.5\mu\text{F}$ is inserted for each applied phase so that the coupling circuit $C \geq 3\mu\text{F}$ specified in IEC 61000-4-12. In the case of selecting RING waveform, "MANUAL" coupling cannot select

When "STANDARD" is selected

カップリング

STANDARD MANUAL

(When RING waveform is selected, MANUAL cannot select.)

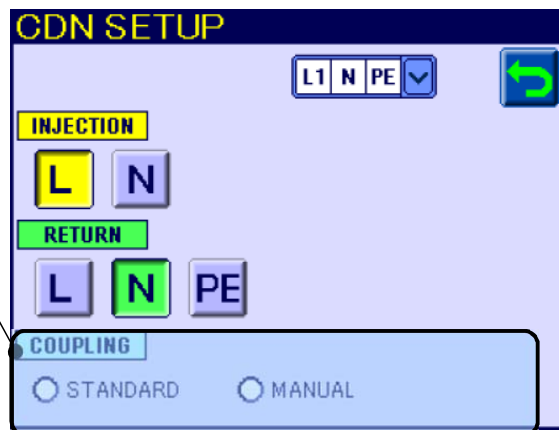
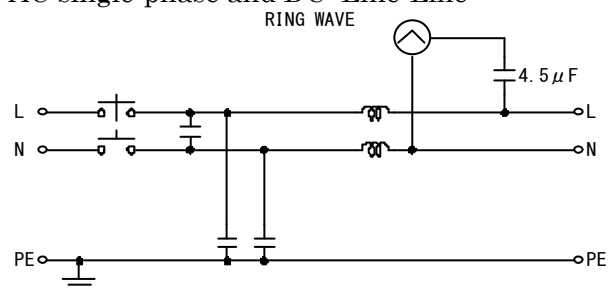

Diagram of coupling circuit for "STANDARD"

AC single-phase and DC: Line-Line



AC single-phase and DC: Line-PE

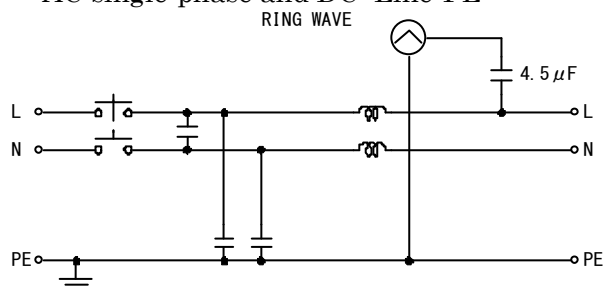
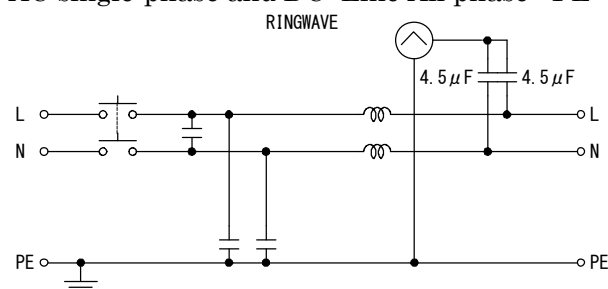
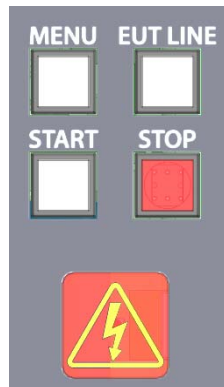

Diagram of coupling circuit for selecting "ALL"

AC single-phase and DC: Line All phase -PE



13-3.Executing Manual Test



- ① In case of the injection test to power lines, turn ON the line breaker of lines to be tested.
- ② Power supply to the EUT
 In case of the injection test to power lines, press the EUT LINE key [EUT LINE] to connect the line. The LED of the EUT LINE key illuminates when power is supplied.



Since the line power supply is output to the AC/DC line output terminal [AC/DC LINE OUTPUT] when the EUT LINE key is turned ON, fully be careful to the terminals for safety.

- ③ Check screen
 When the START key is pressed and settings of test conditions are complete, the following check screen is indicated. If there is any dissatisfied condition, an error message will appear. Confirm the whole condition and press the START key again to start the test. If [ESC] is pressed again on the check screen, the screen will return to the manual test setting screen.

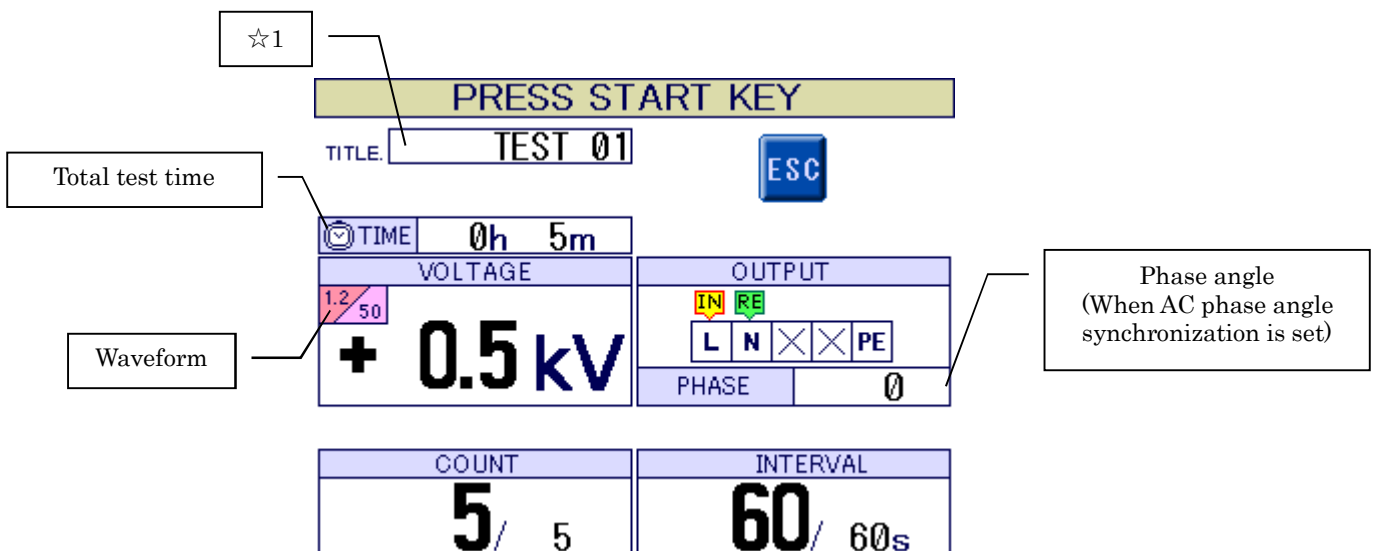

☆1 The title is indicated here when the test contents is saved.
 If the test contents are edited after saving, the title is not indicated.

Check screen when the sweep mode is set

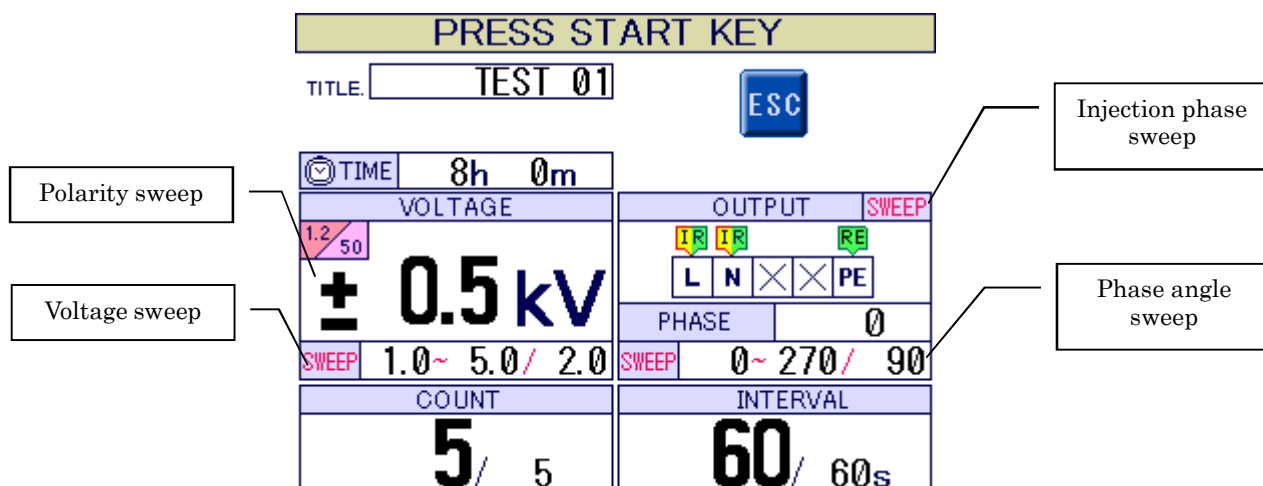

When SWEEP of voltage and/or phase angle is set, start value, stop value, and step value are indicated in the bottom column. When the injection phase sweep is set, 『SWEEP』 is indicated in the upper right column.

④ Conducting test

First, 『Test is being prepared』 is indicated. When switching the internal circuit is complete, 『UNDER TEST』 appears on the screen. The warning lamp is blinking while the test is conducted. The discharge times counts up and the interval counts down. Note that the minimum charging time^{※2} is counted down to the first surge output.

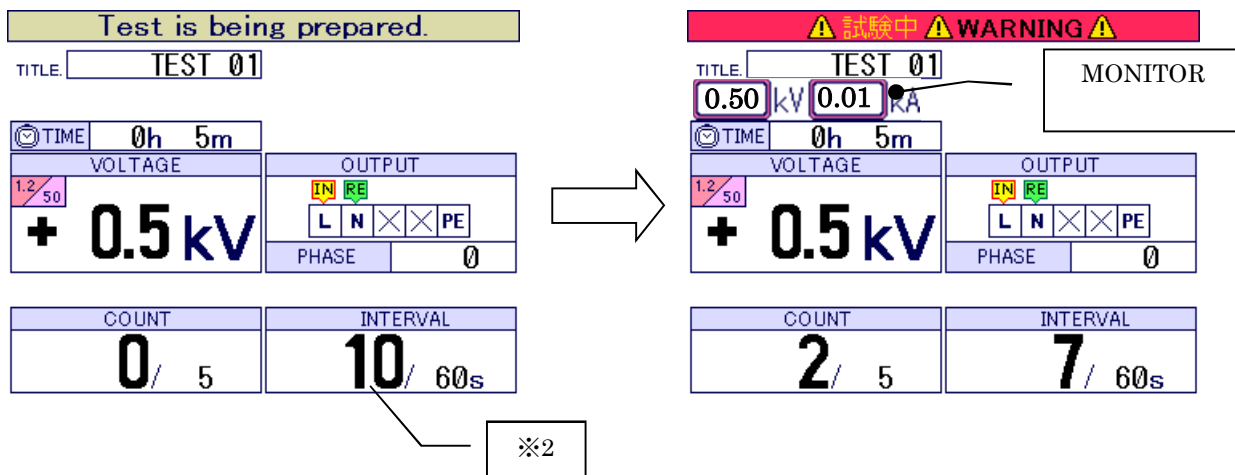

High voltage surges are output. Mishandling or careless operation may result in a fatal wound. Carefully handle it.

※2 The minimum charging time depends on the waveform and the output voltage. Refer to 『Setting Interval』 → P.47

⑤ Moving to the next test

If the sweep function is set and the sequence method on the “Utility” is “AUTO”, the test stage moves to the next automatically. If the sweep function is set and the sequence method on the “Utility” is “MANUAL”, 『Press START key to prepare next test』 is indicated, press the START key to start the next test.

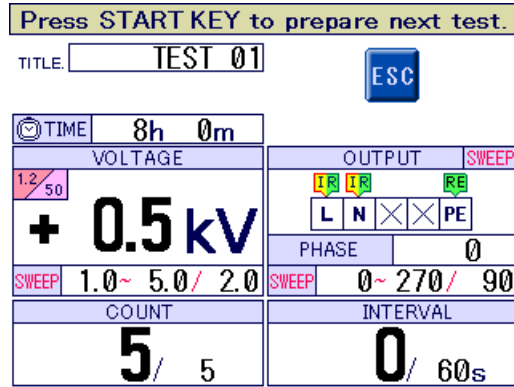

As for the sequence method, set it on the utility. Refer to 15. UTILITY.



In moving to the next test stage, ‘Pause’ is not available.

Pause

Pressing the START key while conducting test makes the output pausing. 『PAUSE』 is indicated on the screen. For restarting the test, press the START key again.

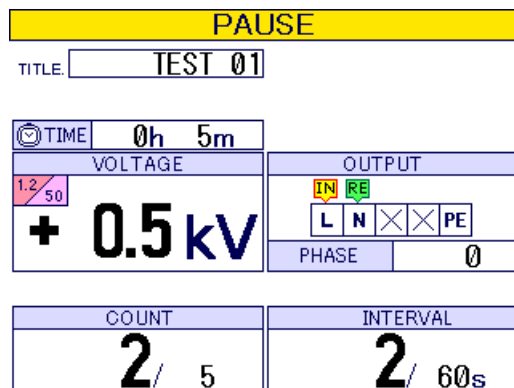

If 『PAUSE』 status is left as is for 10 minutes, the test will be stopped automatically for safety.

Suspension

Pressing the STOP key while conducting test makes the test stop at the moment. The START key lights off and 『Test suspended.』 is indicated on the screen.

☞ Confirming suspension, touch **OK** to return to the manual test setting screen.

Test suspended	
TITLE	TEST 01
OK	
TIME	0h 5m
VOLTAGE	OUTPUT
1.2/50	IN RE
+ 0.5 kV	L N X X PE
	PHASE 0
COUNT	INTERVAL
4 / 5	10 / 60s



Starting the test again on this screen is not available. For restarting, touch **OK** to return to the manual test setting screen and start again on that screen. Even if the test is suspended, the EUT line key is not turned OFF. For turning it OFF, manual operation is necessary.

⑥ Completion of test

The test is ended automatically when all of the set test is complete. The START key lights off and 『Test Completed.』 is indicated on the screen.

☞ Confirming completion, touch **OK** to return to the manual test setting screen.



Test Completed	
TITLE	TEST 01
OK	
TIME	0h 5m
VOLTAGE	OUTPUT
1.2/50	IN RE
+ 0.5 kV	L N X X PE
	PHASE 0
COUNT	INTERVAL
5 / 5	0 / 60s



- Starting test again on this screen is not available. For restarting, touch **OK** to return to the manual test setting screen and start again on that screen. When test is complete, the Unit provides a lag for eliminating electricity of the internal circuit. Elimination needs about 4 seconds. For safety, restarting is not available during that period.
- In case of conducting test with the EUT LINE key ON, when the LINE key is turned OFF, not only power supply is shut down, but also surge generation is stopped.
- When test is suspended or completed, the LINE key is not turned off automatically. Turn it off manually.

14. TITLE SAVE / LOAD





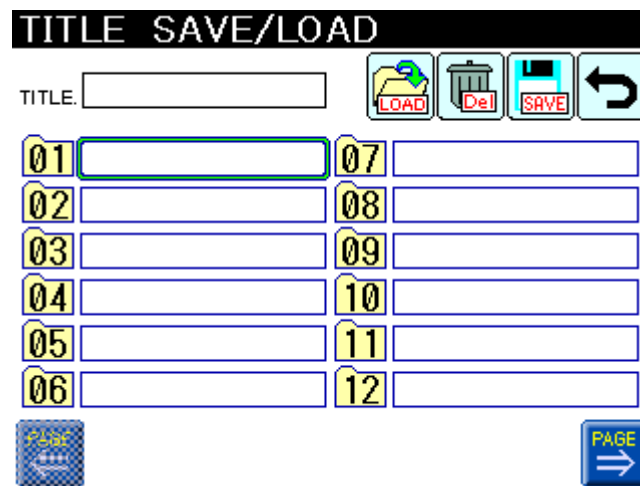

The test conditions set on the manual test setting screen can be saved with naming a title. Saving 36 kinds of sets is available and each title can include 12 or less roman letters, digits. Select a title box and select 『LOAD/DEL/ SAVE』 .

 Touch , upper right on the manual test setting screen or the sweep setting screen, or touch 『LOAD』 on the main menu to open the title operation screen.

Title operation screen



List of icons for operation

Icon of key	Remarks
	Title box to save a title. There are 36 pieces (12 pieces x 3 pages) of title boxes.
	Used for turning the page.
	Used for loading the saved titled file.
	Used for deleting the saved titled file.
	Used for saving / overwriting.
	Used for returning to the manual test setting screen and the sweep setting screen.



A test cannot start from this screen.

Save

☞ Touch a title box for saving and touch  to indicate character key. Input a title and fix it with Enter.

Ex.) Save a new file as TEST 01.

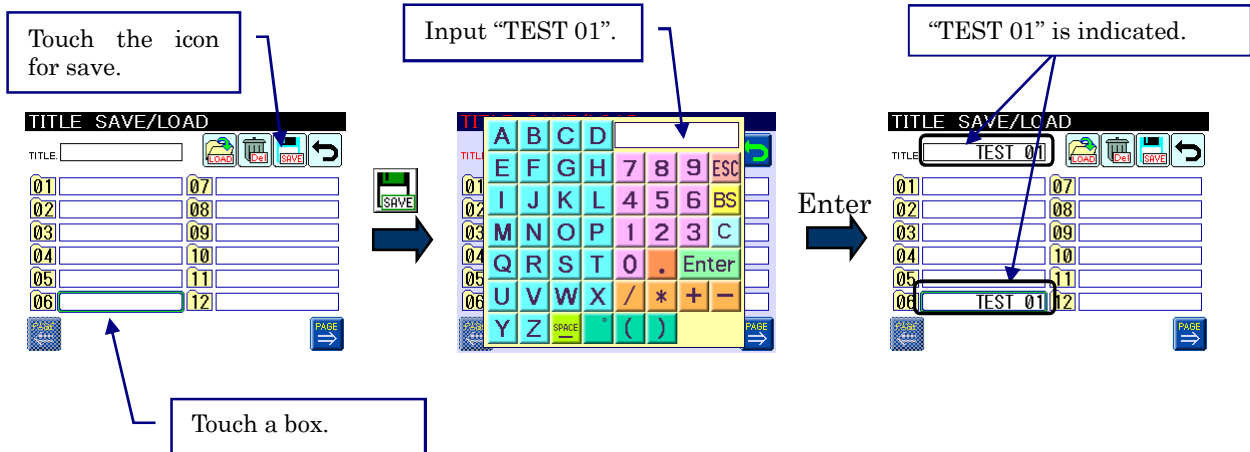

Overwriting

If you are trying to overwrite the already-saved file and save it, a check box appears. If 『OK』 is touched, the file is overwritten. In case overwriting is not necessary, touch 『CANCEL』.

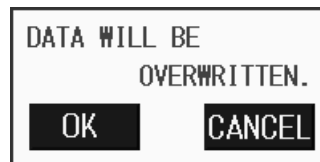

Changing Title

The title of the saved file can be changed.

☞ Touch a title box to be changed. → Touch the same box again to indicate character key.
→ Input a new title and fix it with Enter.



If Enter is pressed without inputting any letter, the title is saved as 『NO NAME』.





- For details of character key, refer to P.38.
- Title operation (save / delete) can be prohibited.
For details, Refer to 15.UTILITY "Title Operation" (P.69).

Load

Load means calling the saved titled file to use it for the manual test setting.

 Touch the title box to be called.

 Touch  to call the saved test contents.



If there is another set up in editing on the manual test setting screen, a check box as below appears before start loading. In case loading is not necessary, touch 『CANCEL』 .



Check box to confirm LOAD

Delete

 Touch the title box to be deleted.

 Touch  and a check box as below appears. Touch 『OK』 to delete, 『CANCEL』 not to delete.



Check box to confirm DELETE



Title operation (save / delete) can be prohibited.
For details, Refer to 15.UTILITY "Title Operation" (P.62).

15. UTILITY

Power ON Display

Selects the first screen indicated when the Unit is turned ON.

☞ Touch 『UTIL 1』 → 『POWER ON DISPLAY』 . Touch the check box (●) depending on your need.

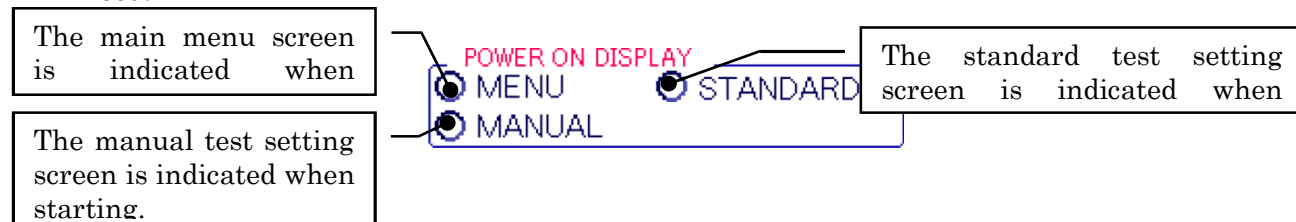

☞ 『MENU』 is selected as a default value on shipment.

Alarm BEEP

Selects whether an alarm sound beeps or not when handling the Unit.

☞ Touch 『UTIL 1』 → 『ALARM BEEP』 . Touch the check box (●) depending on your need.



☞ 『ON』 is selected as a default value on shipment.

Language

Selects language (English or Japanese) on the screen.

☞ Touch 『UTIL 1』 → 『LANGUAGE』 . Touch the check box (●) depending on your need.



☞ 『ENGLISH』 is selected as a default value on shipment.

EUT LINE Voltage Detection

Select ON/OFF the EUT LINE voltage detection function.

☞ Touch "UTIL 1" → "LINE CHECK". Touch the check box (●) depending on your need.



When voltage detection is set, EUT LINE cannot turn ON unless voltage is detected at EUT LINE INPUT. If no voltage is detected on the EUT LINE INPUT during the test, the test stops with an error. If no detection is set, EUT LINE can turn ON at any time.

☞ 『ON』 is selected as a default value on shipment.

External Trigger

Select EXT TRIGGER ON/OFF.

 Touch ON/OFF of EXTERNAL TRIGGER.



Surge can be output in synchronization with an external signal.

The trigger signal input method is below. The figure shows the input interface.

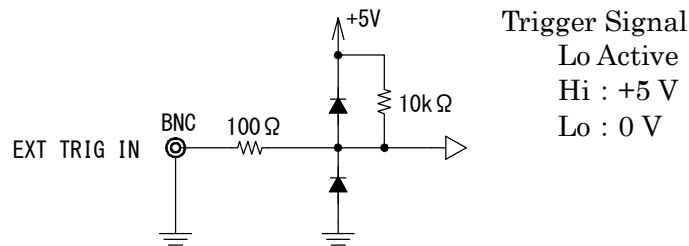

As the trigger input terminal is pulled up to +5 V internally, short-circuiting BNC connector for input can be a trigger signal.

When EXT TRIGGER is enabled, after the discharge interval becomes "0", "WAITING TRIGGER" is displayed and the unit enters the signal input standby state from [EXT TRIG IN].

A surge is output about 1 ms after Lo is recognized.

When the phase angle synchronization is set, it outputs at the first specified phase angle after 1 ms after recognizing Lo.

If there is no trigger input for more than 90 seconds in the "WAITING TRIGGER" state, the test stops.



『OFF』 is selected as a default value on shipment.

Interlock Level

Selects the way of turning OFF when the interlock is unlocked.

 Touch 『UTIL 2』 → 『INTERLOCK LEVEL』. Touch the check box (●) depending on your need.

Only the high voltage output is turned OFF. The EUT line is not turned OFF.

Both of the high voltage output and the EUT line are turned OFF.

INTERLOCK LEVEL

HIGT VOLTAGE OFF

HIGT VOLTAGE OFF + EUT LINE OFF



『HIGH VOLTAGE OFF + EUT LINE OFF』 is selected as a default value on shipment.

Sequence Method

Selects how to move to the next test stage. This function works when conducting the standard test and when the sweep function is set.

 Touch 『UTIL 2』 → 『STANDARD TEST MODE』. Touch the check box (●) depending on your need.

Pressing START key is necessary to move to the next test stage.

The test stage moves to the next automatically.

STANDARD TEST MODE

MANUAL AUTO



『MANUAL』 is selected as a default value on shipment.

Title Operation

On the title operation, operation of saving and deleting can be prohibited.

 Touch 『UTIL 2』 → 『TITLE OPERATION』. Touch the check box of 『PROHIBITED』 (●) if prohibition is necessary.

Save/Overwrite/Delete are prohibited.

TITLE OPERATION

PROHIBITED



『OFF』 is selected as a default value on shipment.

Phase Angle Correction

Selects automatic correction of the phase angle according to the selected line in the phase angle synchronization test. This setting is for manual testing only.

Refers to “16. Phase Angle Correction” for details.

Perform Phase Angle Correction

PHASE CORRECTION

USED NOT USED

Do not perform Phase Angle Correction



『USED』 is selected as a default value on shipment.

EUT FAIL Signal

Set the test processing method for the EUT FAIL function. Input channels 1 to 3 can set independently.

 Touch “UTIL 3” → “EUT FAIL INPUT”

Touch the check box () depending on you need.

“FAIL SIGNAL” : Select whether to enable / disable the EUT FAIL signal input.

“TEST STATE” : Selects test processing when an EUT FAIL signal is input.

When the FAIL signal is enabled (Enable), select whether to stop the test (STOP) or pause (PAUSE).

“EUT LINE” : Select the processing of the EUT line connection when the EUT FAIL signal is input.

When the CDN is used and the FAIL signal is enabled (Enable), select whether to keep the power on (KEEP) or forcibly shut off (OFF).

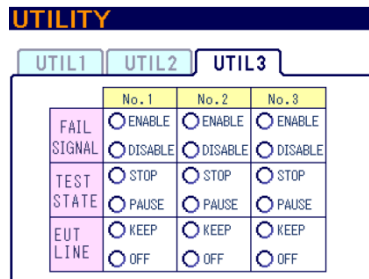

The EUT FAIL input interface is as below.

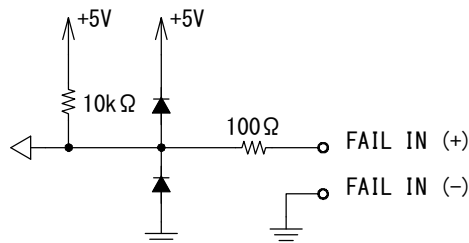

16. Phase Angle Correction

Phase correction in case of AC power line surge injection

This simulator is equipped with phase angle correction function for surge injection to AC power lines, capable of “USED” or “NOT USED” selection for the “Phase Correction” on the UTILITY setting display (refers to Chapter 15). In case the “NOT USED” is selected, surge is injection at the timing when the phase angle is set at the reference of zero-cross between L-N on single-phase lines, or between L1-L2 on three-phase lines, regardless of the surge injection line setting. In case the “USED” is selected, the phase angle correction is executed according to the surge application line setting. As a basic way of thinking of the phase angle correction, AC voltage waveform of the surge injection to specific power lines is automatically corrected to align with the phase angle setting on the display in order to make the positive-side top at 90° based on zero-cross transition from negative to positive as 0° , and the negative-side top at 270° based on zero-cross transition to negative as 180° .

Phase correction of three-phase AC power lines

In case of the phase angle to be set to AC lines in three-phase power line setting, phase correction is executed according to injection line setting. Correction values with reference between L1-L2, add by $+120^\circ$ between L2-L3, and by $+240^\circ$ between L3-L1. And add by $+30^\circ$ between L1-N, by $+150^\circ$ between L2-N, and by $+270^\circ$ between L3-N.

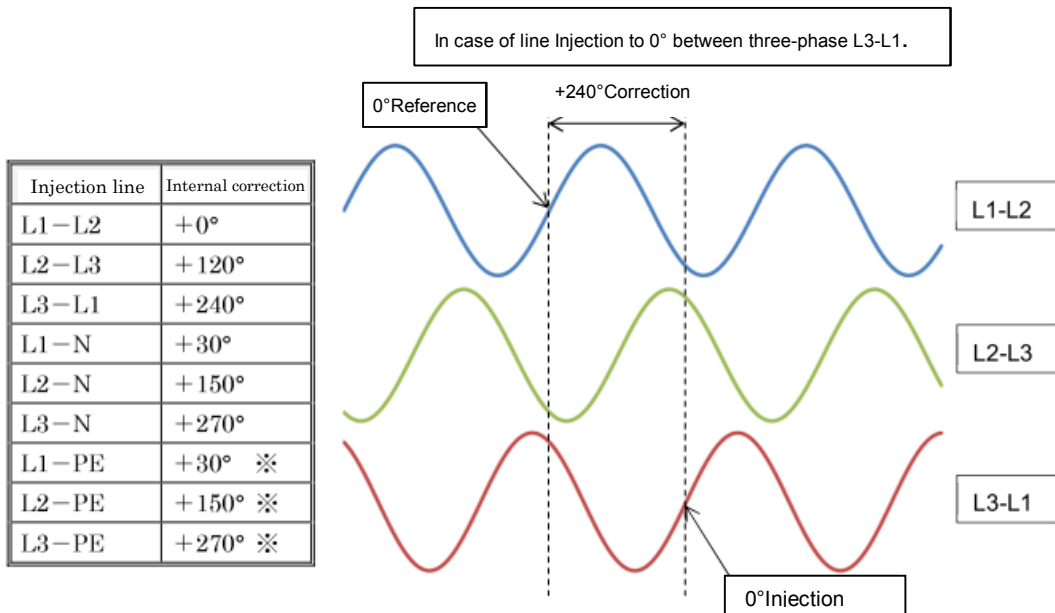

※: Theoretically, it is not possible to define the correction value in case of common mode Injection, as there are no phase relations between each power line phase and PE.

However, while performing actual testing, on connection path of in case of common mode Injection, as there are no phase relations between each power line r incorporated in the CDN unit inside the surge simulator is connected between each power line behind the insulation transformer and PE. This capacitor balances each power line phase, and makes the PE stay at the center point. And as the N phase is a center point as well, it is expected that the phase relation of the Line-PE to be equivalent to the Line-N.

After installing this simulator, observe the actual output, and confirm before testing whether the phase relationship between line-PE is equivalent to that between line-N or not.

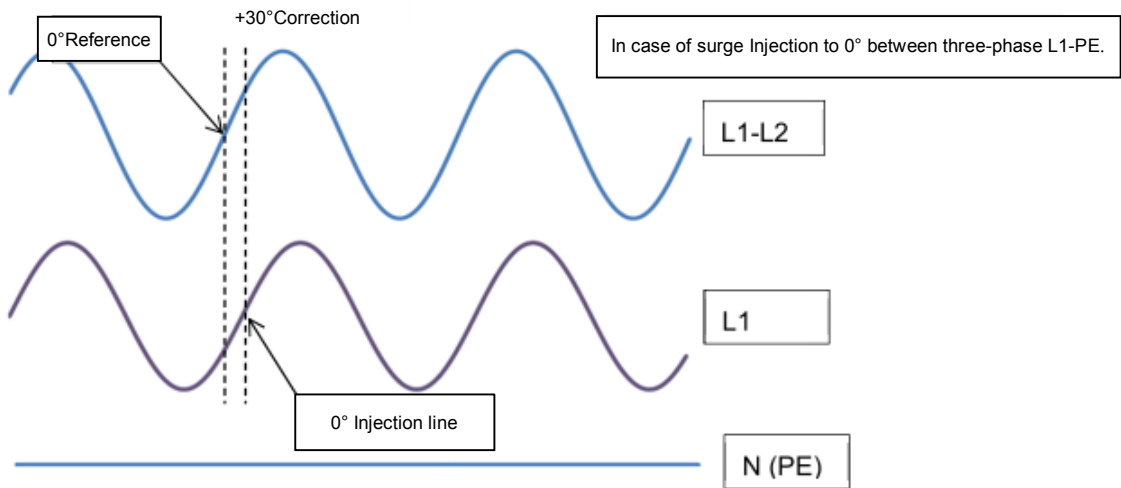

Phase correction of single-phase AC power lines

It is between L-N as a reference for AC line phase angle setting in case of single-phase power line setting. The correction is executed internally based on the phase reference between injection lines and return lines in single-phase testing as well.

In addition, because the PE line works as a center-point for the same reasons against the L & N as the three-phase setting (refers to previous page), the phase is reversed for injection between N-PE, and the correction executes as table below:

Injection line	Internal correction
L-N	+0°
L-PE	+0° ※
N-PE	+180° ※

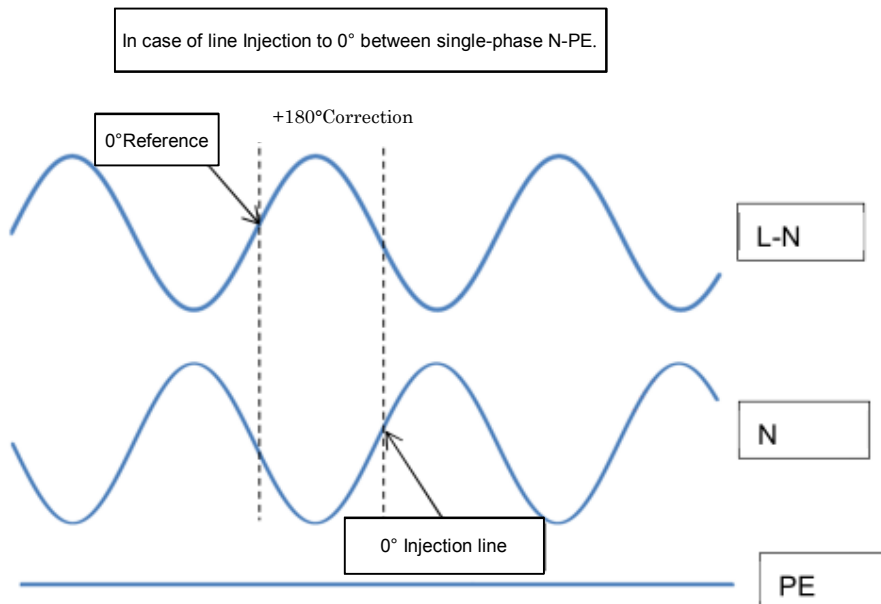

In the standard test, phase angle correction is always enabled.
 In the manual test, enable / disable can be selected by the utility setting.
 Refers to “Chapter UTILITY Phase Angle Correction P.61”

17. PRE CHECK

The pre-check function is to simply check whether the surge output is normally output from the output port. Recommend that you check the operation before conducting the test. This is not a self-calibration function of this tester.

For pre-check, use the Surge output confirmation cable (plug-plug cable 1m) and line output confirmation cable (plug-plug cable 1m) of the standard accessories.



Surge output confirmation cable
*Do not use plug-round crimp cable.

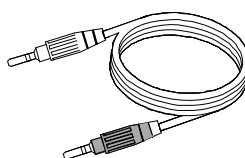

Line output confirmation cable

- ① Touch "PRE CHECK" from the main menu.
- ② Touch select the port to check.

【VOLT CHECK】 checks the surge voltage output of LSS-6330 by "surge out."

【CURRENT CHK】 checks the surge current output of LSS-6330 between "Surge out" and "L-N" "L-PE" "N-PE".

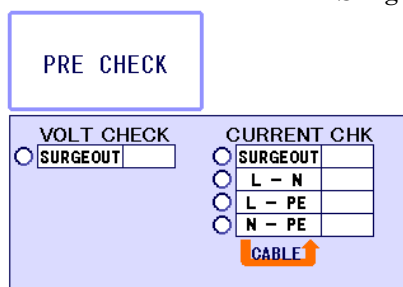

- ③ Cable connection and test
 - When the voltage surge check [VOLT CHECK], nothing is connected to the surge out output of LSS-6330.
 - When a current surge check [CURRENT CHK], connect the port to check with the attached cable.
 - In case of "Surge out", connect "Surge output confirmation cable" between "Surge out HOT/COM".
 - In case of "L-N" "L-PE" "N-PE"., connect the "line output confirmation cable" between the specified ports.
- At this time, the output confirmation cable should be placed so that it naturally hangs down without arranging it so as to make a large loop.

- ④ Press the START switch to execute the pre-check.
- In the case of "SURGE OUT", the output is set to 4kV. One time each time, "1.2/50 waveform"- "10/700 waveform"- "RING 12Ω"- "RING 30Ω" continuously output in order.
 - In the case of "L-N" the output setting voltage is 4kV, and the output phase is "1.2/50 waveform"- "RING 12Ω"- "RING 30Ω". Swap the applied phase & return phase and output again with the output setting voltage of 4kV, once in the order of "1.2/50 waveform"- "RING 12Ω"- "RING 30Ω".
 - In the case of "L-PE" and "N-PE", the output setting voltage is 4kV. One time each time, "1.2/50 waveform"- "RING 12Ω"- "RING 30Ω" continuously output in order.



Note that high voltage is output to the main unit and output cable during the pre-check. Incorrect or careless operation may cause serious injury.

⑤ Result

When the pre-check is executed, the result of each executed port is displayed. "PASS" as when each surge waveform is output normally, "FAIL" as when it is not output, and blank when not performed. For FAIL, check the cable connection status. If the cable connection is normal, there may be a problem with the surge output. Please contact our customer service center.



The pre-check result will be initialized to unexecute when returning to the menu screen.



The pre-check is to check the operation.
This operation does not guarantee output of the standard waveform.

◆Reference

The result of the pre-check refers to the monitor function.

When it is within, it is marked as "PASS";

in "VOLT CHECK", the voltage monitor value of each waveform is $4\text{kV} \pm 15\%$

in "CURRENT CHK", the current monitor value of each waveform is
 $(4\text{kV} \div \text{output impedance}) \pm 15\%$.

Output Impedance

Waveform	1.2/50	RING12	RING30	10/700
SURGE OUT	2 Ω	12 Ω	30 Ω	40 Ω
L-N	2 Ω	12 Ω	30 Ω	— (No output)
L-PE, N-PE	12 Ω	12 Ω	30 Ω	— (No output)

The impedance of the output cable may change significantly and the monitor value may not be within the specified value, if a cable other than the output confirmation cable is used at the output end, or if the cable is installed with a large lube.

18. ERROR MESSAGE

Errors indicated on the Unit are shown as below table.

Error message		Meanings
ERROR 1	Emergency stop check safety	Emergency stop button was pressed. The Unit cannot be operated. After confirming safety, turn on again.
ERROR 2	Fan error Repair is necessary	The fan does not work. Repair is necessary. Enquire of your sales agent or Noise Laboratory.
ERROR 3	Communication error of External CDN	Disconnected communication with the external CDN. Check that the power of the external CDN is not turned off, or if the optical communication cable is normal.
ERROR 4	External CDN error	External CDN response is invalid. Check the optical communication cable for any abnormalities. Check that the drive power of the external CDN is stable.
ERROR 5	EEP ROM error	An error has occurred in the internal EEPROM. Repair is necessary. Enquire of your sales agent or Noise Laboratory.
ERROR 6	Line input error A line cannot be detected	-The EUT LINE key was pressed without any line input. Check the line input. -The line input was not connected or the EUT LINE key was not turned ON in spite that line synchronization was set. Check the line input and the EUT LINE key. (Line input voltage: More than 10V is necessary)
ERROR 7	FAIL signal input *	A signal was input to the EUT FAIL of No. *. The test is the status set in UTILITY. Pay attention to high pressure because it may be PAUSE.
ERROR 8	Trigger timeout error	No signal was input to EXT TRIGGER. Waiting signal input for EXT TRIGGER, but the test was stopped because of no signalinput for 90 seconds.
ERROR 9	Interlock was released	Any of the following interlock is unlocked. -The interlock on the input panel -The arrestor cover on the telecom line injection panel
ERROR 10	Title name is Protected	Title operation was tried in spite that the operation is prohibited. Check setting of 『TITLE OPERATION』 on the utility screen.
ERROR 11	PC communication error	Communication error occurred during PC remote. Check the PC, communication module and optical communication cable for any abnormalities.

19. SPECIFICATIONS

19-1. General specifications

ITEM	SPECIFICATIONS	REMARKS
Communication	RS-232 optical communication	
Driving power supply	AC100V~AC240V $\pm 10\%$ 50Hz / 60Hz	
Consumption power	230 VA	
Operational environment	Temperature : 15~35°C Humidity : 25~75%RH	
Dimensions	W430×H349×D540 mm	
Mass	約 50kg	
Emergency stop	Push-lock type switch: Stops the test, turns OFF the high voltage generating part, and cuts OFF EUT line.	
Interlock function	For external connection equipment	Lock Release by shorting 1-3 pins
Warning lamp	LED start blinking when a test starts Color: Red	
Alarm connector	Available to connect the external warning lamp. The warning lamp starts illuminating when a test starts.	
EUT Fail	3 Channel	
Voltage monitor	BNC output: 2000V/V Accuracy : $\pm 10\%$ vs. actual ratio	Surge out setting *1 When output is open No waveform prescription
Current monitor	BNC output: 1000A/V Accuracy : $\pm 10\%$ vs. actual ratio	Surge out setting *1 When output is short-circuited No waveform prescription
Phase angle control	0° ~ 360° $\pm 10^\circ$	EUT power supply: More than AC90V Working at 50Hz/60Hz $\pm 10\%$
Trigger input	Asynchronized	Depending on repetition time
	AC line synchronized 0° ~ 360° / 1° step	For AC injection
	External input	TTL

*1 : Only voltage peak amplitude under open circuit conditions and current peak amplitude under short circuit conditions are guaranteed while no specifications are given with the EUT connected.

19—2. Surge Generating Part

ITEM	SPECIFICATIONS		REMARKS
1.2/50 μ s -8/20 μ s Combination waveforms	Open voltage	0.5kV~6.7kV \pm 10%	Cable length : One side 0.5m Voltage step: 0.1kV Setting available from 0kV
	Front time	1.2 μ s \pm 30%	
	Time to half-value	50 μ s \pm 20%	
	Short-circuited current	250A~3350A \pm 10%	
	Front time	8 μ s \pm 20%	
	Time to half-value	20 μ s \pm 20%	
10/700 μ s-5/320 μ s Combination waveforms	Open voltage	0.5kV~6.7kV \pm 10%	Cable length : One side 0.5m Setting available from 0kV
	Front time	10 μ s \pm 30%	
	Time to half-value	700 μ s \pm 20%	
	Short-circuited current	12.5A~167.5A \pm 10%	
	Front time	5 μ s \pm 20%	
	Time to half-value	320 μ s \pm 20%	
RING WAVE	Open voltage	0.25kV~6.6kV \pm 10%	Cable length : One side 0.5m Setting available from 0kV
	Voltage rise time	0.5 μ s \pm 30%	
	Ocillation frequency	100kHz \pm 10%	
	Decay	Pk2 = 40% < Pk1 < 110% Pk3 = 40% < Pk2 < 80% Pk4 = 40% < Pk3 < 80%	
	Short-circuited current	8.3~550A \pm 10%	
	Current rise time	0.2~1 μ s	
Output polarity	Positive / Negative		
Output impedance	2 Ω \pm 10%		1.2/50 μ s waveform
	40 Ω \pm 10%		10/700 μ s waveform
	12 Ω \pm 20%、30 Ω \pm 20%		RING (Selectable)
Generating circuit	Floating		
Minimum charging period	0.0kV -4.0kV : 5sec 4.1kV -6.7kV : 10sec		1.2/50 μ s waveform
	0.0kV -4.0kV : 10sec 4.1kV -6.7kV : 15sec		10/700 μ s waveform
	0.0kV -4.0kV : 1sec 4.1kV -6.6kV : 3sec		RING WAVE

19—3.AC / DC Line Injection Part

ITEM	SPECIFICATIONS		REMARKS	
Injection surge waveform	1.2/50 μ s -8/20 μ s Combination waveforms RING WAVE			
1.2/50 μ s -8/20 μ s Combination waveforms	Open voltage	0.5kV~6.7kV \pm 10%	Coupling circuit : 18 μ F Cable length : One side 0.5m Setting available from 0kV Line input side open	
	Front time	1.2 μ s \pm 30%		
	Time to half-value	50 μ s \pm 20%		
	Short-circuited current	250A~3350A \pm 10%		
	Front time	8 μ s \pm 20%		
	Time to half-value	20 μ s \pm 20%		
	Open voltage	0.5kV~6.7kV \pm 10%	Coupling circuit : 10 Ω +9 μ F Cable length : One side 0.5m Setting available from 0kV Line input side open	
	Front time	1.2 μ s \pm 30%		
	Time to half-value	50 μ s +10 μ s /-25 μ s		
	Short-circuited current	41.6A~558A \pm 10%		
	Front time	2.5 μ s \pm 30%		
	Time to half-value	25 μ s \pm 30%		
	RING WAVE	Open voltage	0.25kV~6.6kV \pm 10%	Coupling circuit : 4.5 μ F Cable length : One side 0.5m Line input side open
		Voltage rise time	0.5 μ s \pm 30%	
Ocillation frequency		100kHz \pm 10%		
Decay		Pk2 = 40% < Pk1 < 110% Pk3 = 40% < Pk2 < 80% Pk4 = 40% < Pk3 < 80%		
Short-circuited current		8.3~550A \pm 10%		
Current rise time		0.2~1 μ s		
Power capacity for EUT line	AC240V/20A MAX 50/60Hz DC125V/20A MAX			
Decoupling coil	1.5mH			
Voltage fall	Less than 10% of the rated voltage with the rated current flowing		At the output terminal of the AC injection part *2	
Residual voltage	Less than 15% of the injected voltage or less than double of the rated voltage (peak value)			

*2 : : verified with loading of 10 ohm resistive load and 4 ohm resistive load, with input of AC 200V

20. OPTIONAL PRODUCT

Major optional products are as follows.

For details, enquire Noise Laboratory or your nearest sales agent of Noise Laboratory

品 名	型 名	説 明
Warning light	11-00008B	Light rotating while testing for warning
Tri-color pilot light	11-00015A	Pilot light announcing the simulator status widely over the test area by three different colors illumination
Isolation transformer	TF-2302P TF-6503P	For isolation of line input. Single-phase AC240V/30A (TF-2302P) Three-phase AC600V/50A (TF-6503P)
Protective Safety Fence	11-00010A	Enable to materialize the safe test environment with connection to interlock function equipped in the simulator. The safety measure can be sure together with the EUT protective safety box.
EUT Protective Safety Box	11-00005A/6A	Protection box to prevent access to EUT during the test. Further safety is secured together with the protective safety fence.
Remote Software		Application software for remote-controlling the Unit from PC.
Optical USB Module	07-00022A	Connection adaptor for PC remote control of the simulator. USB optical conversion, equipped with 5m optical fiber cable.

21. WAVEFORM VERIFICATION

This chapter describes how to verify the output waveform of this simulator.

21-1. Preparation

- Oscilloscope (Frequency range: DC~100MHz or more)
- Isolation transformer

21-2. Connection

Connect voltage surge monitor terminal **【MONITOR OUTPUT V 1/2000】** or current surge monitor terminal **【MONITOR OUTPUT A 1/1000】** to the oscilloscope with the supplied coaxial cable. Input impedance of oscilloscope is set in advance for accurate observation at $1M\Omega$. Both of the voltage monitor circuit and the current monitor circuit are isolated from the surge generating circuit. As the electric potential of GND of the monitor terminal is common with the chassis of this unit, safety is secured.

How to observe at Monitor Terminal

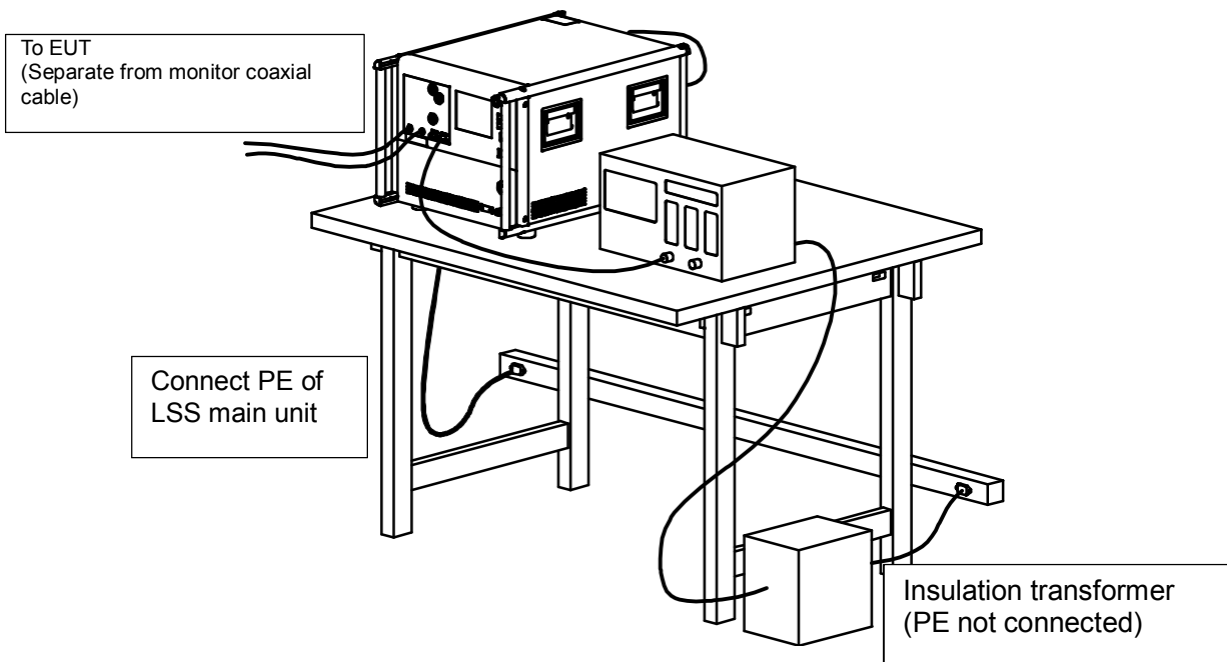

Fig 20.1 How to observe waveform

21 – 3.Measurement

Set the probe input $1M\Omega$ on the oscilloscope and the ratio at 1:1. Set the voltage axis and time axis of the oscilloscope according to surge voltage (current) output. As monitor output ratio is VOLTAGE: 1/2000, CURRENT: 1000A/V, when surge voltage is 15kV, voltage monitor output is 7.5V, and when surge current is 7500A, voltage monitor output is 3.3V. As for time axis, set at $20\mu\text{s}/\text{DIV}$ to observe the entire waveform.

As the purpose of the monitor terminal is to observe waveform easily without any special probe, it cannot provide observation of great precision. And, besides, as both voltage and current are detected at the surge output terminal, in case of injection out especially, actual waveform to EUT via the injection part and cables is sometimes different form observed ones.



As the surge generating circuit of this unit is floated, if you try to observe output waveform directly via a high voltage probe, you may receive an electric shock, or measurement instruments may be damaged. Never do so. If you need to observe waveform directly, contact Noise laboratory.

21 – 4.Why PE of Oscilloscope Should Not be Common with Earth of the Unit

A strong magnetic field generates on an output route by the surge current. If a closed circuit is made via common GND between the monitor terminal and the oscilloscope, an induced electromotive force will generate as the figure as the below shows. As a result, since the difference of electric potential between the monitor terminal GND and the oscilloscope GND occurs, measurement error will be bigger. To prevent this phenomenon, a closed circuit between this unit and the oscilloscope should be avoided.

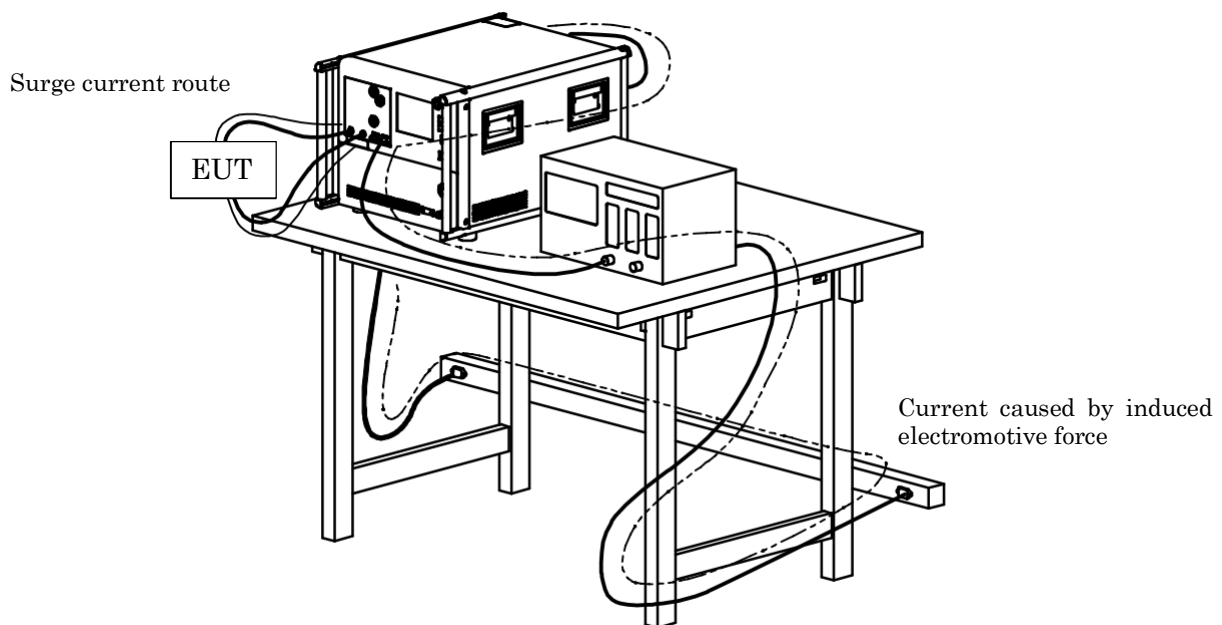

Fig .20-2 Bad Example: Without the isolation transformer--Measurement error might be bigger.

22. WARRANTY

Services

The following terms are applicable to the services provided by the Company to maintain and repair the Unit.

1. Scope

The Unit and accessories and options provided by the Company are covered under this section.

2. Technical Service Fee

Any repairs provided by the Company during the warranty period will be free of charge in accordance with the Limited Warranty. After expiration of the warranty period, actual cost for the repair will be charged to the user.

3. Ownership of Defective Parts

All the defective parts replaced during the warranty period become the property of the Company. For paid repairs, they also become the property of the Company unless otherwise directed by the user.

4. Maximum Compensation

In the event the user incurs damage due to malfunction of the Unit arising solely from the negligence and/or improper repair on the part of the Company, the Company will compensate for the damage. The maximum compensation amount shall be limited to the amount paid by the user at the time of purchase of the Unit. In no event, shall the company be liable or in any way responsible for incidental or consequential damages such as loss of profit or third party's claims to the user.

5. Wrong Parts, Missing Parts and Damage

The company shall not be liable for loss of profit, business interruption, other incidental damage, special loss, punitive damage or third party's claims to the user directly or indirectly arising from suspension of testing activities due to wrong parts, missing parts, or damage of the Unit.

6. Service Refusal

The company may not accept a repair order in the following cases:

- More than 5 years have passed since the product discontinued
- More than 8 years have passed after delivery
- Required component for servicing already discontinued and no alternative is available.
- Product changed, repaired or remodeled without obtaining a prior permission from the Company.
- Product severely damaged to the extent it has lost its original form

Limited Warranty

In the event of failure during the warranty period, the Unit will be repaired or replaced free of charge. Decision of the repair method shall be left at the discretion of the Company. This limited warranty is applicable in Japan only.

1. Scope

This warranty is applicable only to the Unit and its accessories.

2. Warranty Period

One year from the date of delivery.

For a location once repaired, the warranty period for same parts / same problems is 6 months from the time of repair completion.

3. Exceptions

Regardless of the above, following will be excluded from the warranty.

- ◇ Consumable parts replacement, including High Voltage Relay (if used)
- ◇ Failure caused by negligence, or damage to the Unit.
- ◇ Failure due to modifications made without the Company's authorization.
- ◇ Failure due to repairs made by personnel not authorized by the Company.
- ◇ Failure directly or indirectly arising from force majeure including but not limited to, acts of god, fire, war, rebellion and others.
- ◇ Failure due to shipping, vibration, falling, or impact shock after delivery
- ◇ Failures due to use of the Unit under the improper environment.
- ◇ When the Unit is taken out of the country.

23. MAINTENANCE

1. When repair, maintenance or internal adjustment of the Unit is required, a qualified service engineer takes charge of such work.
2. Maintenance on the user side is restricted to the outside cleaning and functional check of the Unit.
3. When checking or replacing the fuse, turn off the switch of the Unit and disconnect the plug socket beforehand.
4. When cleaning the Unit, turn off the switch of the Unit and the connected equipment and disconnect the plug socket beforehand.
5. Avoid using chemicals for cleaning. Otherwise, the coating of the Unit may peel off or the sight glass may be broken.
6. Do not open the cover of the Unit.

24. NOISE LABORATORY SUPPORT NETWORK

- If a symptom which seems a trouble is found, inform the model name and serial number of the product together with the symptom to Noise Laboratory or your nearest sales agent of Noise Laboratory.

When the product is returned to Noise Laboratory, write the state of the trouble, contents of your request, model name and serial number in a repair order, and pack the product and repair order sheet in the former package of equivalent suitable for transit and send them back.

NOISE LABORATORY CO., LTD.

1-4-4, Chiyoda, Chuo-ku, Sagamihara City, Kanagawa Pref., 252-0237, Japan

TEL: +81-(0)42-712-2051 FAX: +81-(0)42-712-2050

URL: <http://www.noiseken.co.jp>

Printed in Japan