

INSTRUCTION MANUAL

ELECTROSTATIC DISCHARGE SIMULATOR

MODEL ESS-B3011

- Thank you very much for your purchasing this instrument.
- This instrument generates high voltage.
Since failure to follow instructions for handling this instrument may cause an electric shock or other kinds of accidents, please be careful for safety in handling this instrument.
- Please read this booklet carefully, understand its content well to use this instrument safely and properly, and keep it by your side or other proper location so that it may be always readily available.

NOISE LABORATORY CO., LTD.

NOTICE

- No part of this booklet may be reproduced or transferred, in any form, for any purpose, without the permission of Noise Laboratory Co., Ltd.
- The contents of this booklet have been thoroughly checked. However, if a doubtful point, an error in writing or a missing is found, please contact us. → See **21.CONTACTING TECHNICAL SUPPORT.**
- Noise Laboratory Co., Ltd. shall have no liability for any trouble resulting from the misuse or improper handling of this product regardless of the contents of this booklet or arising from the repair or remodeling of this product by a third party other than Noise Laboratory Co., Ltd. or its authorized person.
- Noise Laboratory Co., Ltd. shall have no liability for any trouble resulting from the remodeling or modification of this product.
- In no event shall Noise Laboratory Co., Ltd. be liable for any results arising from the use of this product.
- Trademarks, company names, and similar that appear in this document are trademarks or registered trademarks of their respective companies. This document does not use the TM and ® symbols.

1. IMPORTANT SAFETY PRECAUTIONS

The "Important Safety Precautions" explain rules that must be followed to prevent any risk of harm or injury to the user of the instrument or to other people.

- **The instrument may only be used by trained EMC technicians (electrical technicians)**

Failure to follow this rule risks death or serious injury.

- **The instrument may not be used by people fitted with electronic medical devices such as pacemakers and such people may not enter the testing site while the instrument is operating**

The medical device may malfunction since the instrument emits more electromagnetic wave than the regulated value.

- **Do not use the instrument for any purposes other than the EMC testing purposes described in this instruction manual.**

The instrument is not supposed to be used in manufacturing process of a factory.

- **The instrument may not be used in a location where fire is prohibited or there is a risk of explosion**

Failure to follow this rule risks igniting a fire due to an electrical discharge.

- **The supplied AC power cable of the instrument is intended only for Japan and North America.**

In case of using the instrument in other countries than the above, use an AC power cable that is certified for use under the safety rules of the country in which the instrument is being used.

Before setting up the test site, connecting the equipment, or starting testing, please read the Chapter entitled "Basic Safety Precautions for the Safe Use of the Simulator" which contains additional safety advice.

2. CHECK PACKAGE CONTENTS

Before using the instrument, please check that none of the main unit and associated items are missing.



Item	Quantity
A: Main unit.....	1
B: AC power cable.....	1
C: Instruction Manual (this document)	1

3. APPLICATION FORM FOR INSTRUCTION MANUAL

To: Noise Laboratory Co., Ltd. via sales agent

We place an order for an instruction manual.

Model Name

Serial No.

Applicant Address _____

Company Name _____
Department _____
Contact Person _____
Phone No. _____
FAX No. _____

Cut Line

Cut off this page "**PURCHASE ORDER FOR INSTRUCTION MANUAL**" from this volume and **keep it for future use with care.**

When an INSTRUCTION MANUAL is required, fill in the above Application Form and mail or fax it to your nearest sales agent of Noise Laboratory or Noise Laboratory.

Cut Line

The address, company name, individual's name, and other personal information (henceforth referred to as "personal information") entered in the application form will only be used for the purpose of sending the Instruction Manual and will not be shown or passed to any third party without a valid reason. Noise Laboratory Co., Ltd. will manage customer's personal information in an appropriate manner.

4. TABLE OF CONTENTS

1. IMPORTANT SAFETY PRECAUTIONS	1
2. CHECK PACKAGE CONTENTS	2
3. APPLICATION FORM FOR INSTRUCTION MANUAL	3
4. TABLE OF CONTENTS	5
5. PREFACE	8
5-1. Features	8
5-2. Function Restrictions and Compliance Standards by Combinations with Discharge Gun	9
6. BASIC SAFETY PRECAUTIONS FOR THE SAFE USE OF THE SIMULATOR ..	10
6-1. Meaning of Safety Symbols	10
6-2. DANGER Alerts	12
6-3. WARNING Alerts	12
6-4. CAUTION Alerts	14
7. POINTS TO NOTE REGARDING CONSUMABLES ITEMS	16
8. INTRODUCTION	17
8-1. How to Read This Document	17
8-2. Terms and Definitions	18
9. NAME AND FUNCTION OF EACH PART	19
9-1. Main Unit (Front Panel)	19
9-2. Main Unit (Rear Panel)	20
9-3. Operation Switch Section	21
10. BASIC TEST FLOW	24
11. DEVICE CONNECTIONS	27
11-1. Connecting the Discharge Gun	27
11-2. Connecting the AC Power Cable	28
12. OPERATION	29
12-1. Turning the Power On or Off	29
12-2. Test Condition Settings	29
12-3. Setting Basic Items	30
1) <i>Setting the polarity</i>	30
2) <i>Setting the voltage, discharge interval and discharge count</i>	30
12-4. Setting Test Mode	31
1) <i>Changing between contact and air discharge</i>	31
2) <i>Setting the trigger</i>	31
3) <i>Setting the radiation level</i>	32
12-5. How to Set Special Functions	33
1) <i>Setting the IEC level</i>	33
2) <i>Setting the gun light</i>	34
3) <i>Discharge detection function</i>	34

4)	<i>Performing the pre-check</i>	35
12-6.	Performing a Test	36
1)	<i>Starting a Test</i>	36
2)	<i>Stopping a Test</i>	37
13.	RADIATION LEVEL MODE	38
13-1.	Radiation Noise	38
13-2.	Differences between Radiation Level Modes	38
13-3.	How to Set the Radiation Level Modes.....	39
14.	AUTOMATIC CR UNIT & DISCHARGE CUP RECOGNITION FUNCTION	40
14-1.	Operation of Automatic Recognition Function	40
14-2.	Determining CR Unit.....	41
14-3.	Determining Discharge Cup.....	41
15.	PRE CHECK	42
15-1.	Performing the Pre-check.....	42
15-2.	Displaying the Result.....	42
15-3.	ERROR Causes and Solutions.....	43
16.	BACKGROUND KNOWLEDGE ABOUT ELECTROSTATIC TESTING	44
17.	ERROR DISPLAY	46
18.	SPECIFICATIONS	47
19.	WARRANTY	48
20.	MAINTENANCE	50
21.	CONTACTING TECHNICAL SUPPORT	51

5. PREFACE

We thank you very much for your purchase of the Computer-controlled Electrostatic Discharge Simulator Model: ESS-B3011. It is recommended that the contents of this manual be thoroughly understood and used as a ready reference for operation.

-
- **This Instruction Manual was prepared so that any person who can observe the prescribed instruction method and operating precautions may safely handle and fully utilize this computer-controlled electrostatic simulator (Model ESS-B3011).**
 - **For ESD testing, the discharge gun (sold separately) is necessary. The complied standards depend on the connected discharge gun. → See 5-2. Function Restrictions and Compliance Standards by Combinations with Discharge Gun.**
 - **Keep this Instruction Manual by your side or other proper location so that it may be readily available when using the ESS-B3011.**
-

5-1. Features

Compliant with IEC 61000-4-2 (Edition 2.0 2008)

- The electrostatic discharge immunity test defined in IEC 61000-4-2 (Edition 2.0 2008) can be performed by connecting the optionally available electrostatic discharge gun GT-30R.
- NoiseKen's existing discharge gun TC-815R,TC-815S can also be connected.

Compliant with ISO 10605 (2nd Edition 2008)

- The electrostatic discharge immunity test defined in ISO 10605 (2nd Edition 2008) can be performed by attaching the accessory specified by NoiseKen to the optionally available electrostatic discharge gun GT-30R.
- NoiseKen's existing discharge gun TC-815-330/2k,TC-815S-330/2k can also be connected.

Highly operable front panel

- Sloping front panel provides easy operation even when placed on the floor.
- The rotary knob allows the user to set test conditions with ease.

Convenient functions to support testing

- The **【IEC LEVEL】** key enables the test levels specified in the IEC standard to be set with a single keystroke.
- A discharge detection function is provided to detect the actual discharge and notify the user (in air discharge mode only).
- A pre-check function is provided to enable operational inspection prior to the test.
- An automatic recognition function is provided to prevent an erroneous combination of the CR unit and discharge cup.

Notice

The fonts, layout, and similar in the screens shown in this manual may differ from the actual screens and parts of actual screens may be omitted. Also, some screens have been changed to make them clearer to understand in the printed manual.

5-2. Function Restrictions and Compliance Standards by Combinations with Discharge Gun

This instrument is a power supply/control unit used to perform electrostatic tests. The standard with which it complies differs depending on the discharge gun used in the combination with it.

Also, the requirements for the CR value and discharge current waveform vary, depending on the standard. To comply with each standard, an optionally available CR unit and discharge cup must be combined appropriately.

The following table shows the compliant standard for each discharge gun model.

○: Standard complied with in its normal configuration

△: Standard that can be complied with by using an optionally available CR unit and discharge cup

×: Standard that cannot be complied with even by combining optionally available components

Discharge gun model		IEC 61000-4-2		ISO 10605		Functional restriction on this instrument
		1.2	2.0	1 st	2 nd	
Current Model	GT-30R	○	○	△	△	No functional restrictions
	GT-30R330	○	○	△	○	
	GT-30R2K	△	△	○	○	
Previous Model	TC-815P	○	○	×	×	The following functions are not available. <ul style="list-style-type: none"> ▪ Discharge detection ▪ Pre-check ▪ Discharge gun LED light ▪ CR & cup combination recognition
	TC-815R	○	○	△	×	
	TC-815S	○	○	△	×	
	TC-815ISO	△	△	○	×	
	TC-815-330	×	○	△	○	
	TC-815S-330	×	○	△	○	
	TC-815-2k	×	△	○	○	
TC-815S-2k	×	△	○	○		

※Complied standard in inspection on shipment

When this simulator is shipped out, it is inspected with the standard indicated as below depending on the discharge gun which is shipped with the simulator.



Discharge gun model	Complied standard in inspection on shipment
GT-30R	IEC 61000-4-2 Ed.2
GT-30R330	ISO 10605 2nd
GT-30R2K	ISO 10605 2nd

6. BASIC SAFETY PRECAUTIONS FOR THE SAFE USE OF THE SIMULATOR











- The "Basic Safety Precautions" explain rules that must be followed to prevent damage to property or injury to the user of the instrument or to other people.
- The symbols below are used to indicate the level of injury or damage that may result if the instrument is used in a way that ignores these precautions. Please take careful note of the meanings of these symbols before proceeding to read this manual.

6-1. Meaning of Safety Symbols





- ◆ The following symbols indicate the level of injury or damage that may result if the instrument is used incorrectly in a way that ignores the associated precautions.

 DANGER	<p>This symbol indicates that failure to comply with the associated precaution "is highly likely to result in the risk of death or serious injury".</p>
 WARNING	<p>This symbol indicates that failure to comply with the associated precaution "may result in death or serious injury".</p>
 CAUTION	<p>This symbol indicates that failure to comply with the associated precaution "may result in damage but that only physical damage is likely to occur".</p>

- ◆ The following symbols indicate the nature of the associated precaution.

	<p>Indicates a warning (a situation where caution is required).</p>		
	<p>Indicates a prohibition (an action that is not allowed to occur).</p>	 Prohibited	 Disassembly Prohibited
	<p>Indicates an instruction (an action that must always be taken).</p>	 Safety Rule	 Always earth correctly
		 Unplug from Mains Power	

- ◆ The following symbols indicate the nature of the associated warnings or cautions that relate to the use of the instrument.

	<p>Indicates a risk of electric shock.</p>
	<p>Indicates that caution is required and that you should refer to the instruction manual.</p>
	<p>Indicates a warning, a risk of electric shock, that caution is required, and that you should refer to the instruction manual.</p>
 <p>WARNING TO REDUCE THE RISK OF ELECTRIC SHOCK. DO NOT REMOVE COVER. NO USER-SERVICEABLE PARTS INSIDE. REFER SERVICING TO QUALIFIED SERVICE PERSONNEL. 感電の危険あり。カバーを外さないこと。</p>	<p>Indicates a warning, a risk of electric shock, that caution is required, and that you should refer to the instruction manual.</p> <p>Warning text Do not remove the cover because of the risk of electric shock.</p>
<p>NOISE LABORATORY CO.,LTD. IS EXCLUDED ALL THE LIABILITY OF ANY FORMS OF DAMAGE, OF EQUIPMENT OR HUMANS, CAUSED BY USER'S MISHANDLING DURING OPERATION. 誤った操作による損害に対しては、一切責任を負いません。</p>	<p>Warning relating to the use of the instrument Noise Laboratory Co., Ltd. accepts no liability for damage resulting from misuse of the instrument.</p>

6-2. DANGER Alerts



Disassembly
Prohibited

- **Do not disassemble or modify
Do not remove the cover**

Failure to comply with the precaution may result in death or serious injury and possible consequences include fire and electric shock.

For inspection or repair of internal components, please contact your sales agent or the Noise Laboratory repair and calibration center. → See **21.CONTACTING TECHNICAL SUPPORT.**

6-3. WARNING Alerts



Unplug from Mains Power

- **Stop using the instrument immediately if any of the following problems occur**
 - Unit emits smoke and an unusual smell
 - Water or other foreign material has got inside the unit
 - Unit is dropped or damaged
 - AC power cable is damaged (possibly exposing or disconnecting the wires, etc.)

Continuing to use the instrument in a faulty condition risks causing fire, electric shock, or similar. Disconnect from the power supply immediately and unplug the AC plug from the socket.

After confirming that no more smoke is being emitted, send the instrument to your sales agent or the Noise Laboratory repair and calibration center for repair. → See **21.CONTACTING TECHNICAL SUPPORT.**

Repairing the instrument yourself is dangerous and should never be attempted.



Safety Rule

- **Turn the power switch to "Off" on the instrument before connecting or changing any of the cables**

Failure to comply with this rule may result in electric shock or misoperation.



Safety Rule

- **Only use the instrument with a power supply voltage and frequency that is within the indicated range (AC 100V to 240V, 50Hz/60Hz)**
Using the instrument with a power supply voltage or frequency outside the indicated range may result in fire or electric shock.
- **Firmly insert the AC power cable plug into the socket**
Failing to fully insert the plug may result in heating or the build-up of dust leading to fire, electric shock, or similar.
Plugging too many cables into the same power outlet may also cause cables to overheat leading to fire, electric shock, or similar.



Always earth correctly

- **Plug the AC power cable into a socket that has a protective earth terminal**
The AC power cable provided with the instrument has a three-pin plug that connects to the power supply and protective earth terminal.
The protective earth on the three-pin plug connects via the AC power cable to the metal parts on the instrument.
Because this provides protection from electric shock, ensure that you plug the power supply cable into a socket that has a properly earthed protective earth terminal.
Using the instrument without a protective earth connection may result in electric shock.

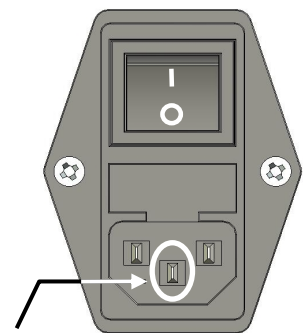

Protective earth



Prohibited

- **Do not insert objects into the instrument or its connectors**
Inserting metallic or flammable items into the ventilation slits, connectors, or other openings may result in fire, electric shock, or similar.
- **Do not touch the tip of the discharge gun while the instrument is operating**
Failure to comply with this rule may result in electric shock or injury.
- **Do not aim at a person during testing**
This is very dangerous and may result in unexpected injury so should never be attempted.
- **Do not install in a location that obstructs access to the power supply, STOP, and other switches**
Failure to comply with this rule may prevent you from reacting quickly when a problem occurs and may result in fire or electric shock.
- **Do not use the AC power cable for any purpose other than this instrument**
The supplied AC power cable is only intended for use with this instrument. Do not use it for any purpose than this instrument. Use on any other electrical equipment risks overheating leading to fire, electric shock, or similar. Similarly, using an AC power cable from another electrical device may prevent the instrument from operating at its intended level of performance and may result in overheating if the current carrying capacity of the cable is insufficient, leading to fire, electric shock, or similar.

- **Do not damage the AC power cable**

Damage to the AC power cable may result in fire, electric shock, or similar. Take particular care in relation to the following precautions.

- Do not manipulate the AC power cable
- Do not bend the AC power cable excessively
- Do not twist the AC power cable
- Do not pull the AC power cable
- Do not locate the AC power cable close to a heater
- Do not place heavy objects on the AC power cable

6-4. CAUTION Alerts



Safety Rule

- **If condensation appears after the instrument is moved from a cold to a warm location, allow to dry naturally before using**
Using the instrument while condensation is present may result in electric shock, faults, or fire.
- **Clean the AC plug periodically**
Allowing dust or dirt to accumulate between the AC plug and socket and absorb moisture may reduce the electrical insulation and result in fire. Periodically unplug the AC plug from the mains socket and clean off any dirt or dust using a dry cloth.
- **Clean the high-voltage input and output connectors periodically**
Allowing dust or dirt to accumulate between the high-voltage input connector and high-voltage output connector and absorb moisture may reduce the electrical insulation and result in fire. Periodically unplug the AC plug from the mains socket, wait for five or more seconds, then unplug the high-voltage input connector from the high-voltage output connector and blow dehumidified air into the high-voltage output connector to clean out any dust or dirt. Also clean off any dirt or dust on the high-voltage input connector using a dry cloth.
- **If the instrument becomes dirty, clean with a dry cloth**
Never use benzene, thinner or other solvents as these may degrade the exterior surface or printed text.
If the exterior, operation panel, or other parts of the instrument become dirty, wipe with a dry soft cloth. If the dirt is difficult to remove, moisten the cloth with water or apply a small quantity of a neutral detergent to the cloth. Wipe dry after using these to clean the instrument.
- **Ensure that the safety warning labels are always visible**
If the safety warning labels become dirty or start to peel off, please reattach them for safety. If the labels are lost, please contact your sales agent or the Noise Laboratory repair and calibration center for replacements. → See **21.CONTACTING TECHNICAL SUPPORT.**



Prohibited

- **Do not use the instrument with other than a recommended discharge gun**
Using the instrument with other than a recommended discharge gun may result in poor operation and abnormal test results. → See エラー! 参照元が見つかりません。 **Function Restrictions and Compliance Standards by Combinations with Discharge Gun.**
- **Do not apply static electricity to the instrument itself**
Failure to comply with this rule may cause the instrument to become faulty.
- **Do not install the instrument in any of the following locations**
Installing the instrument in any of the following locations may result in fire, electric shock, and similar.
 - Humid or dusty environments
 - Locations where the instrument is likely to become hot such as close to a heater or exposed to direct sunlight
 - Locations where the instrument is likely to get wet such as next to a window
- **Do not block the ventilation slits or use in a location with poor ventilation**
Do not block the ventilation slits on the instrument. Blocking the ventilation slits causes heat to build up inside the unit which may lead to fire. Take particular note of the following precautions.
 - Do not lie the unit face up, on its side, or upside down
 - Do not position in cramped locations with poor ventilation
 - Allow a gap of at least 10cm from walls and similar when installing
- **Do not unplug the high-voltage input connector by pulling on the cable**
Failure to comply with this rule may damage the cable, resulting in faults or fire. Hold by the high-voltage connector when unplugging.
- **Do not operate the instrument or insert or remove the AC plug or high-voltage input connector if you have wet hands**
Failure to comply with this rule may result in electric shock or faults.
- **Do not place water-filled containers on the instrument**
If the water is spilled and gets inside the instrument it may result in fire or electric shock.
- **Do not drop or subject to strong physical shocks**
Failure to comply with this rule may result in faults.
- **Do not knock or scratch with hard objects**
Such actions may damage the exterior coating or LCD panel.

* If this instrument becomes faulty during normal use, it will be repaired in accordance with the terms of the warranty. However, please note that the followings are exclusions from the warranty policy.

- Deterioration of consumables
- Faults caused by misuse, neglect, accident, or so on on the user side
- Faults caused by damage of the EUT or other peripheral equipment

And, besides, Noise Laboratory and its sales agents accept no liability for any compensation for losses or similar, or damage to the EUT (Equipment Under Test) or other peripheral equipment, which occurred as the result of ESD testing.

7. POINTS TO NOTE REGARDING CONSUMABLES ITEMS

● High-Voltage Relay

- The high-voltage relays contained in the main unit and in the discharge gun are consumable items.
- Their useful life varies depending on the use conditions and environment. The electrical contacts in the relays deteriorate with use and this can result in poor electrical connections, contact welding, or insulation failure occurring during normal use.
- If you experience problems such as being unable to apply a static discharge after starting a test or a static discharge occurs as soon as a high voltage is output, the cause may be deterioration of a high-voltage relay.

In this case, please contact your sales agent or the Noise Laboratory repair and calibration center. → See **21.CONTACTING TECHNICAL SUPPORT.**

Do not attempt to repair the instrument yourself as this is very dangerous.

● Fuse

- The instrument contains fuses.
- A fuse holder is located in the AC inlet on the rear panel (See **9-2. Main Unit (Rear Panel)**) and the fuse can be replaced by the user.

Please replace with a fuse of the following type.

Rated voltage 250V/Rated current 2A Slow-blow fuse

Recommended fuse: Little fuse 218.002P

Quantity: 2

- If unable to obtain the correct fuse, please contact your sales agent or the Noise Laboratory repair and calibration center. → See **21.CONTACTING TECHNICAL SUPPORT.**

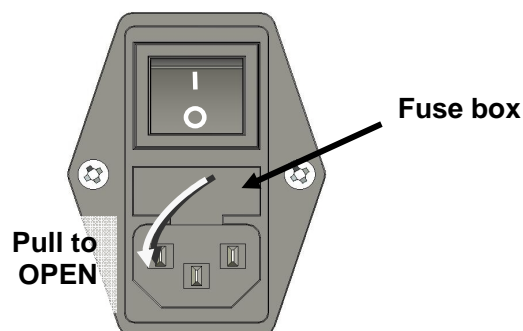





Figure 7.1 Fuse Box

8. INTRODUCTION

8-1. How to Read This Document

The symbols used in this document and their explanations are shown below.

	Indicates a supplementary explanation.
	Indicates where to refer to.
	Indicates that there is a setting restriction.
	Indicates that it must be checked before use.
[]	Indicates what is stated on the panel of the simulator.
[]	Indicates what is shown on the display section of the simulator.

8-2. Terms and Definitions

Term	Definition
EMC	Abbreviation of <u>E</u> lectro <u>M</u> agnetic <u>C</u> ompatibility. The concept which is generally required on electronic products and devices as a basic ability to radiate emission within the limit and to have enough immunity against external disturbances.
EMC technician	A person who has enough skill and knowledge in EMC field. In this manual, this term means especially a person who understands methods of ESD immunity testing well.
Protective earth terminal	An exclusively used terminal to ground a part of the electronic product, such as chassis, etc., where is likely to be touched by a human body, for preventing an electric shock in case of internal electric leakage of the product.
EUT	<u>E</u> quipment <u>U</u> nder <u>T</u> est. Equipment to be tested by test equipment.
Electrostatic discharge (ESD) immunity test	A category of immunity test which simulates electrostatic discharge phenomenon that a charged human body or object discharges to an electronic product.
Contact discharge	A method of the ESD immunity testing in which the discharge tip of the discharge gun is kept in contact with the EUT or coupling plane and the discharge is actuated by the discharge switch of the simulator. It is an unrealistic phenomenon in nature, but enables the test more reproducible.
Air discharge	A method of the ESD immunity testing in which the discharge tip of the discharge gun is moved towards the EUT until the tip touches the EUT. It is closer to natural phenomenon but has an unstable elements since it is dependent on test environment due to discharge in the air.
Discharge gun	A part of the simulator including charging and discharging circuit. One-hand handling is available.
CR unit	A part of the discharge gun equipped a charge capacitor (C) and a discharge resistor (R). The unit should be exchangeable to change the constant values of C and R on the circuit according to the standard requirement.
Gun head	A head part of the discharge gun. There are mainly two types, for IEC standard and for ISO standard. It should be exchanged according to the standard.
Discharge tip	Literally a "tip" part of the discharge gun. There are mainly two types, a conical type for contact discharge and a round type for air discharge.

9. NAME AND FUNCTION OF EACH PART

9-1. Main Unit (Front Panel)



Figure 9.1 Main Unit (Front Panel)

- (1) Company logo
Company logo.
- (2) High-voltage output connector
Connector with a maximum output voltage of 30.5kV. The discharge gun connects to this connector.
- (3) Carrying handle
Use this to carry or transport the instrument.
- (4) Operation switch section
It provides a dot matrix LED and various operation switches. → See **9-3. Operation Switch Section** for details.
- (5) Model name
The product name and model name of the instrument.

9-2. Main Unit (Rear Panel)

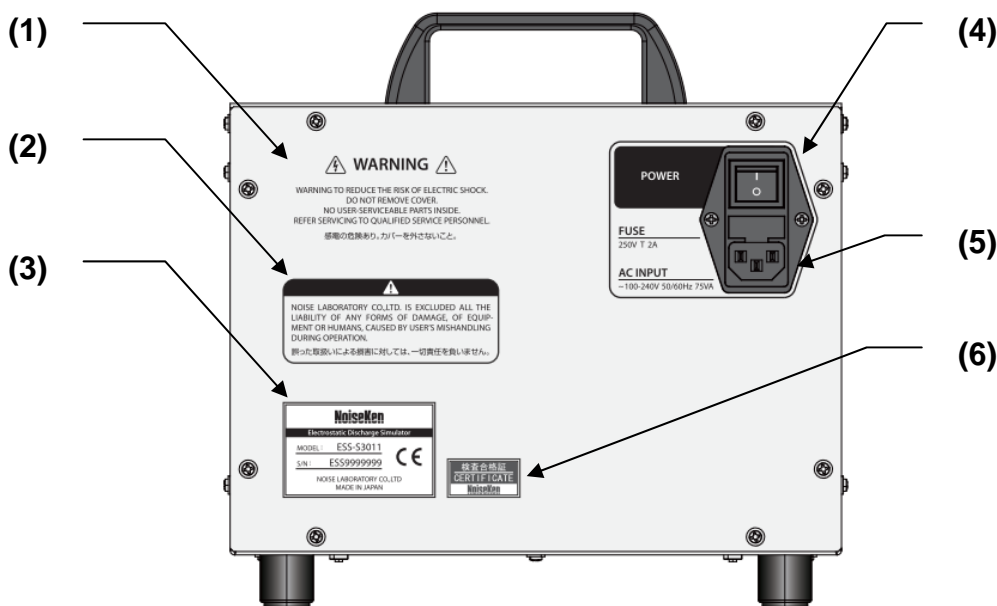



Figure 9.2 Main Unit (Rear Panel)

- (1) Warning text  **WARNING** 
 Indicates a warning, a risk of electric shock, that caution is required, and that you should refer to the instruction manual. Also includes a warning not to open the cover due to the risk of electric shock.
- (2) User warning
 Noise Laboratory Co., Ltd. accepts no liability for damages resulting from incorrect operation.
- (3) Serial number label
 Contains the model name, serial number, and other information.
- (4) Power switch 【POWER】
 Used to turn the power on and off.
- (5) AC inlet (with internal fuse box)
 Inlet used to plug in the supplied AC power cable. Includes an internal fuse.
 If replacing the fuse, → See **7. POINTS TO NOTE REGARDING CONSUMABLES ITEMS.**
- (6) Inspection certification
 Label certifying that the instrument passed the Noise Laboratory delivery inspection.

9-3. Operation Switch Section

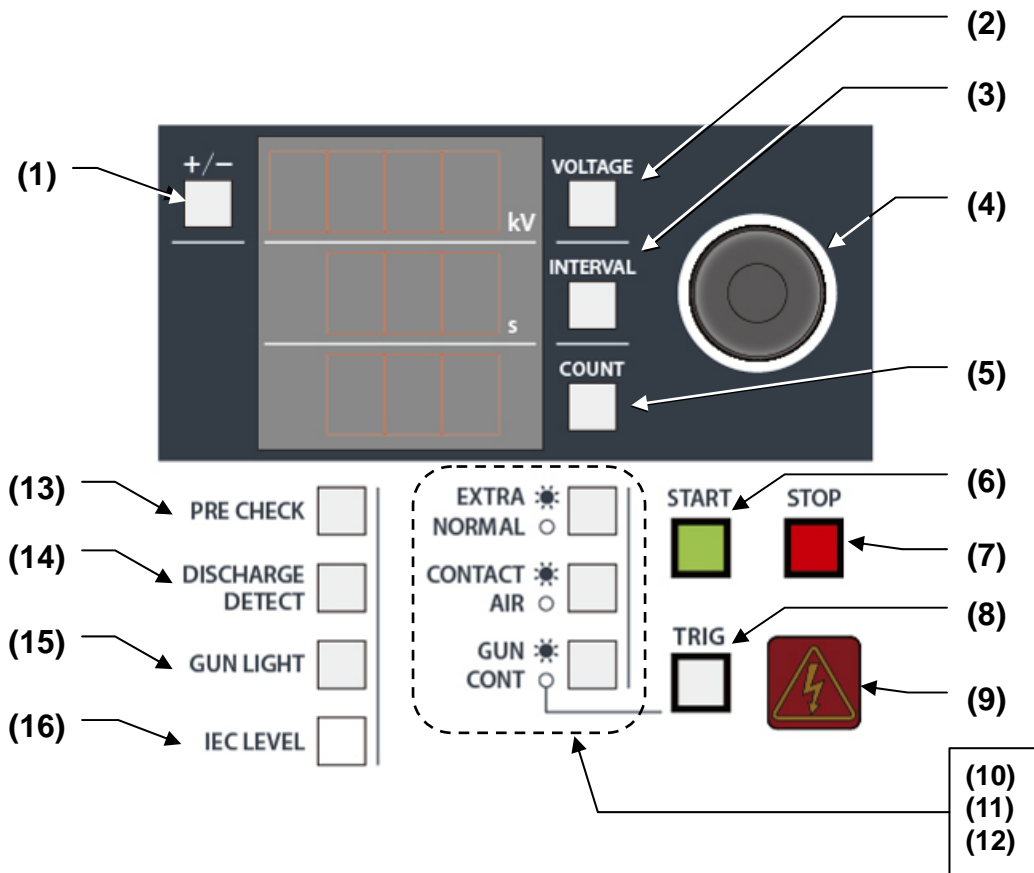

Figure 9.3 Operation Switch Section

- Display and test condition setting switch section
The following switches that correspond to various setting items are pressed to change their values or conditions using the rotary knob.
- (1) Output polarity selection switch 【+/-】
Changes the polarity of the output voltage.
- (2) Voltage setting switch 【VOLTAGE】
Changes the value of the output voltage.
- (3) Discharge interval setting switch 【INTERVAL】
Changes the discharge interval time.
- (4) Rotary knob
This rotary knob contains a push switch.
Rotating operation: Changes the value of a selected item.
Push operation: Moves the digit when the value to be changed is a numeric value.
- (5) Discharge count setting switch 【COUNT】
Changes the discharge count.

- Test execution switch section
 - (6) START switch 【START】
Switch used to start the test. Pressing this switch starts the high-voltage output.
 - (7) STOP switch 【STOP】
Switch used to stop the test. This shuts down the high-voltage power supply and turns off the high-voltage output from the main unit.
 - (8) TRIG switch 【TRIG】
Switch used to input the trigger from the main unit.
 - (9) Warning lamp
This WARNING lamp turns on/blinks during the test.
It turns on when a voltage is output from the high-voltage output connector and blinks when electrostatic discharging starts.

- Test mode setting switch section
 - (10) Radiation level mode switch 【EXTRA / NORMAL】
Switch used to change the radiation level from the discharge gun.
EXTRA: Extra mode (the switch's LED turned on)
NORMAL: Normal mode (the switch's LED turned off)
The initial setting and factory default setting are EXTRA.
For details, →see **13. RADIATION LEVEL MODE FUNCTION.**
 - (11) Test mode selection switch 【CONTACT / AIR】
Switch used to change the test mode (contact discharge/air discharge).
CONTACT: Contact discharge mode (the switch's LED turned on)
AIR: Air discharge mode (the switch's LED turned off)
 - (12) Trigger selection switch 【GUN / CONT】
Switch used to change the discharge trigger.
GUN: Gun trigger (the switch's LED turned on)
CONT: Controller trigger (the switch's LED turned off)

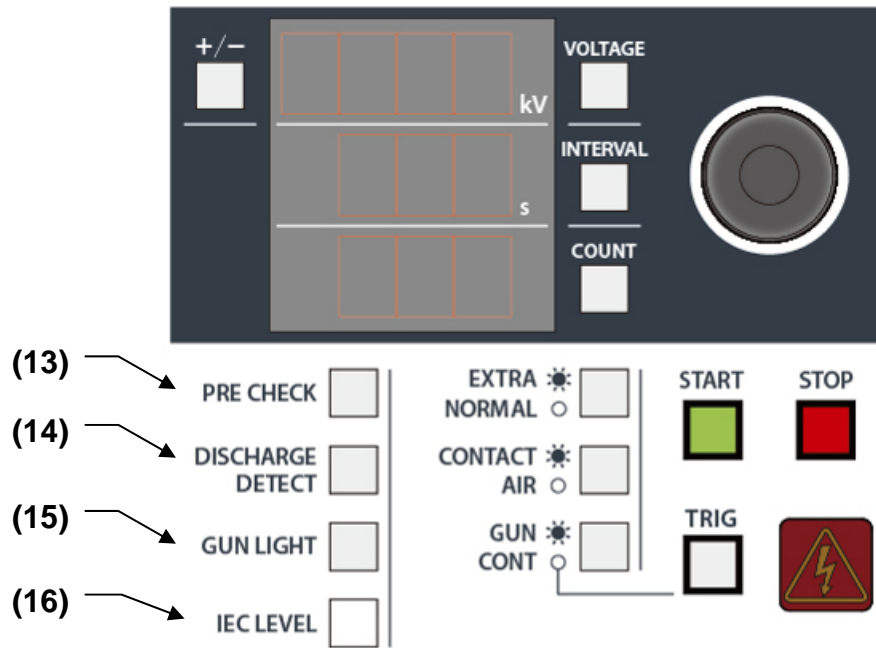

Figure 9.4 Operation Switch Section (Special switch section)

- Special switch section

(13) Pre-check switch 【PRE CHECK】

Switch used to perform the pre-check. For details, →see **15. PRE CHECK.**

(14) Discharge detection switch 【DISCHARGE DETECT】

Switch used to set the ON/OFF status of the discharge detection function.

ON: The switch's LED is turned on

OFF: The switch's LED is turned off

For details, →see **12-5. How to Set Special Functions.**

(15) Discharge gun LED light switch 【GUN LIGHT】

Switch used to set the ON/OFF status of the LED light provided to the discharge gun GT-30R. This LED light is turned on, only when the 【START】 switch is pressed. The ON/OFF status can also be changed during the test.

ON: The switch's LED is turned on

OFF: The switch's LED is turned off

(16) IEC test level switch 【IEC LEVEL】

This switch allows the voltage value to be set directly according to the test levels defined in IEC 61000-4-2 standard.

When CONTACT (contact discharge mode) is selected, it changes in the order of 2.0kV, 4.0kV, 6.0kV and 8.0kV. When AIR (air discharge mode) is selected, it changes in the order of 2.0kV, 4.0kV, 8.0kV and 15.0kV.

10. BASIC TEST FLOW

This section describes the basic flow of the test using the simulator and the discharge gun GT-30R.

1) Connection

Connect the AC power cable and the discharge gun (GT-30R).

For details, → see **11. DEVICE CONNECTIONS.**

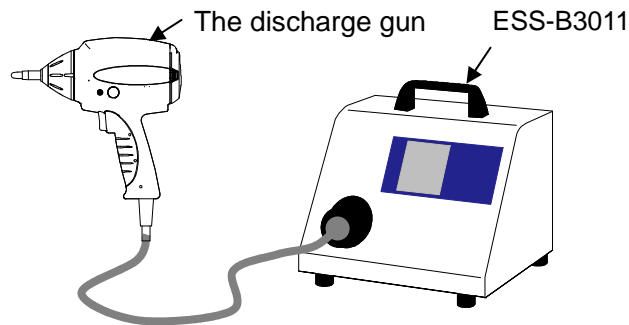

2) Test planning

What need to be set is determined, depending on whether the contact discharge test or air discharge test will be performed.

Contact discharge test

Perform discharge by having the discharge tip of the discharge gun contact the test specimen (EUT). Use the conical discharge tip (pointed type).

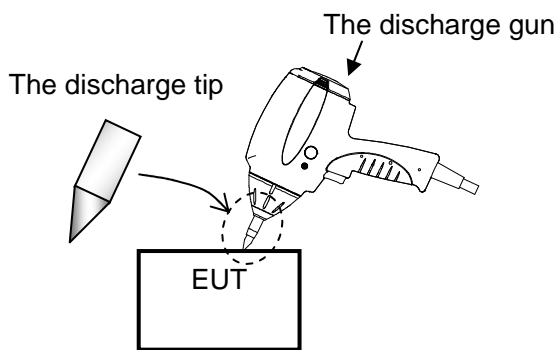

* Contact discharge test is further divided into direct and indirect discharge.

Direct discharge: Perform discharge by contacting EUT directly.

Indirect discharge: Perform discharge by contacting horizontal / vertical coupling plane. Indirect discharge is applied to EUT from the horizontal / vertical coupling plane.

Air discharge test

Perform discharge by placing the discharge tip charged at the test voltage close to the test specimen (EUT). Use the round discharge tip (round-headed type).

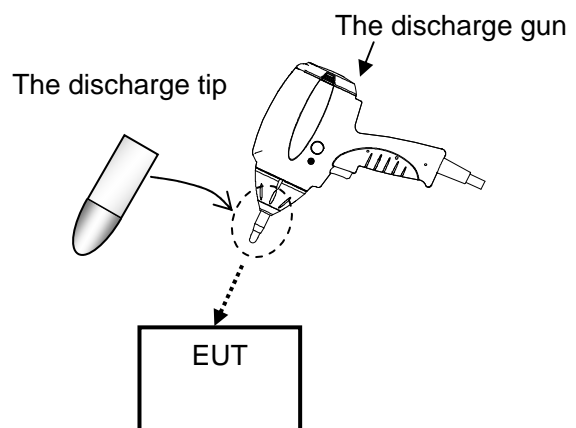

3) Basic settings

Set the following basic test parameters. For details, →see **12-3. Setting Basic Items**.

In this section, procedures of the gun-trigger method, holding the discharge gun by your hand, are described as an example.

- Polarity (+/-) and test voltage → (1), (2), (4)
- Discharge interval 【INTERVAL】 and discharge count 【COUNT】 → (3), (4), (5)

Contact discharge test

- Test mode: Contact discharge 【CONTACT】
- Trigger setting: Gun trigger 【GUN】 *1

Air discharge test

- Test mode: Air discharge 【AIR】 → (11)
- Trigger setting: Gun trigger 【GUN】 → (12)

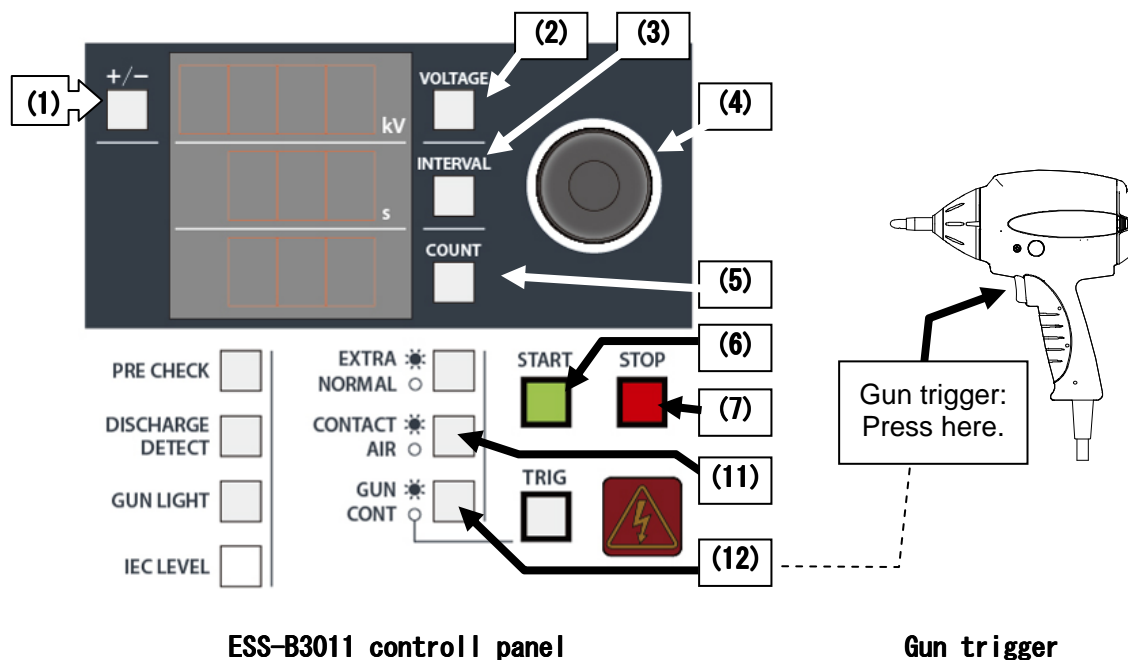

4) Performing the test

① Press the start switch **【START】** . → **(6)**

At the set high voltage, it is charged to the charge capacitor in the discharge gun.

Unless the trigger is input in this state, it is not output to the discharge tip.

② Input the trigger to discharge to EUT.

The procedure is different according to the test mode.

Contact discharge test

- 1) Make the discharge tip of the gun contacting to the EUT.
- 2) Press the trigger of the gun shortly and return it quickly.
- 3) The continuous discharge starts automatically with the previously-set interval. The set of discharges finishes when the discharge times reaches to the previously-set set number. Keep the discharge tip contacting to the same test point during the test.

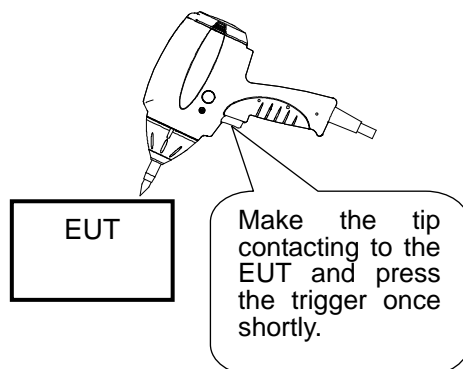

Air discharge test

- 1) Press the trigger of the gun with keeping proper distance from the EUT. Hold the trigger pressed until the following procedure 3).
- 2) Make the discharge tip close to the test point of the EUT quickly and touch it to the point.
- 3) Make the gun further away from the EUT after contact. Put the trigger back when the gun is far enough from the EUT.
- 4) A count of discharge consists of the above procedure 1)~3). Repeat the above 1)~3) until the previously-set discharge times completes.

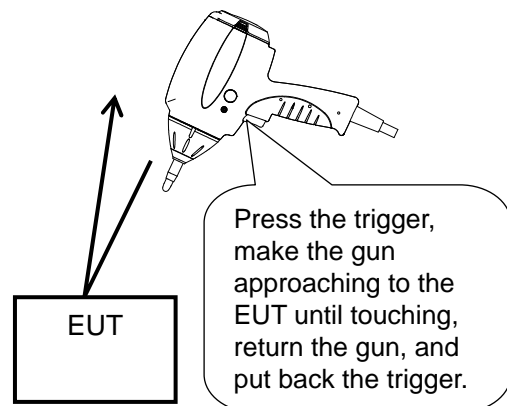

When the previously-set discharge times completes, one set of the test finishes.

The above status is waiting stage and the high voltage is still generating in the main unit.

- Inputting the trigger again restarts the test.
- Changing the output voltage is available in this status. → Rotate the rotary knob.

- ③ When one set of the test completes, press the stop key **【STOP】** to turn off the high voltage power supply. → **(7)**
- ④ Change conditions, such as polarity, output voltage, test mode and so on, and restart the test.
- ⑤ When a series of test completes, press the stop key **【STOP】** to turn off the high voltage power supply. → **(7)**

11. DEVICE CONNECTIONS

⚠ WARNING

- **Turn the power switch to "Off" on the instrument before connecting or changing any of the cables**
Failure to comply with this rule may result in electric shock, injury, or disoperation.
- **Do not insert objects into the instrument and its connectors**
Inserting metallic or flammable items into the ventilation slits, connectors, or other openings may result in fire, electric shock, or similar.

⚠ CAUTION

- **Do not use the instrument with other than a recommended discharge gun**
Using the instrument with other than a recommended discharge gun may result in poor operation and abnormal test results. → See [エラー! 参照元が見つかりません。](#) **Function Restrictions and Compliance Standards by Combinations with Discharge Gun.**
- **Clean the high-voltage input and output connectors periodically**
Allowing dust or dirt to accumulate between the high-voltage input connector and high-voltage output connector and absorb moisture may reduce the electrical insulation and result in fire. Clean them periodically with following procedures.
 - 1) Unplug the AC plug from the mains socket and wait for five or more seconds.
 - 2) Unplug the high voltage input connector from the high voltage output connector.
 - 3) Blow dehumidified air into the high voltage output connector to clean out any dust or dirt.
 - 4) Clean off dust or dirt on the high voltage input connector using dry cloth.
 - 5) Before connecting again, confirm no alien substance on the connectors.
- **Do not unplug the high-voltage input connector by pulling on the cable**
Failure to comply with this rule may damage the cable, resulting in faults or fire. Hold by the high-voltage connector when unplugging.
- **Do not operate the instrument or insert or remove the AC plug or high-voltage input connector if you have wet hands.**
Failure to comply with this rule may result in electric shock or faults.

11-1. Connecting the Discharge Gun

Align the groove on the high-voltage input connector from the discharge gun with the ridge on the high-voltage output connector on the main unit and insert. Rotate the securing ring on the high-voltage input connector from the discharge gun clockwise to secure in place.

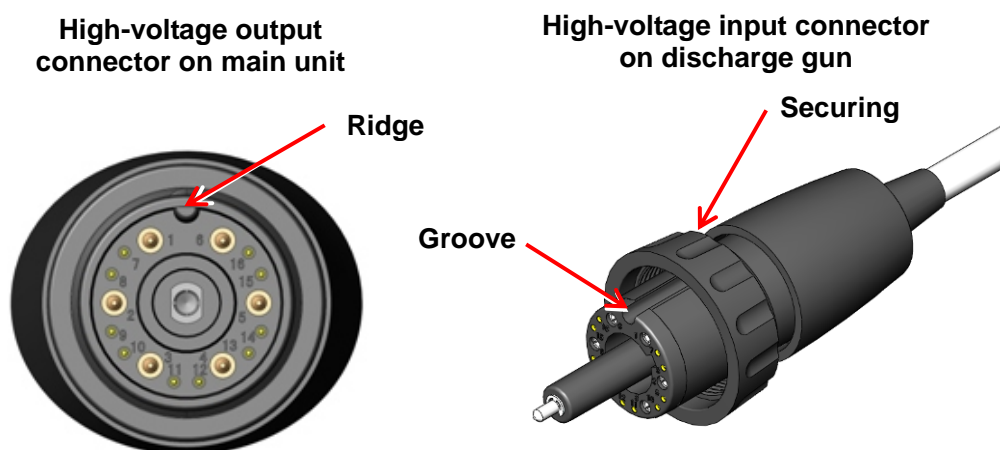

Figure 11.1 High-Voltage Input/Output Connector

11-2. Connecting the AC Power Cable

WARNING

- **Plug the AC power cable into a socket that has a protective earth terminal**

The AC power cable provided with the instrument has a three-pin plug that connects to the power supply and protective earth terminal. The protective earth on the three-pin plug connects via the AC power cable to the metal parts on the instrument. Because this provides protection from electric shock, ensure that you plug the power supply cable into a socket that has a properly earthed protective earth terminal. Using the instrument without a protective earth connection may result in electric shock.

- **Firmly insert the AC power cable plug into the socket**

Failing to fully insert the plug may result in heating or the build-up of dust leading to fire, electric shock, or similar.

Failing to fully insert the plug or plugging too many cables into the same power outlet may cause cables to overheat leading to fire, electric shock, or similar.

- **Do not use the AC power cable for any other purpose**

The supplied AC power cable is only intended for use with this instrument. Do not use it for any purpose other than this instrument. Use on any other electrical equipment risks overheating leading to fire, electric shock, or similar. Similarly, using an AC power cable from another electrical device may prevent the instrument from operating at its intended level of performance and may result in overheating if the current carrying capacity of the cable is insufficient, leading to fire, electric shock, or similar.

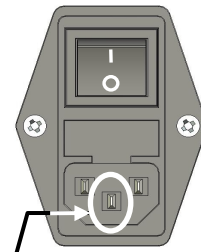

Protective earth terminal

Figure 11.2 AC inlet

CAUTION

- **Clean the AC plug periodically**

Allowing dust or dirt to accumulate between the AC plug and socket and absorb moisture may reduce the electrical insulation and result in fire. Periodically unplug the AC plug from the mains socket and clean off any dirt or dust using a dry cloth.

- **Do not operate the instrument or insert or remove the AC plug if you have wet hands**

Failure to comply with this rule may result in electric shock or faults.

Connect the supplied AC power cable to the AC inlet on the rear of the unit.

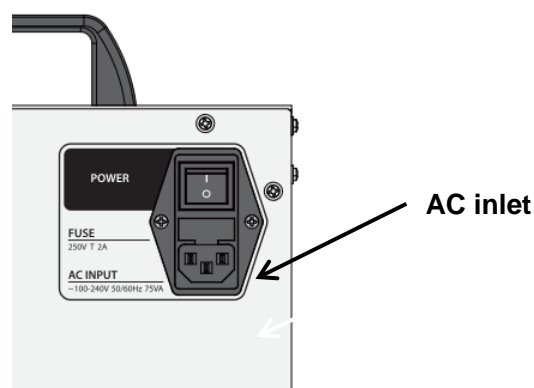

Figure 11.3 AC Inlet on Rear of Unit

12. OPERATION

12-1. Turning the Power On or Off

Press the "I" side of the power switch on the rear of the simulator to turn on the power. This lights up the operation panel display. Press the "O" side of the power switch to turn off the power and the operation panel display.

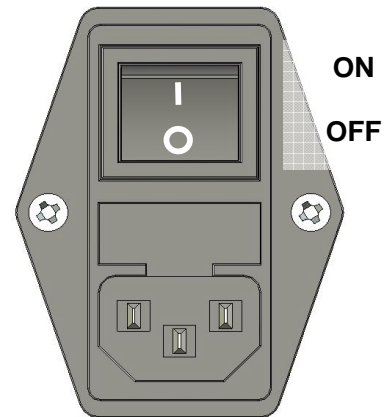

Figure 12.1 Power Switch

12-2. Test Condition Settings

Entering/changing values

The value of each setting item is entered and changed using the rotary knob.

The basic operation consists of ① Select the value or condition by pressing its corresponding switch, and ② Change the value or condition using the rotary knob.

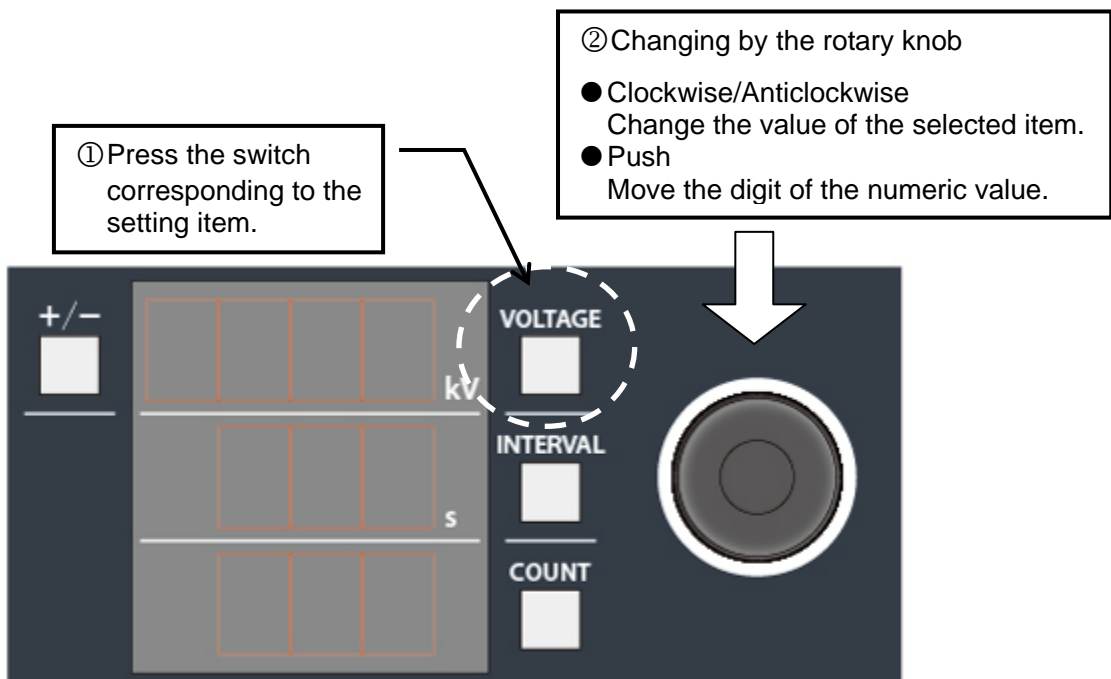

Figure 12.2 Basic Operation

12-3. Setting Basic Items

This section describes how to set the basic setting items such as the polarity, voltage, discharge interval and discharge count.

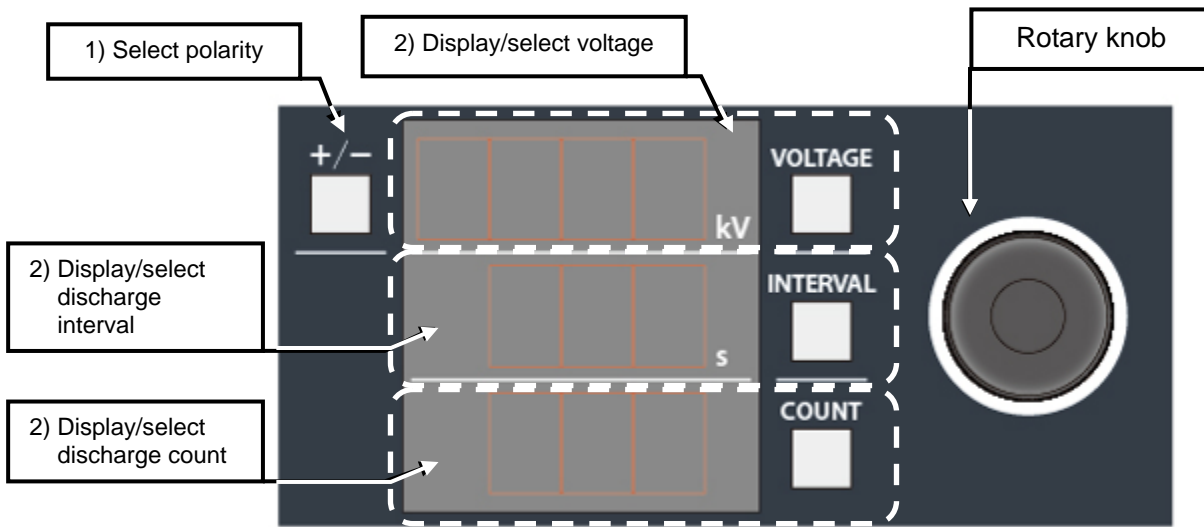

Figure 12.3 Setting Basic Items

1) Setting the polarity

The **polarity** is changed directly by pressing the polarity selection switch **【+/-】**.

2) Setting the voltage, discharge interval and discharge count

For the **voltage** **【VOLTAGE】**, **discharge interval** **【INTERVAL】** and **discharge count** **【COUNT】**, their corresponding switches are pressed first. Then their values are changed using the rotary knob.

- Voltage **【VOLTAGE】** : Can be changed during the test (after START).
- Discharge interval **【INTERVAL】** : Applies to contact discharge only.

Test Mode	Discharge Interval 【INTERVAL】 Setting Value
Contact discharge mode 【CONTACT】	0.05s to 99.9s
Air discharge mode 【AIR】	Manually *1

*1) **Manually**: Discharged every time the trigger is input. Displayed as **[- - -]**

- Discharge count **【COUNT】** : Enabled to set 1 to 999 times as well as continuous setting.
 “Continuous setting”: Set by lowering the lower limit [1] further by one step.
 In that case, it is displayed as **[Cnt] (Continue)**.

12-4. Setting Test Mode

This section describes the test modes (contact discharge and air discharge) and the trigger settings.

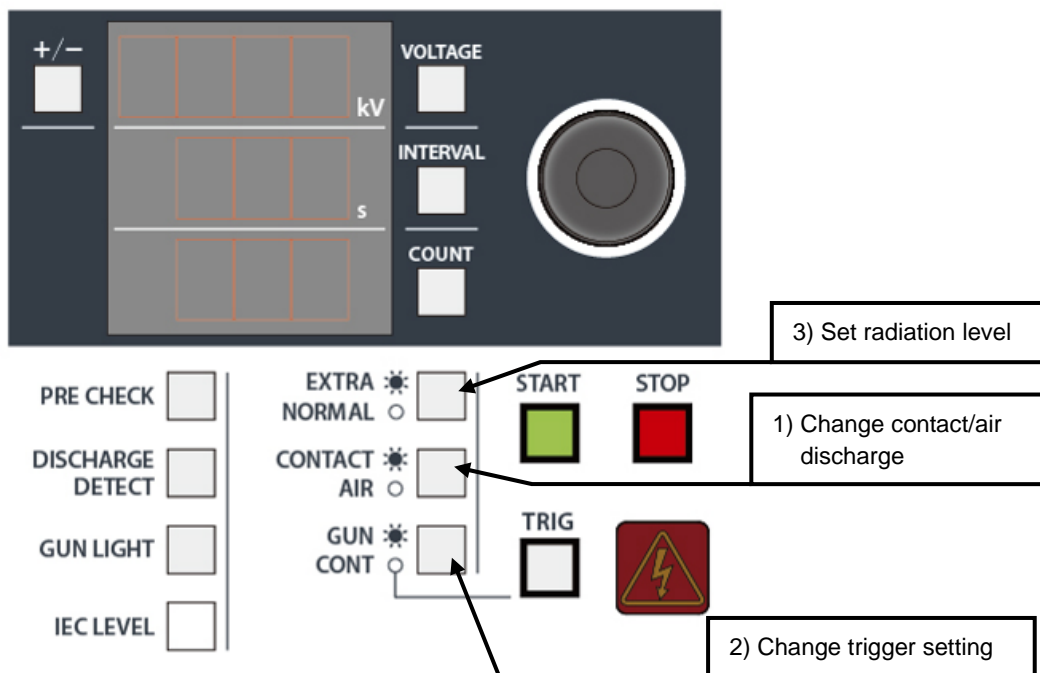

Figure 12.4 Setting Test Mode and Trigger

1) Changing between contact and air discharge

The test mode is selected from **contact discharge** **【CONTACT】** and **air discharge** **【AIR】**.
The setting is changed over every time the **【CONTACT / AIR】** switch is pressed.

Contact discharge **【CONTACT】** The switch's LED is turned on
Air discharge **【AIR】** The switch's LED is turned off

2) Setting the trigger

It is selected from **gun trigger** **【GUN】** and **controller trigger** **【CONT】**.
The setting is changed over every time the **【GUN / CONT】** switch is pressed.

During the test

Gun trigger **【GUN】** The switch's LED is turned on..... Trigger switch on the discharge gun
Controller trigger **【CONT】** · The switch's LED is turned off..... Trigger switch on the main unit **【TRIG】**



When NoiseKen's previous discharge gun TC-815 series is attached to the probe stand, the trigger switch on the discharge gun remains pressed down. In this case, set the controller trigger **【CONT】**.

3) Setting the radiation level

The radiation level is selected from **extra mode** 【EXTRA】 and **normal mode** 【NORMAL】.

The setting is changed over every time the **【EXTRA / NORMAL】** switch is pressed.

Extra mode **【EXTRA】** ----- The switch's LED is turned on

Normal mode **【NORMAL】** ---- The switch's LED is turned off



For details of the radiation level modes, → see **13. RADIATION LEVEL MODE FUNCTION.**

12-5. How to Set Special Functions

This section describes the functions that are useful in performing the test as well as the pre-check for operational inspections.

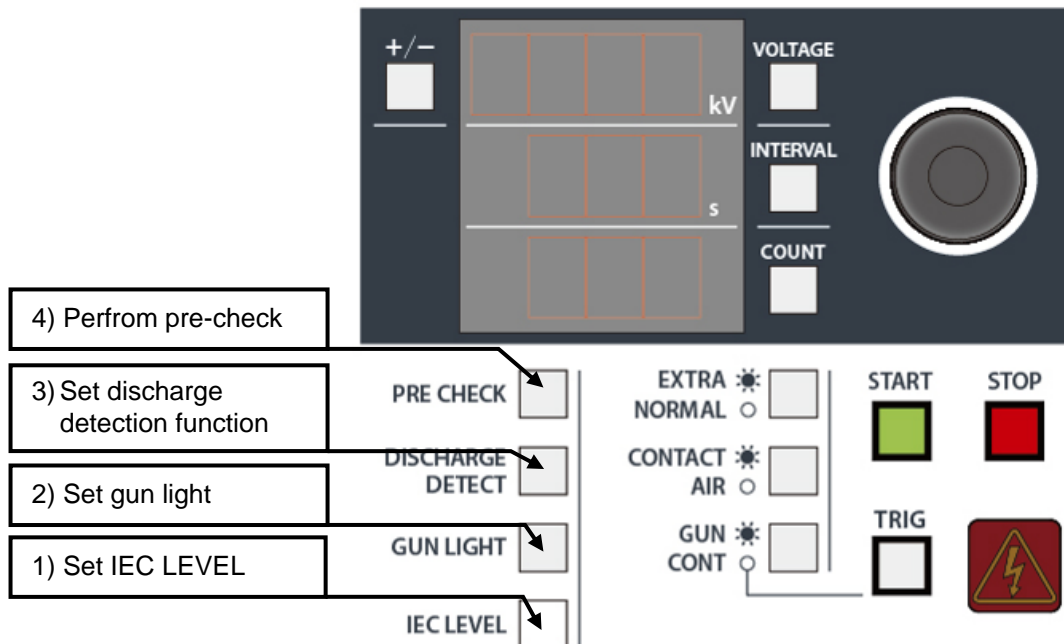

Figure 12.5 Setting Special Functions

1) Setting the IEC level

This function directly sets the voltage value to the test level conforming to IEC61000-4-2.

Pressing the **【IEC LEVEL】** switch sets the voltage value as shown in Table 12.1 below, according to the test mode. Every time it is pressed, the value goes up to the next step for each test level voltage. Once the highest limit is reached, it returns to the lowest value.

Table 12.1 IEC Level Switch

Test Mode	IEC Test Level
Contact discharge 【CONTACT】	↻ [2.0kV] → [4.0kV] → [6.0kV] → [8.0kV] ↻ ↑
Air discharge 【AIR】	↻ [2.0kV] → [4.0kV] → [8.0kV] → [15.0kV] ↻ ↑



The IEC level switch also functions during the test (after START). In the same way as for the time of setting, the test level can be changed according to Table 12.1.

2) Setting the gun light

The gun light function is used to turn on the LED light provided to the discharge gun GT-30R to illuminate EUT.

To use the LED light function of the discharge gun, turn on the 【GUN LIGHT】 switch.

During the test

【GUN LIGHT】 : ON Switch's LED: Turned on **Discharge gun light is turned on**

【GUN LIGHT】 : OFF Switch's LED: Turned off Discharge gun light is turned off



During the test (after START), the gun light switch can be turned on and off anytime.



When the discharge gun TC-815 series is used, the LED light does not function.

3) Discharge detection function

The discharge detection function detects the actual discharge in air discharge mode to notify the user.

To enable this function, turn on the 【DISCHARGE DETECT】 switch.

- The discharge detection function **only operates in air discharge mode**.

It starts in air discharge mode. When the trigger switch is turned on, the detection wait state sets in. After that, the detection operation stops, when a discharge is detected or the trigger switch is turned off.

When a discharge is detected, it operates as shown in Table 12.2 below.

Table 12.2 Operation of Discharge Detection Function

Item	【DISCHARGE DETECT】 ON		【DISCHARGE DETECT】 OFF
	When Discharge is Detected	When No Discharge is Detected	
Status display lamp on discharge gun	Red → Green	Remains red	Remains red
Buzzer sound	Short sound "pip"	No sound	No sound
Discharge counts	Counts up	Do not count up	Number of times the trigger operation is the discharge counts



- The discharge detection function is used to detect spark discharges caused by electrostatic discharges. In some cases, therefore, no discharge may be detected, depending on the impedance of the discharge channel and the charged status of the discharged object.
Moreover, no discharge may be detected, depending on the type of the CR unit (CR value) attached to the discharge gun.
- If the discharge detection function does not work under the above conditions, the sensitivity of the discharge detection function can be changed.

[Discharge detection function sensitivity setting]

- ① Press and hold the **【DISCHARGE DETECT】** switch for one second or more.
- ② Characters **[Lo / Mid / Hi]** will appear in the display section (normal setting: **[Mid]**).
- ③ Turn the rotary knob to select **[Lo]** for low sensitivity, **[Mid]** for normal sensitivity, or **[Hi]** for high sensitivity.



When the discharge gun TC-815 series is used, the discharge detection function is not available.

4) Performing the pre-check

Checks the operation of the internal high-voltage power supply of the simulator.

For details, → see **15. PRE CHECK**.

12-6. Performing a Test

1) Starting a Test

⚠ WARNING

- Before you start, check that the discharge gun is connected.
- Starting a test will generate the indicated voltage in the high-voltage output connector and discharge gun. Take adequate precautions.
- Take care to ensure there are no other people close to the discharge gun, and that all necessary preparation for the discharge test has been carried out.

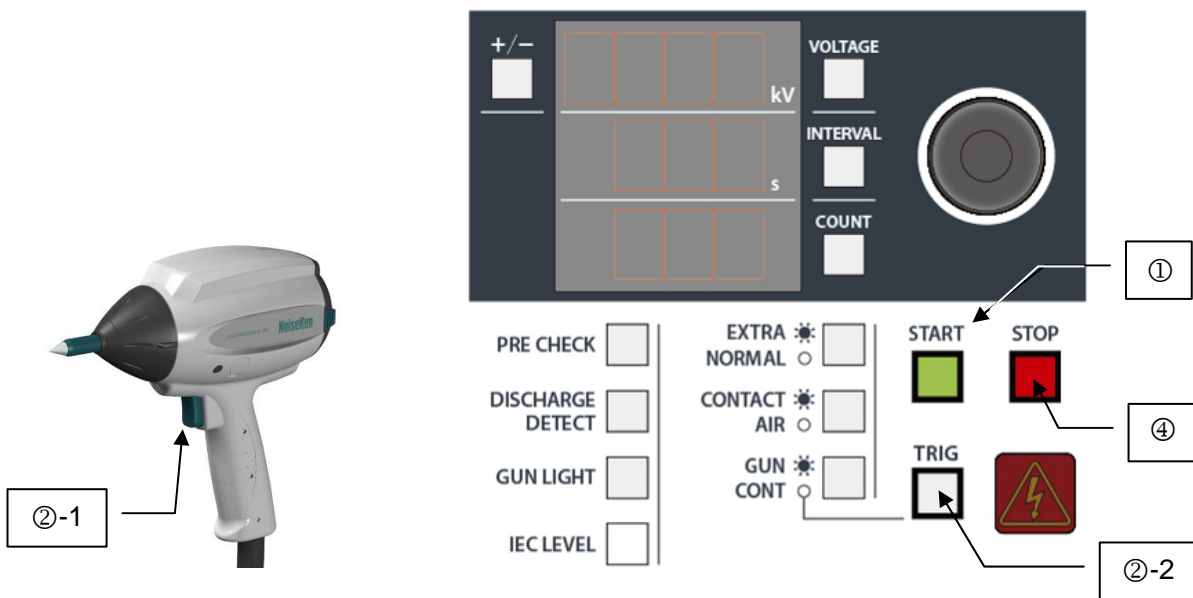



Figure 12.6 Procedure for Starting Test

- ① Pressing the **【START】** switch outputs a high voltage from the simulator. (The START switch and warning lamp illuminate)
- ② Inputting the specified trigger starts discharge testing. (The warning lamp blinks)
 - ②-1 Gun trigger **【GUN】**Press the trigger switch on the discharge gun
 - ②-2 Controller trigger **【CONT】** ·Press the trigger switch **【TRIG】** on the main unit (it blinks while waiting for input)

Table 12.3 shows how to use the discharge trigger in each test mode.

Table 12.3 Operation of Trigger Switches in Each Test Mode

Order	Contact Discharge Mode 【CONTACT】	Air Discharge Mode 【AIR】
i	Turn on the START switch.	
ii	Input the gun/controller trigger once. →The continuous discharge test starts.	Move the discharge gun away from EUT and press the gun/controller trigger. Place the discharge gun closer to EUT while holding it down.
iii	Discharge occurs at the set time intervals and continues automatically until the set count is reached.	Have the discharge tip contact the discharging location of EUT while holding the trigger down. Once EUT is contacted, move the gun away from EUT and release the trigger. The whole operation above is counted as one time.
iv	<u>Inputting the gun/controller trigger</u> ※ once stops continuous discharge temporarily. Inputting the trigger again restarts the discharge. ※When using at extra mode 【EXTRA】, press the main/gun trigger switch longer one or more seconds.	The above operation continues until the set count is reached.
v	Once it is counted up to the set discharge count, it enters a wait state.	
	<ul style="list-style-type: none"> ● If the trigger is released in air discharge mode before a discharge is performed, no discharge occurs to EUT. In this case, do it again from the beginning. ● It must be noted that even if the trigger is released in the middle of a session, that session is counted as one discharge into the total discharge count. →see 12-5. 3) Discharge detection function. 	

③ Once the specified number of discharges are completed, it enters a wait state. (The warning lamp is turned on.)

Inputting the discharge trigger again restarts the test.

2) Stopping a Test

WARNING

- The simulator waits for the next trigger input after the specified number of discharges have been performed.
The high-voltage power supply in the simulator does not turn off. Always press the STOP switch after the end of the test.

④ Pressing the 【STOP】 switch stops the test, turns off the high-voltage output, and turns off the warning lamp.

Pressing the 【STOP】 switch during the test turns off the high-voltage output immediately.

13. RADIATION LEVEL MODE

This simulator can reduce the radiation noise generated by the discharge gun.

13-1. Radiation Noise

When the internal high-voltage relay in the discharge gun is operated by inputting the trigger switch, a spark discharge unique to the high voltage occurs at the contact point with the internal high-voltage relay.

As this spark discharge occurs within the sealed high-voltage relay, it causes no direct danger to human bodies. It, however, may incur radiation noise, which impacts EUT.

This simulator has been improved so that the radiation level can be lower than our previous models. If differences of structure, radiation level and so on between this model and other models are taken into consideration, the test result may be thought different from what it could be otherwise.

Based on the above presumption, this simulator is equipped with a special function for lower radiation called extra mode **【EXTRA】** as a default setting and it can be switched to normal mode **【NORMAL】** easily to make the radiation level same as our previous models.

13-2. Differences between Radiation Level Modes

There are differences between extra mode (EXTRA) and normal mode (NORMAL), as shown below.

① Different level of radiated noise

The radiated noise in extra mode (EXTRA) is lower.

The radiated noise in normal mode (NORMAL) is at a similar level to previous simulators.

② Difference in the voltage waveform

There is a difference in the open voltage waveform of the discharge gun output. It can be expressed with test conditions, as shown below.

- Electrostatic discharge mode: Contact discharge mode
- Impedance between the discharge tip and discharge gun GND: 2MΩ or more



IEC 61000-4-2 and ISO 10605 standards do not stipulate any open voltage waveform.

For the current waveform using the specified target, there is no difference between extra and normal modes.



Testing in normal mode does not necessarily guarantee that test results will be identical to those obtained from previous simulators.

Electrostatic tests are affected by the individual variability of the simulator main unit and discharge gun.

They may also be affected by the test environment and arrangement method.

Voltage waveform measurement conditions

Impedance between the discharge tip and GND: approx. 100M Ω (1000:1 high-voltage probe used)

Simulator setting conditions: +2kV, contact discharge

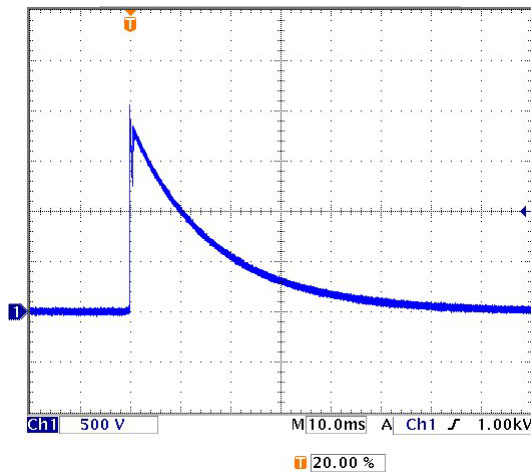

Extra Mode (EXTRA) Voltage Waveform

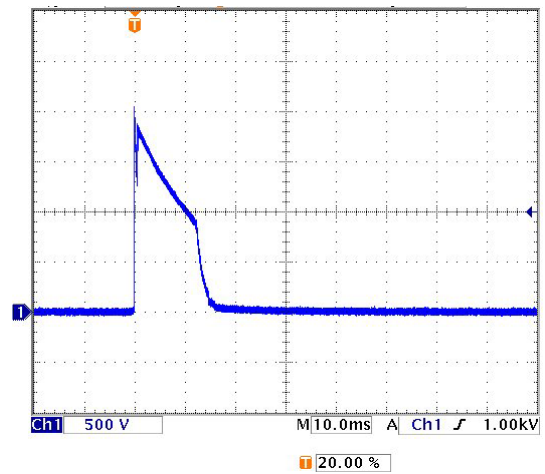

Normal Mode (NORMAL) Voltage Waveform

Figure 13.1 Open Voltage Waveforms

13-3. How to Set the Radiation Level Modes

To change from extra mode **【EXTRA】** to normal mode **【NORMAL】**, press the **【NORMAL / EXTRA】** switch in the operation switch section. Every time the switch is pressed, the setting is changed over. When the switch's LED is turned on, it indicates that **【EXTRA】** mode is selected.



If the discharge interval [INTERVAL] is 0.99 second or less when using at extra mode **【EXTRA】**, radiation level is equivalent to the normal mode **【NORMAL】**.

The switch's LED is still turned on extra mode **【EXTRA】**.

14. AUTOMATIC CR UNIT & DISCHARGE CUP RECOGNITION FUNCTION

The automatic CR unit & discharge cup recognition function is used to determine the type of the CR unit and the type of the discharge cup attached to the discharge gun as well as checking their combination.

It checks whether the combination complies with IEC 61000-4-2 and ISO 10605.

14-1. Operation of Automatic Recognition Function

When the CR unit or discharge cup for the discharge gun is replaced and the power of this instrument is turned on, automatic recognition is enabled to determine their types.

The CR unit and the discharge cup are determined separately. If their combination complies with a standard, the compliance standard is displayed.

It automatically determines whether or not the following standards are complied with:

- IEC 61000-4-2 Edition 1.2
- IEC 61000-4-2 Edition 2.0
- ISO 10605 1st Edition
- ISO 10605 2nd Edition

Once the CR unit and the discharge cup have been determined, a buzzer is sounded (“peep-pip” sound) and the compliance standard is displayed, only when it is one of the combinations shown in **Table 14.1** below.

No compliance standard is displayed for any other combination.

Table 14.1 Discharge Gun/Unit Combinations and Compliance Standards

CR unit	Discharge cup	Compliance standard	Display
150pF-330Ω	330Ω discharge cup	IEC 61000-4-2 Ed1.2 & Ed2.0 ISO 10605 2 nd Ed.	ISO2 IEC OK
330pF-330Ω	330Ω discharge cup	ISO 10605 2 nd Ed.	ISO2 OK
150pF-2kΩ	2kΩ discharge cup	ISO 10605 1 st Ed. & 2 nd Ed.	ISO OK
330pF-2kΩ	2kΩ discharge cup	ISO 10605 1 st Ed. & 2 nd Ed.	ISO OK



When the discharge gun TC-815 series is used, neither the CR unit nor the discharge cup can be determined.

14-2. Determining CR Unit

Table 14.2 below shows various types of CR units and their recognition displays.

When the discharge gun GT-30R is used, a test cannot be started unless a CR unit is set.

Table 14.2 Automatically Recognizable CR Units

CR Unit	Operational Restriction
Not attached	START disabled
150pF-330Ω	None
330pF-330Ω	None
150pF-2kΩ	None
330pF-2kΩ	None
C value disregarded-0Ω	None
Other (30kV-enabled unit)	None
Other (20kV MAX unit)	Maximum voltage: 20.0kV



When the discharge gun TC-815 series is used, the CR unit cannot be determined. There is also no operational restriction.

14-3. Determining Discharge Cup

Table 14.3 below shows the types of automatically recognized discharge cups.

When the discharge gun GT-30R is used, a test cannot be started unless a discharge cup is set.

Table 14.3 Automatically Recognizable Discharge Cup

Discharge Cup	Operational Restriction
Not attached	START disabled
330Ω discharge cup	None
2kΩ discharge cup	None
Other	None



When the discharge gun TC-815 series is used, the discharge cup cannot be determined. There is also no operational restriction.

15. PRE CHECK

As part of the operation check of the main unit, the output voltage of the internal high-voltage power supply of the simulator is checked. Perform this pre-check before the main test. This operation does not mean calibration of this model.



When the discharge gun TC-815 series is used, the pre-check function is not available.

15-1. Performing the Pre-check

- 1) Connect the discharge gun to main unit according to → **11-1.Connecting the Discharge Gun.**
- 2) Move the discharge gun away from the main unit and place it on an insulator.
- 3) Pressing the 【PRE CHECK】 switch on the front panel displays [Chk Rdy] (Check Ready) in the display section.
- 4) Pressing the 【START】 switch in that state starts the pre-check. During the pre-check, [Chk Run] (Check Run) is displayed.
- 5) The check takes approximately 20s.
- 6) Pressing the 【STOP】 switch suspends the pre-check immediately.

CAUTION 注意

- The pre-check function allows to check whether the internal high voltage power supply outputs correctly and charging the capacitor inside the discharge gun by internal high voltage.
- If the high voltage relay inside the discharge gun occurs voltage failure, it cannot detect. Even if the voltage failure occurs inside the discharge gun, the result of the pre-check might be OK.
- Do not touch the end of the discharge gun during the pre-check. If a pressure resistance failure occurs in the discharge gun, a discharge may occur to the end tip of the discharge gun.

15-2. Displaying the Result

Once the pre-check is completed, its result is displayed on the screen.

The high-voltage power check is performed for both the positive polarity [+] and negative [-] polarity.

- 1) When the pre-check is completed successfully
When the pre-check is completed successfully, [Chk +OK –OK] is displayed in the display section.
Pressing the 【STOP】 switch stops pre-check mode.

2) When an error occurs

When an error occurs during the pre-check, the pre-check is suspended and its result is displayed. See **Figure 15.1 Content of Pre-check Display**.

Pressing the **【STOP】** switch stops pre-check mode.

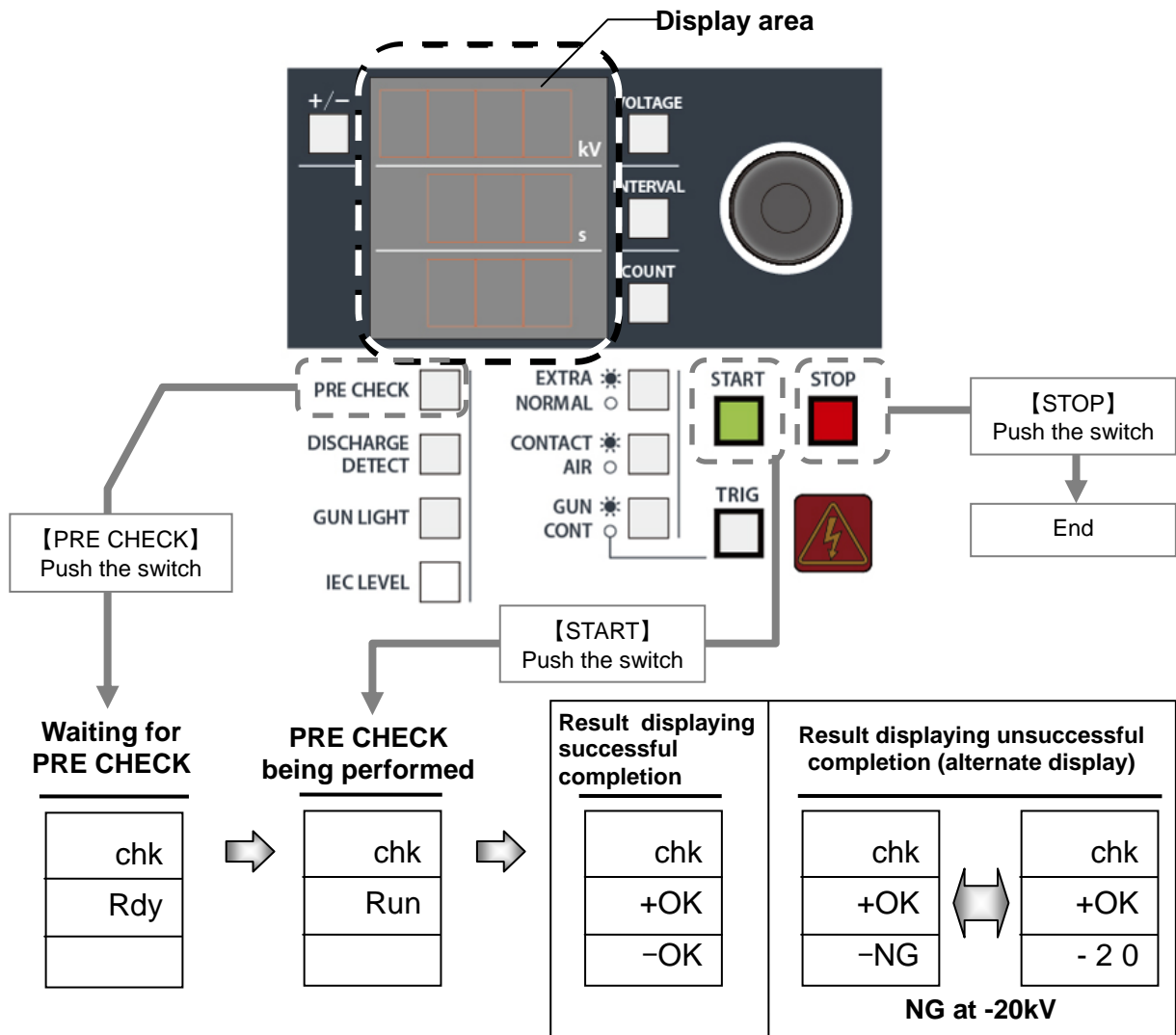

Figure 15.1 Content of Pre-check Display

15-3. ERROR Causes and Solutions

When an error occurs during the pre-check, the simulator or the discharge gun may be faulty.

Repair the simulator or discharge gun. → See **21. CONTACTING TECHNICAL SUPPORT**.

16. BACKGROUND KNOWLEDGE ABOUT ELECTROSTATIC TESTING

1) Principle of electrostatic tester

The basic circuit of an electrostatic is shown below.

① The high voltage generated in the high voltage power supply is charged in the charging capacitor through the charging relay and charging resistance.

➔ Pressing [START] status on this simulator

② When the charging relay is turned off and the discharging relay is turned on, the high voltage (electric charge) accumulated in the charging capacitor is applied to EUT through the discharging resistance.

➔ Inputting the trigger signal status on this simulator

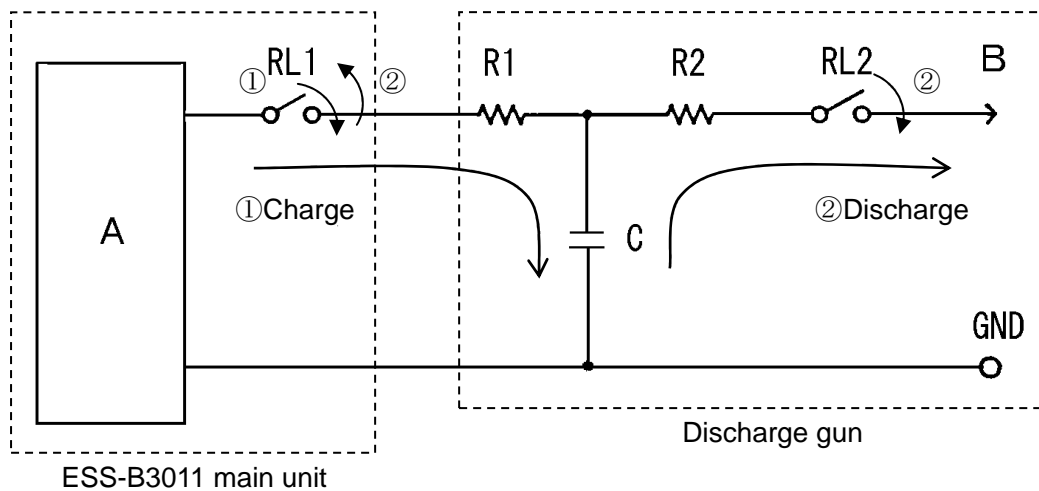

RL1 : Charging relay

RL2 : Discharging relay

R1 : Charging resistor

R2 : Discharging resistor

C : Charge/discharge capacitor A : High-voltage power supply B : Discharge tip

Figure 16-1 Basic Circuit for an Electrostatic Discharge Simulator

2) Electrostatic test by IEC standards

The international Electrotechnical Commission (IEC) issued the Standards for Electrostatic Discharge Requirements Pub. 61000-4-2, which defined tester circuits and constants, discharge current waveforms, test voltage levels, test environments, etc. A combination of the ESS-B3011 and discharge gun can be used for electrostatic discharge tests conforming to IEC pub. 61000-4-2.

3) Contact Discharge and Air Discharge

The electrostatic discharge can be applied either by direct contact (CONTACT) or via the air (AIR). The test procedure and electrostatic simulator operation are different in each case, as described below. The effect on the EUT is also different.

- Contact discharge (CONTACT)

The electrostatic discharge is applied by placing the discharge tip in direct contact with the case of the EUT (if the case is painted, the paint is peeled off to allow contact).

Coupling between the internal circuits and the discharge current that flows through the case of the EUT causes the EUT to malfunction. Because the discharge contacts the EUT directly, this method of testing has a comparatively good level of repeatability.

The test uses a cone-shaped discharge tip that extends out from the end of the discharge gun.

After bringing the discharge tip into contact with the measurement point on the EUT, the trigger is input to apply the specified number of discharges to the EUT at the specified time intervals. Discharging can be paused by inputting another trigger while discharge is in progress.

- Air discharge (AIR)

In the IEC standard, this method is used in situations when contact discharge is not practical (when it is stipulated that an insulating coating is applied or the EUT case is made of an insulator).

In this method, the discharge gun uses a discharge tip with circular shape.

Turn on the trigger with the discharge gun held away from the EUT and then as rapidly as possible bring the discharge tip closer until it comes into contact with the EUT. After the discharge occurs, pull the discharge tip (discharge gun) back away from the EUT and turn off the trigger. Repeat this the specified number of times.

Also, the discharge interval setting is not applicable when using air discharge mode.

4) Test Procedure for Electrostatic Testing

Electrostatic testing must be performed under specific conditions including factors such as the ground plane and coupling plane. Refer to the "IEC61000-4-2" standard published by the IEC for details.



As for the output waveform prescription, see the instruction manual of the discharge gun MODEL: GT-30R

17. ERROR DISPLAY

Table 17.1 Error List

ERROR 1	
Description of error	Discharge gun interlock error An interlock is present at the high-voltage output connector.
How to clear error	Push the STOP switch.
How to prevent error	Attach the high-voltage connector of the discharge gun correctly.
ERROR 3	
Description of error	Trigger error The trigger switch is stuck in the input position.
How to clear error	Push the STOP switch.
How to prevent error	Stop the trigger switch from remaining in the input position. Change the trigger selection.
ERROR 6	
Description of error	High-voltage power output error The output of the high-voltage power supply is unable to be confirmed.
How to clear error	Push the STOP switch.
How to prevent error	When this error occurs, the simulator and discharge gun may be faulty. For repairing the simulator and discharge gun, see <u>21. CONTACTING TECHNICAL SUPPORT.</u>
ERROR 8	
Description of error	CR unit or discharge cup recognition error Neither of them are attached or GT-30R is faulty.
How to clear error	Push the STOP switch.
How to prevent error	Attach the CR unit and discharge cup correctly. If the error continues even after they are attached correctly, they may be faulty. For repairing the simulator and discharge gun, see <u>21. CONTACTING TECHNICAL SUPPORT.</u>

* Error No. 2, 4, 5 and 7 are unassigned.

18. SPECIFICATIONS

Main Unit (ESS-B3011)

Parameters	Function/Performance
Output polarity	Positive or negative
Output voltage	0.20kV to 30.0kV (30.5kVmax) 0.20kV to 10.00kV: 0.01kV step setting 10.0kV to 30.0kV: 0.1kV step setting
Tolerance	0.20kV to 2.0kV±10% 2.0kV to 30.0kV±5%
Repeat cycle	0.05s to 99.9s±10% or manually 0.05s to 9.99s 0.01s step setting 10.0s to 99.9s 0.1s step setting
No. of discharges	1 to 999 times set in increments of 1, or continuous discharge
Electrostatic discharge mode	Contact discharge mode (CONTACT) or air discharge mode (AIR)
Radiation level mode	Extra mode (EXTRA) or Normal mode (NORMAL)
Trigger mode	Gun trigger or controller trigger
IEC LEVEL	Contact discharge mode: 2.0kV, 4.0kV, 6.0kV, and 8.0kV step settings Air discharge mode: 2.0kV, 4.0kV, 8.0kV, and 15.0kV step settings
Warning lamp	Turns on when a voltage is output from the high-voltage output connector Blinks when electrostatic discharging starts
Recommended discharge guns	GT-30R, TC-815R, TC-815S, TC-815-330/2K, TC-815S-330/2K
Charging resistor in simulator	10MΩ

Mains power supply	AC100V to AC240V ±10%, 50Hz/60Hz
Power consumption	75VA
Operating temperature range	+15°C to +35°C
Operating humidity range	25%RH to 75%RH (no condensation)
Storage temperature range	-10°C to +50°C
Storage humidity range	0%RH to 85%RH (no condensation)
External dimensions	(W)270mm × (H)263mm × (D)200mm
Weight	4.6kg (approx.)

19. WARRANTY

Servicing terms

The following terms are applicable to servicing by Noise Laboratory Co., Ltd., (hereafter referred to as the Company) provided to maintain the intended performance of its products.

1. **Scope**
The following terms shall apply only to products made by the Company.
2. **Technical servicing fee**
In the event of a failure of a product within the warranty period (see warranty section), the Company will repair a product without charge. After the warranty expires, repairs will be billed at a nominal cost.
3. **Ownership of replacement parts**
Any faulty parts replaced in the course of repair services shall belong to the Company. In the case when repairs are billed to the customer, replaced faulty parts will be retained by the Company unless other arrangements are made.
4. **Limited liability**
In the event that damages resulting from servicing by the Company are intentional or caused by negligence, the Company will pay the cost but at the purchase value of the relevant product maximum. But, notwithstanding the foregoing, the Company shall not be responsible for any incidental or consequential damages of any nature, including without limitation thereof loss of would-be profit or compensation demanded from a third party.
5. **Incorrect parts, missing parts, and damage**
In the event that the Company's product purchased by the customer has incorrect parts, missing parts, or is damaged, such that the product is not able to be used, the Company accepts no liability for any losses incurred by the customer that relate to lost earnings, commercial losses, other secondary losses, special losses, or indirect or punitive losses. Nor is any liability accepted for any losses resulting from a responsibility of the customer to compensate any third party.
6. **Refusal to provide repair services**
The company may not accept a repair order in the following cases:
 - More than 5 years have passed since the product discontinued
 - More than 8 years have passed after delivery
 - Required component for servicing already discontinued and no alternative is available.
 - Product changed, repaired or remodeled without obtaining a prior permission from the Company.
 - Product severely damaged to the extent it has lost its original form

Limited Warranty

Noise Laboratory Co., Ltd. (hereafter referred to as the Company) warrants its products to be free from defects in materials and workmanship under normal use and service for a period of one year from date of delivery. In the event of failure of a product covered by this warranty, the Company will repair the product or may, at its option, replace it in lieu of repair without charge.

Notwithstanding the foregoing, the Company shall not be responsible for any incidental or consequential damages of any nature, including without limitation thereof loss of would-be profit or compensation demanded from a third party. This warranty is valid only in Japan.

1. Scope

This warranty shall only apply to products made by the Company.

2. Period

One year from date of delivery.

The warranty may be valid in 6 months after servicing if the same failure on the same component has repeated.

3. Exclusions

The followings are exclusions from this warranty:

- ✧ Consumable parts (including mercury relay, HV relay, coaxial cable, coaxial connector, automatic switch, and contactor)
- ✧ Failure caused by misuse, neglect, accident or abnormal conditions of operation
- ✧ Failure caused by remodeling on the user side without prior permission from the Company
- ✧ Failure caused by servicing by unauthorized personnel by the Company
- ✧ Failure due to fore majeure including but not limited to, acts of God, fire, war, riot, rebellion and others
- ✧ Failure due to shock or drop in or after transit
- ✧ Failure due to operation in environment being out of ambient specifications.
- ✧ A unit shipped to overseas

20. MAINTENANCE

1. When repair, maintenance or internal adjustment of the unit is required, a qualified service engineer takes charge of such work.
2. Maintenance on the user side is restricted to the outside cleaning and functional check of the unit.
3. When checking or replacing the fuse, turn off the switch of the unit and disconnect the plug socket beforehand.
4. When cleaning the unit, turn off the switch of this unit and the connected equipment and disconnect the plug socket beforehand.
5. Avoid using chemicals for cleaning. Otherwise, the coating of the unit may peel off or the sight glass may be broken.
6. Do not open the cover of this unit.

21. CONTACTING TECHNICAL SUPPORT

- If you experience a malfunction, please have available both the model and serial number of your unit and contact the nearest distributor/agent or Noise Laboratory Technical Support.
- When it is necessary to send your unit back to Noise Laboratory, fill in the repair order form completely, pack the unit in the original package or equivalent one suitable for transit, and send the package.

Customer Service Center

TEL +81-42-712-2051
FAX +81-42-712-2050
E-mail:sales@noiseken.com

NOISE LABORATORY CO., LTD.

Produced by: Noise Laboratory Co., Ltd.

1-4-4, Chiyoda, Chuo-ku, Sagamiara City, Kanagawa Pref., 252-0237, Japan

TEL: +81-(0)42-712-2031 FAX: +81-(0)42-712-2030

URL: <http://www.noiseken.co.jp>

Printed in Japan