

INSTRUCTION MANUAL

FAST TRANSIENT BURST SIMULATOR

MODEL **FNS-AX3 A16C**

MODEL **FNS-AX3 B50C**

NOISE LABORATORY CO., LTD.

NOTICE

- The contents of this instruction manual (the “Manual”) are subject to change without prior notice.
- No part of the Manual may be reproduced or distributed, in any form or by any means, without the authorization of Noise Laboratory Co., Ltd. (the “Company”).
- The contents of the Manual have been thoroughly examined. However, if you find any problems, misprints, or missing information, please feel free to contact our sales agent who you purchased our product from.
- The Company assumes no responsibility for any loss or damage resulting from improper usage, failure to follow the Manual, or any repair or modifications of this product undertaken by a third party other than the Company or the agent authorized by the Company.
- The Company assumes no responsibility for any loss or damage resulting from remodeling or conversion solely undertaken by the user.

Please note that the Company cannot be held responsible for any consequences arising from the use of this product.

1. IMPORTANT SAFETY PRECAUTIONS

The following instructions are very important for safe handling of the fast transient burst simulator FNS-AX3 A16C/B50C (hereinafter “the Unit”). They must be kept strictly to prevent users of the Unit from receiving harm or damage through using the Unit. Read them carefully before use.

- **Only well-trained EMC technicians (electric technicians) are allowed to use the Unit.**

The simulator used with the Unit may cause a fatal wound. Carefully handle it. And it may radiate electromagnetic noise which exceeds the regulation value. Take applicable countermeasures such as faraday cage, shield room, etc. as the need arises.

- **The Unit should be used only for EMC testing described in this manual.**

Using it for other purposes may result in a fatal or serious accident.

- **A person who has a pacemaker on should not operate the Unit and also should not enter the area where it is operating.**

It may result in a fatal or serious accident.

- **The Unit cannot be used in an explosive area, fire prohibited area, etc.**

Use of the Unit in such an area is liable to cause combustion or ignition.

A number of safety recommendations are listed in the later chapter "BASIC SAFETY PRECAUTIONS". Be sure to read them before test environment settings, connecting relating equipment and testing.

2. CONTENTS IN PACKAGE

This instruction manual (hereinafter “the Manual”) is available at FNS-AX3 A16C and FNS-AX3 B50C. The corresponding model is specified when function is different according to the model. The difference between FNS-AX3 A16C and FNS-AX3 B50C is as follows from the viewpoint of the power capacity of EUT (Equipment Under Test).

Model	EUT power capacity
FNS-AX3 A16C	Single-phase AC240V/DC125V 16A
FNS-AX3 B50C	3-phase AC500V/DC125V 50A

The following items are enclosed in the package. Check them when opening the package.

A



B



C



D

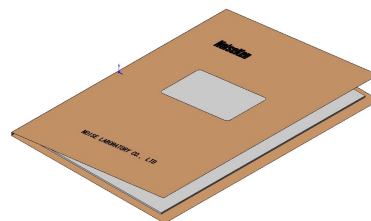

Description	Quantity
A: Main unit.....	1
B: SG cable (0.1m).....	1
C: AC cord.....	1
D: Instruction manual (this book).....	1

3. APPLICATION FORM FOR INSTRUCTION MANUAL

We place an order for an instruction manual.

Model: FNS-AX3 A16C / B50C _____

Serial No.: _____

Applicant:

Company name: _____

Address: _____

Department: _____

Person in charge: _____

Tel No.: _____

Fax No. _____

**Cut off this page “APPLICATION FORM FOR INSTRUCTION MANUAL”
from this volume and keep it for future use with care.**

When an INSTRUCTION MANUAL is required, fill in the above Application Form and mail or fax it to the following sales department of our company.

To: NOISE LABORATORY CO., LTD.

1-4-4 Chiyoda, Chuo-Ku, Sagamihara City, Kanagawa Pref.

252-0237 Japan

Tel: +81-42-712-2051

Fax: +81-42-712-2050

4. PREFACE

4-1. Preface

We thank you very much for your purchase of our Fast Transient Burst Simulator FNS-AX3 series (FNS-AX3 A16C, FNS-AX3 B50C, hereinafter “the Unit”). This instruction manual (“the Manual”) contains how to use the Unit and other important information. In order to obtain the highest performance from the Unit, thoroughly understand the contents of the Manual and use as ready reference for operation.

- **The Manual will help operators handle and utilize the Unit in safety.**
- **Keep the Manual in a place where it is readily available.**

4-2. Feature

The Unit generates Fast Transient Burst pulse prescribed in IEC61000-4-4.

Conforming to IEC 61000-4-4 Ed.3 (2012) and Ed.2 Amendment 1(2010)

- Equipped with a burst generating circuit and CDN based on the standard.
- Test conditions prescribed in the standard are preset in “Standard test” mode.

User-friendly LCD Control Panel

- Control panel adopts a color LCD.
- Capable of various kinds of setup with simple touch panel
- Employs push buttons for handling safety-related operation such as START/STOP.
- Easy to access screen for both on-desk and on-floor use.

Various Functions Broaden Horizons of Test

- Capable of setting up factors of burst waveform in “manual test” mode.
- Capable of varying test parameters during the test automatically in “sweep” mode
- Special functions effective for reproducing malfunction (Reverse polarity per burst, Pulse continuous output, Frequency modulation)
- Capable of saving user-made test contents with their name.
- Capable of conducting tests saved with “sequence test” mode in your specified order.

Customizable according to conditions of tests

- On “Utility” screen, conditions in conducting test are capable of being customized.

5. TABLE OF CONTENTS

1. IMPORTANT SAFETY PRECAUTIONS	1
2. CONTENTS IN PACKAGE.....	2
3. APPLICATION FORM FOR INSTRUCTION MANUAL	3
4. PREFACE.....	5
4-1. PREFACE.....	5
4-2. FEATURE.....	5
5. TABLE OF CONTENTS	6
6. BASIC SAFETY PRECAUTIONS	10
6-1. SYMBOLS OF HAZARD.....	10
6-2. SYMBOLS OF INSTRUCTION, WARNING AND CAUTION.....	10
6-3. DANGER.....	12
6-4. WARNING	12
6-5. CAUTION	14
7. CAUTION ABOUT EXPENDABLE SUPPLIES	16
8. INTRODUCTORY NOTES.....	17
8-1. INTRODUCTORY NOTES.....	17
8-2. TERMS AND DEFINITIONS.....	17
8-3. CHARACTERISTICS OF BURST GENERATOR	18
8-4. BLOCK DIAGRAM OF FNS-AX3	19
8-5. EXAMLE OF TEST	20
Example of Test to Power Line	20
Example of Test to Signal Line.....	21
9. APPEARANCE AND FUNCTION OF EACH PART.....	22
9-1. APPEARANCE OF THE MAIN UNIT	22

9-2. CONTROL PANEL.....	23
9-3. FRONT PANEL	24
9-4. REAR PANEL.....	25
10. CONNECTION.....	26
10-1. CONNECTING AC CORD.....	26
10-2. CONNECTING GROUND PLANE	26
10-3. CONNECTING LINE INPUT	27
10-4. CONNECTING LINE OUTPUT (POWER LINE)	29
10-5. CONNECTING COUPLING CLAMP	30
11. OPERATION.....	31
11-1. TURN ON FNS-AX3.....	31
11-2. EMERGENCY STOP BUTTON	32
11-3. MAIN MENU	33
11-4. SCREEN FLOWCHART.....	34
11-5. INPUTTING NUMBERS AND LETTERS (ABOUT TEN KEY AND CHARACTER KEY).....	35
12. SETTING UP STANDARD TEST	36
Selecting Coupling Line	38
12-1. EXECUTING STANDARD TEST.....	40
13. SETTING UP MANUAL TEST.....	44
Selecting Polarity	45
Setting Pulse Voltage	45
Setting Pulse Frequency.....	45
Setting Burst Period.....	45
Setting Number of Pulse.....	46
Setting Burst Duration.....	46
Selecting CDN Out or Pulse Out.....	48
Setting Coupling Way for CDN Coupling	48
Setting Test Time.....	50
13-1. SWEEP MODE	51
Setting Polarity Sweep.....	52

Setting Output Voltage Sweep	52
Setting Pulse Frequency Sweep	52
Setting CDN Sweep	53
13-2. SPECIAL FUNCTIONS	54
Setting Alternate Polarity	54
Setting Continuous Output	55
Setting Frequency Modulation.....	55
Setting External Trigger.....	56
13-3. TITLE SAVE / LOAD	57
Save	58
Load	59
Delete.....	59
13-4. EXECUTING MANUAL TEST	60
14. SETTING UP SEQUENCE TEST.....	64
14-1. MAKING SEQUENCE EXECUTION LIST.....	65
14-2. SAVING SEQUENCE EXECUTION LIST	67
Save	68
Load	69
Delete.....	69
14-3. EXECUTING SEQUENCE TEST	70
15. UTILITY	71
Setting EUT FAIL Signal	71
Burst Alarm Beep	72
Power ON Display.....	72
Setting up Common Items over Levels.....	72
Sequence Method	73
Prohibition of Title Operation.....	73
Language	73
16. OTHER FUNCTIONS	74
16-1. EUT FAIL FUNCTION	74
16-2. ALARM (WARNING LIGHT)	75
16-3. RETURNING TO INITIAL SETTING	75
17. ERROR MESSAGE.....	76



18. SPECIFICATIONS	77
18-1. SPECIFICATIONS OF GENERATOR.....	77
18-2. SPECIFICATIONS OF CDN.....	78
18-3. OTHER SPECIFICATIONS	79
18-4. APPEARANCE	80
19. OPTIONAL PRODUCTS	81
20. WAVEFORM VERIFICATION	82
20-1. VERIFICATION AT PULSE OUT	82
Waveform Verification with 50Ω Load (In Case of Using AT-810)	82
Waveform Verification with 1kΩ Load (In Case of Using AT-811).....	82
20-2. VERIFICATION AT EUT LINE OUT	84
Waveform Verification with 50Ω Load (In Case of Using 02-00131A and AT-810)	84
20-3. WAVEFORM FOR REFERENCE	86
21. WARRANTY	87
22. MAINTENANCE	89
23. NOISE LABORATORY SUPPORT NETWORK	90
24. INFORMATION FOR CE MARKING, EU AND EUROPEAN TERRITORIES	91

6. BASIC SAFETY PRECAUTIONS

- The following items are very important instructions which users must follow to take precautions against possible injury and harm.
- The indications are provided as an explanation of potential danger involved if the safety precautions are not observed correctly.









6-1. Symbols of Hazard

- ◆ The following display classifications describe degree, to which injury or harm might occur when the contents of the display are not followed or the Unit or related equipment is operated incorrectly.







 <h2 style="margin: 0;">DANGER</h2> <p>The contents of this display indicate “the assumption that imminent danger might occur resulting in death or serious injury” if the Unit or related equipment is handled incorrectly.</p>
 <h2 style="margin: 0;">WARNING</h2> <p>The contents of this display indicate “the assumption that there is a possibility of death or serious injury” if the Unit or related equipment is handled incorrectly.</p>
 <h2 style="margin: 0;">CAUTION</h2> <p>The contents of this display indicate “the assumption that there is a possibility of harm and the assumption that there is a possibility of physical damage” if the Unit or related equipment is handled incorrectly.</p>

6-2. Symbols of Instruction, Warning and Caution

- ◆ The following display classifications describe details that should be followed.

	Indicates attention (a matter that must be paid attention fully)		
	Indicates prohibition (an action that must not be taken)	 Prohibited	 Do not disassemble
	Indicates a compulsory action (an action that must be taken)	 Compulsory	

- ◆ The contents of following signs indicate warnings and cautions when using the Unit.

	<p>Noticing possibility of an electric shock It indicates that there is possibility of an electric shock.</p>
	<p>Noticing caution, warning and danger It indicates that there is a possibility of harm or physical damage if the Unit is or related equipment is handled incorrectly and that the Manual should be referred.</p>
	<p>It indicates warnings for electric shock etc. and the Manual should be referred.</p>
 <p>WARNING</p> <p>WARNING TO REDUCE THE RISK OF ELECTRIC SHOCK, DO NOT REMOVE COVER. NO USER-SERVICEABLE PARTS INSIDE. REFER SERVICING TO QUALIFIED SERVICE PERSONNEL. 感電の危険あり。カバーを外さないこと。</p> <p>NOISE LABORATORY CO.,LTD.IS EXCLUDED ALL THE LIABILITY OF ANY FORMS OF DAMAGE, OF EQUIPMENT OR HUMANS, CAUSED BY USER' S MISHANDLING DURING OPERATION. 誤った操作による損害に対しては、一切責任を負いません。</p>	<p>Notifying danger of electric shock and the Manual should be referred.</p> <p><u>Warning</u> To reduce the risk of electric shock, do not remove cover.</p> <p><u>Caution in handling</u> Noise Laboratory Co., Ltd. is excluded all the liability of any forms of damage, of equipment or humans, caused by user's mishandling during operation.</p>
 <p>感電防止のため、本器の駆動用 AC インレットの接地端子は AC ケーブルを通じて確実に大地アースに接続して下さい。</p> <p>TO PREVRNT ELECTRIC SHCOK, GROUND THIS UNIT VIA THE GROUND CONDUCTOR OF THE AC CORD.</p>	<p>Noticing importance of grounding.</p> <p><u>Warning</u> To prevent electric shock, ground this unit via the ground conductor of the AC cord.</p>
 <p>端子台のカバーを外す前に、EUT 供給電源が遮断されていることを確認して下さい。</p> <p>BEFORE REMOVING THE TERMINAL BLOCK COVER, CHECK TO SEE NO ELECTRIC POTENTIAL EXISTS.</p>	<p>Notifying danger of electric shock and the Manual should be referred.</p> <p><u>Warning</u> Before removing the terminal block cover to see no electric potential exists.</p>



6-3. Danger

 Do not disassemble	<p>Do not take the Unit apart or do not remodel. Do not open the cover.</p> <p>Imminent danger might occur resulting in death or serious injury. Repair, internal adjustment, and inspection of the Unit should be performed by a qualified service engineer. Ask the Company or its sales agent.</p>
---	--

 Prohibited	<p>Do not use the Unit in an explosive are or fire-prohibited area etc.</p> <p>Use of the Unit in such an area is liable to cause combustion or ignition.</p>
	<p>A person who has a pacemaker on should not operate the Unit and also should not enter the area where it is operating.</p> <p>It may result in a fatal or serious accident.</p>

6-4. Warning



 Compulsory	<p>Stop operation if following unusual phenomena should occur.</p> <ul style="list-style-type: none"> ○ Emitting fumes, or smelling. ○ Water or an unusual substance being stuck ○ Being dropped or being damaged ○ AC cable being damaged (e.g. core lines being exposed etc.) <p>Continuing to operate in the above status may result in a fire, electric shock, or injury. If an unusual phenomenon occurs, turn off power supply immediately, pull AC plug out of an outlet, and ask the Company or sales agent repair. As there is potential danger, any user must not repair the product.</p>
	<p>Insulate and protect the test facility against 4800V (Max. output voltage of the Unit).</p> <p>If the test facility is not so insulated and protected, there is the dangerous possibility of an electric shock, leak or fire.</p>
	<p>Turn off power supply of the Unit when setting or changing connection of related equipment.</p> <p>The misuse may cause electric shock, injury, or malfunction.</p>
	<p>Be sure to turn off power supply for EUT when connecting EUT to the Unit.</p> <p>The misuse may cause an electric shock.</p>
	<p>Use a proper EUT power supply equipped with protection network enough for EUT's current capacity.</p> <p>EUT line of the Unit does not have any protection network against over current. Connect an appropriate EUT power supply which has protection network (circuit breaker, fuse, etc.) to the input terminal of EUT line. If you fail to follow this precaution, the equipment or test facilities may be broken or be in danger.</p>

 <p>Compulsory</p>	<p>Do not supply over-rating power to EUT Line input terminal.</p> <p>Do not supply over-rating power to EUT line. The misuse may cause a damage of equipment or a fire. The rating of input is; A16C: Maximum voltage: AC240V, DC125V, Maximum current 16A (PE line: 10A); B50C: Maximum voltage: AC500V, DC125V, Maximum current 50A (N and PE line: 10A).</p>
	<p>Use the Unit after understanding instructions in the Manual fully.</p> <p>There may be danger causing a fatal or serious wound or emitting over-stricted-value electromagnetic noise in using the Unit. NOISE LABORATORY and its sales agents shall have no liability against any accident resulting in injury or death, any damage to equipment or any resultant damage thereof, which is caused by abuse or careless handling of this unit.</p>
	<p>Watch equipment while the Unit is operating.</p> <p>If this instruction should not be followed, a third person or equipment related to the test may be exposed to a danger.</p>
	<p>Supply power within the indicated range (AC100V~240V).</p> <p>The misuse may cause an electric shock or a fire. The attached AC cord in the accessory is for AC100~120V. Prepare a proper 3-line AC cord with a protective earth pin conforming to the local safety standard in using with AC220~240V power supply.</p>
	<p>Use proper connectors and cables and connect them securely.</p> <p>Avoid using a damaged connector or cable. The misuse may cause an electric shock or damage of equipment.</p>
	<p>Insert AC plug securely to the end.</p> <p>Insecure inserting generates heat and gathers dust. It may result in a fire or an electric shock. Avoid using a multiple outlet extension plug for the same reason.</p>
	<p>Install the Unit on a stable place.</p> <p>If the Unit is installed on an unstable place, human body may be in danger due to drop or overturn of the Unit.</p>
<p>Connect the protective earth of AC cord.</p> <p>Using the Unit without connecting it may cause an electric shock.</p>	
 <p>Prohibited</p>	<p>Do not use the Unit for any other purpose than EFT/B test.</p> <p>The misuse may result in an electric shock, an injury, or damage of equipment.</p>
	<p>Do not put any substance into the Unit or its connectors.</p> <p>If some metal or flammable things are put into the Unit through a connector or a vent, it may result in a fire or an electric shock.</p>
	<p>Do not install the Unit on the spot where quick operation of power key or STOP key is difficult.</p> <p>If the simulator is set up on such a spot, difficulty in taking action in emergency may result in a fire or an electric shock.</p>

 Prohibited	<p>Do not use the attached AC cord for any other purpose.</p> <p>The misuse may result in a fire or an electric shock.</p>
	<p>Do not damage AC cord.</p> <p>A damaged AC cord may cause a fire or an electric shock. For HV cable, be sure to take notice following points.</p> <ul style="list-style-type: none"> ○ Do not work it. ○ Do not bend it forcibly. ○ Do not twist it. ○ Do not pull it. ○ Do not move it close to heat. ○ Do not put heavy things on it.

6-5. Caution

 Compulsory	<p>Take actions against emission of electromagnetic waves.</p> <p>When a test is performed using the Unit, a great amount of electromagnetic waves are emitted according to the type of EUT, sometimes adversely affecting the neighboring electronic equipment and radio communication apparatus. The user is required to provide a Faraday gage, shield room, shielding cable, etc. as necessary.</p>
	<p>Connect EUT power supply only to EUT LINE input terminal.</p> <p>If EUT power supply is connected directly to PULSE OUT connector, EUT FAIL input terminal, or other parts of the Unit.</p>
	<p>If dewing occurs, fully dry up the Unit before using it.</p> <p>Dews may cause an electric shock, a trouble, a fire.</p>
	<p>Use the Unit in proper environment.</p> <p>Operating temperature range is 15~35°C. Operating humidity range is 25~75%. If these precautions are not followed, the unit may be broken or the prescribed performance may not be warranted.</p>
	<p>Clean up the AC plug periodically.</p> <p>If dust gets damp between the AC plug and outlet, insulation capability deteriorates. It may result in a fire. Pull the AC plug out from an outlet periodically and wipe it with a dry cloth.</p>
<p>Clean up PULSE OUT connector periodically.</p> <p>If dust gets damp in PULSE OUT connector, insulation capability deteriorates. It may result in a fire. Clean up PULSE OUT connector periodically. Be sure to pull the AC cord out from the outlet to make the Unit turning off before cleaning and blow dehumidified air to PULSE OUT connector to blow off dust.</p>	

 Compulsory	<p>When the body is dirty, wipe the body with a dry cloth.</p> <p>Do not wipe the Unit and Probe with thinner, alcohol or other solvent. When the body is very dirty, soak a cloth into neutral detergent, squeeze out the detergent from the cloth and wipe the body with the cloth.</p>
	<p>Make hazardous labels always noticeable.</p> <p>When the caution or warning label is peeled off, missing or dirty, attach a new one for securing safety. When the caution or warning label is missing, ask the sales department or maintenance section of our company to send a new label.</p>
 Prohibited	<p>Do not install the Unit on following places.</p> <p>Setting up the Unit on wrong places as follows may result in a fire, an electric shock, or an injury.</p> <ul style="list-style-type: none"> ○ A very humid or dusty place ○ A hot place, e.g. a place exposed to direct rays of the sun, a place close to a heater. ○ A place easy to bedew, e.g. a place close to a window.
	<p>Do not block a vent or do not use the Unit in a place poorly ventilated.</p> <p>If a vent is blocked, the internal heat is close. It may cause a fire. For ventilation, be sure to take notice following points.</p> <ul style="list-style-type: none"> ○ Do not lay the Unit on its back, sideways, or upside down. ○ Do not put the Unit into a small, poorly ventilated place. ○ Keep the Unit at least 10cm away from a wall or some substance.
	<p>Do not handle the AC plug with your hand wet.</p> <p>The misuse may result in an electric shock or trouble.</p>
	<p>Do not put any container containing water on the Unit.</p> <p>If water is spilled or gets into the Unit, it may result in a fire or an electric shock.</p>
	<p>Do not drop or shock the Unit excessively.</p> <p>The misuse may cause trouble or damage.</p>
	<p>Do not bump or rub the Unit against something hard.</p> <p>The misuse may damage a surface of the Unit.</p>
	<p>Do not put any heavy thing or sit on the Unit.</p> <p>The misuse may result in a dent on the body or damage of internal components.</p>
	<p>Do not operate LCD panel with something sharp or pointed.</p> <p>The misuse may result in damage of the touch panel.</p>

7. CAUTION ABOUT EXPENDABLE SUPPLIES

● About a high voltage relay inside

- A high voltage relay used inside is an expendable component.
- The lifetime of it is dependent on using conditions and environment.
- If a symptom which seems to be caused by an exhausted high voltage relay, e.g. unstable current value, unstable repetition cycle or so on, is found, contact Noise Laboratory or your closest sales agent of Noise Laboratory. Repair by a user is impossible.

● Rechargeable battery for backing up memory







- A battery for backing up memory is expendable.
- Without being turned on for more than 2 months, a rechargeable battery will discharge and memory backup function will not work.
- If a rechargeable battery discharges, previously memorized contents, e.g. settings of "CALL" and indication in power OFF time, will return to the default values.
- For maintaining memory backup function, turn on the Unit for approximate 24 hours once every 2 months. (Recharging time is dependent on using condition and environment.)
- If memory backup function does not work even after charging the battery, the battery seems to be exhausted. Contact Noise Laboratory or your closest sales agent of Noise Laboratory. As repair by a user is very dangerous, do not repair unconditionally.
- ※ Noise Laboratory and its sales agent are not liable to loss of backup data caused by an exhausted battery, malfunction, malfunction, or so on.
As for important information, write down beforehand.

※ **In the event of failure in normal usage, repair shall be performed under the condition of the warranty rule. However, NOISE LABORATORY and its sales agents shall not be liable for any accident resulting in damage of DUT or peripheral equipment caused by deterioration of performance of expendable parts or any other external factors.**

8. INTRODUCTORY NOTES

8-1. Introductory Notes

The meaning of following symbols is as follows.

	Operate the touch panel.
	Additional explanation.
	Indicating other parts to be referred in the Manual.
	Indicating restriction of setting up.
	Indicating items to be confirmed before usage.
	Indicating text on the panel of the Unit.
	Indicating text on the LCD of the Unit.

8-2. Terms and Definitions

The terms and their definitions are shown as follows. Basically they come from IEC61000-4-4. For details, refer to the standard original.

Term	Difinition
Burst	Sequence of a number of distinct pulses or an oscillation occurring in a limited period.
Burst Duration	The length of time that a series of pulses are generating.
Burst Period	The length of time from the start of a burst to the start of the next burst.
EFT/B	Electrical Fast Transient / Burst A high-speed transient phenomenon caused by switching of an inductive load
Immunity	Ability of a device, equipment, or system to perform without degradation in the presence of electromagnetic disturbance.
Ground Plane	Ground Reference Plane Flat conductive surface whose potential is used as a common reference.
EUT	Equipment Under Test
Test for Power Line	Way of testing coupling high voltage pulses to AC/DC power supply port and/or protective earth of EUT. The test is conducted with using CDN.
CDN	Coupling/Decoupling Network Electrical circuit for the purpose of transferring energy one circuit to another (coupling) and preventing EFT voltage applied to the EUT from affecting other devices, equipment, and systems which are not under test (decoupling). It is prescribed in the standard.。
Test for Signal Line	Way of testing applying high voltage pulses to ports for I/O signal, data, and controll without direct coupling. The test is conducted with using coupling clamp.
Coupling Clamp	Device of defined dimensions and characteristics for common mode coupling of the disturbance signal to circuit under test without any galvanic connection to it.

8-3. Characteristics of Burst Generator

The burst waveform output by the Unit is shown as Fig. 8-1. The waveform of single pulse is prescribed with 50Ω load and 1kΩ load, shown as Fig, 8-2.

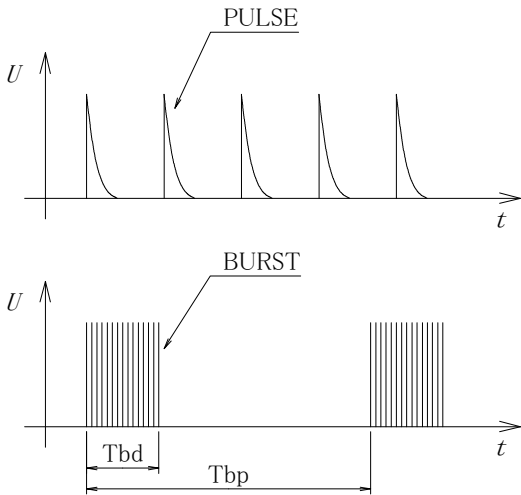

Output timing prescribed in IEC 61000-4-4

Pulse frequency	5kHz	100kHz
Tbd : Burst duration	15ms	0.75ms
Tbp : Burst period	300ms	

Fig 8-1 Burst waveform

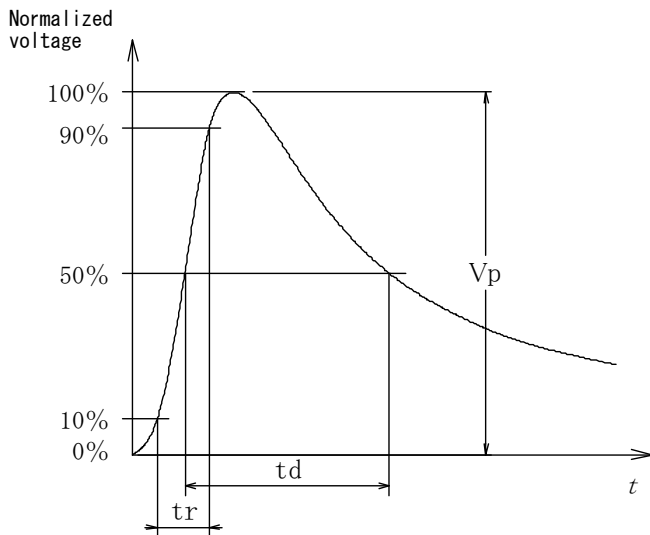

Fig. 8-2 Single pulse waveform

- 50Ω load
 - Vp : peak voltage (set voltage / 2) ± 10%
 - tr : rise time 5ns ± 30%
 - td : pulse width 50ns ± 30%

- 1kΩ load
 - Vp : peak voltage (set voltage) ± 20%
 - tr : rise time 5ns ± 30%
 - td : pulse width 35ns ~ 150ns

8-5. Example of Test

IEC 61000-4-4 prescribes test to check immunity of EUT against burst noise occurred in various kind of situation e.g. on cutoff of electromagnetic switches. Burst noise is applied to EUT via power lines or signal lines. For details of IEC 61000-4-4, refer to the standard original.

Example of Test to Power Line

- 1.** Put the Unit (FNS-AX3) on ground plane (ground reference plane) which is connected to protective earth and connect SG terminal of the Unit to ground plane.
- 2.** Put a 10cm-thick insulation support on ground plane and put EUT on it (EUT is insulated from ground plane).
- 3.** Supply power for EUT to the Unit. Form the Unit to EUT, use 50cm cable to supply power. The figure as below shows the example of test for single-phase power line with using FNS-AX3 A16C.
- 4.** Set conditions (e.g. applying voltage) and start the test.

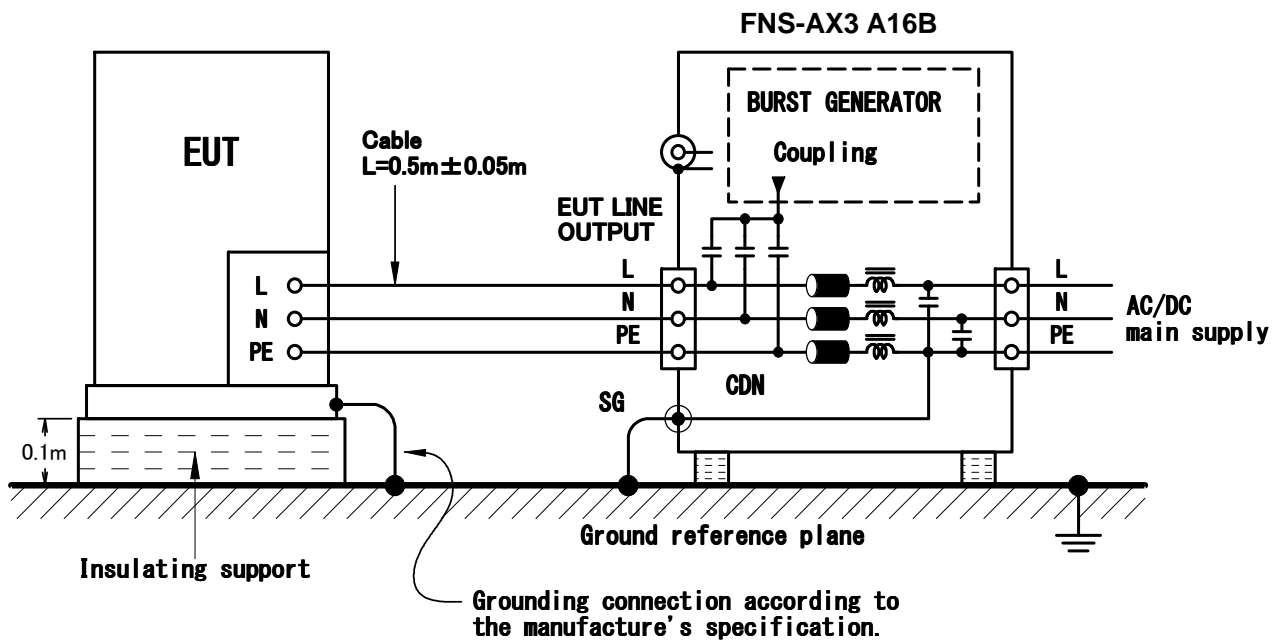

Example of Test to Signal Line

- 1.** Put the Unit (FNS-AX3) on ground plane (ground reference plane) which is connected to protective earth and connect SG terminal of the Unit to ground plane.
- 2.** Set coupling clamp on ground plane and connect GND of coupling clamp to ground plane.
- 3.** Connect coupling clamp to pulse out connector of the Unit.
- 4.** Pass a cable through coupling clamp. Adjust coupling clamp to maximize coupling capacitance (minimize the distance between the cable and coupling clamp).
- 5.** Put a cover of coupling clamp to prevent an electric shock, set conditions (e.g. applying voltage) and start the test.

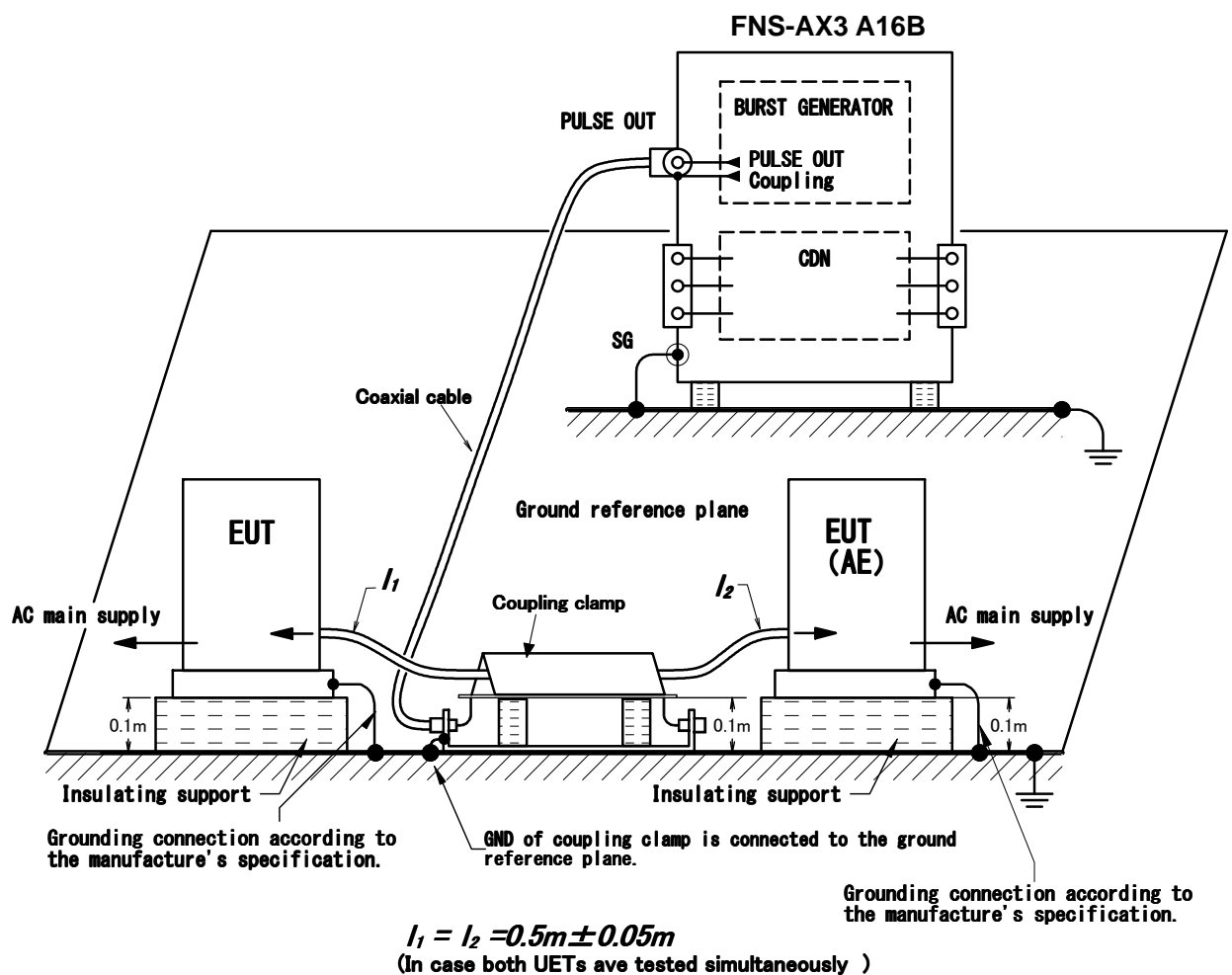

9. APPEARANCE AND FUNCTION OF EACH PART

9-1. Appearance of The Main Unit

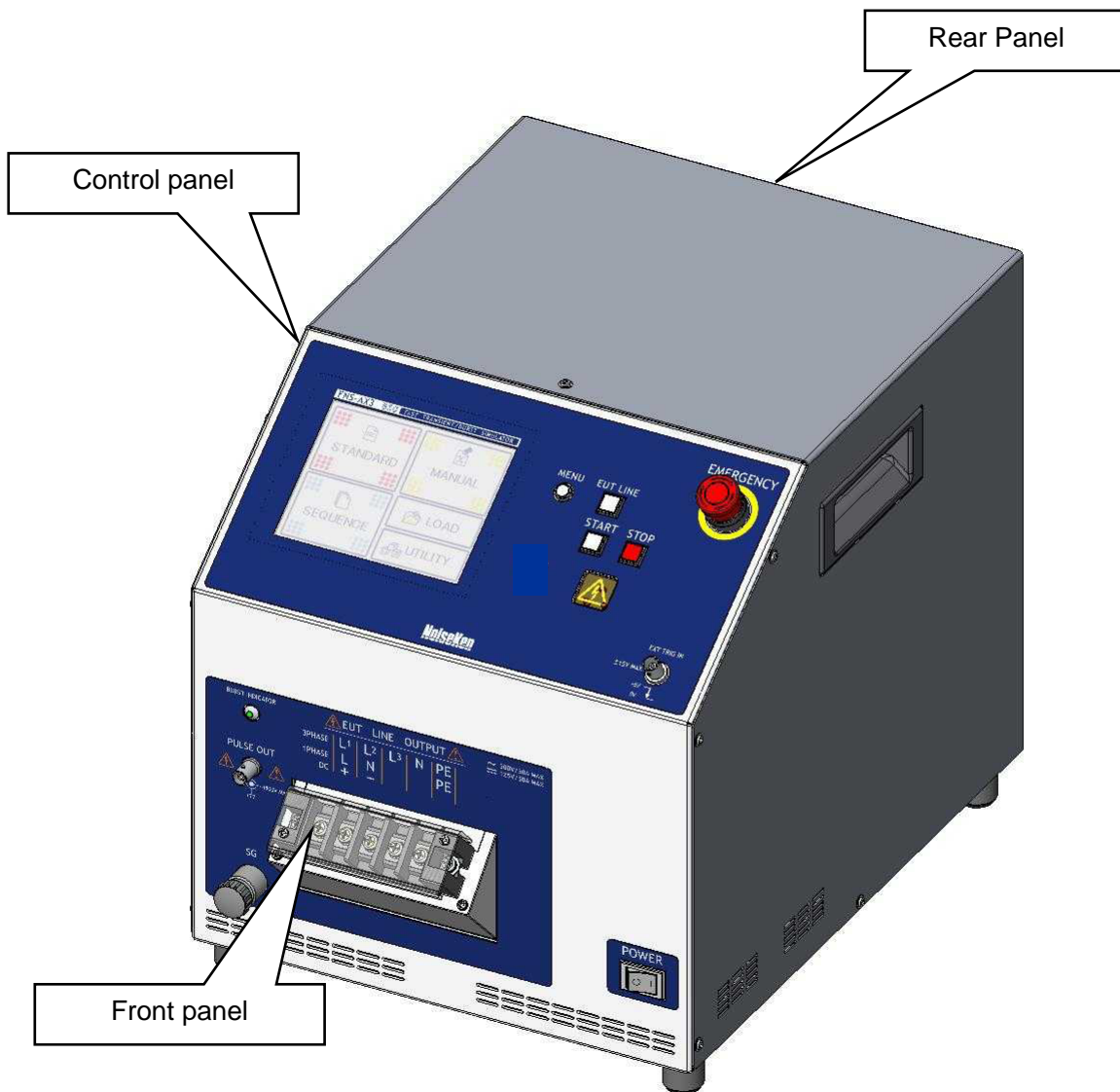

The figure is FNS-AX3 B50C.

9-2. Control Panel

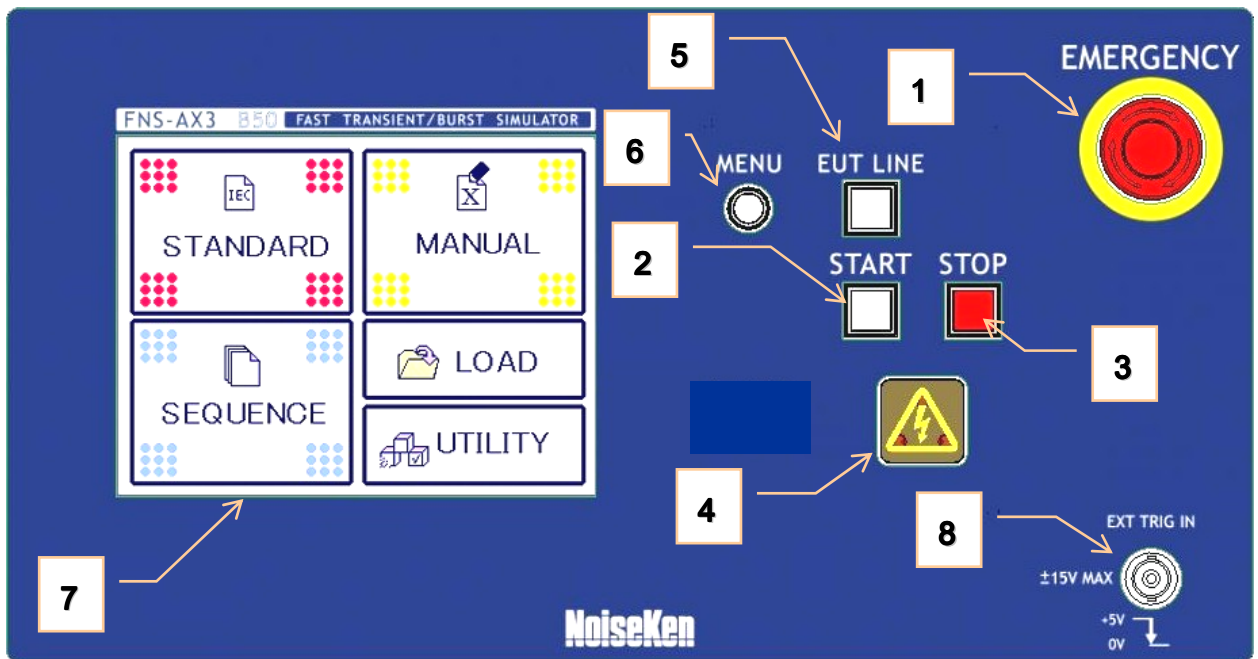

1. Emergency stop button 【EMERGENCY】
Stop button for emergency. Avoid using this button for ordinary stop.
2. START switch 【START】
Used to start a test. Starting is available when a lamp of switch is blinking.
3. STOP switch 【STOP】
Used to stop a test.
4. Warning lamp
Blinking while a test is being performed. As high voltage pulses are generated while this lamp is blinking, carefully handle the Unit.
5. EUT LINE switch 【EUT LINE】
Used to turn ON/OFF EUT LINE which is used for power line test.
Note) Status of EUT LINE will be held even after stopping test.
6. MENU switch 【MENU】
Used to indicate menu on LCD touch panel.
Note) This operation is not effective while conducting test.
7. LCD touch panel
Used to select mode and set up conditions.
8. External trigger input connector 【EXT TRIG IN】
BNC coaxial connector for inputting external signal.

9-3. Front Panel

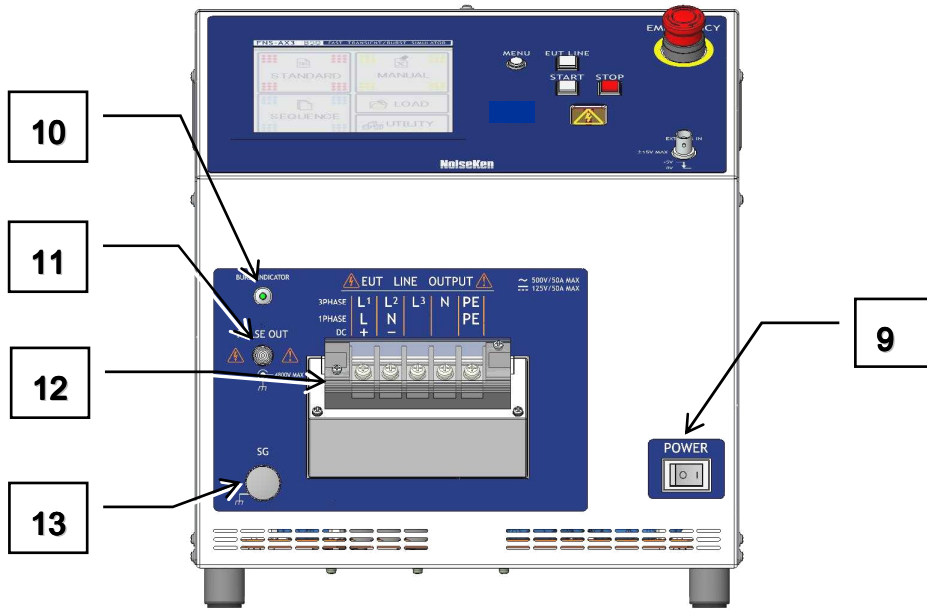

9. POWER switch 【POWER】
Used to turn ON/OFF the Unit, turn to (I) side for ON, (0) side for OFF.

10. Burst output indicator 【BURST INDICATOR】
Turns on a light while testing with sensing internal generation circuit.

 In some cases the indicator may not turn on according to conditions of burst or a connected load. Even though the indicator turns on a light, the indication does not always guarantee the Unit to apply right output.

11. Pulse out connector 【PULSE OUT】
Coaxial connector outputting high voltage pulse. Coupling clamp is connected to this connector.

 High voltage pulse is output on test. Mishandling or careless operation may result in a fatal wound. Carefully handle it.

12. EUT line output terminal block 【EUT LINE OUTPUT】
EUT line output terminal of L1/L2/L3/N/PE(B50C) or L/N/PE(A16C).

 High voltage pulse and power for EUT are output on test. Be sure to install protection cover after completing connection. Mishandling or careless operation may result in a fatal wound. Carefully handle it.

13. SG terminal 【SG】
Signal ground which becomes a return loop of high voltage pulse. Connect it to ground plane with the attached SG cable.

9-4. Rear Panel

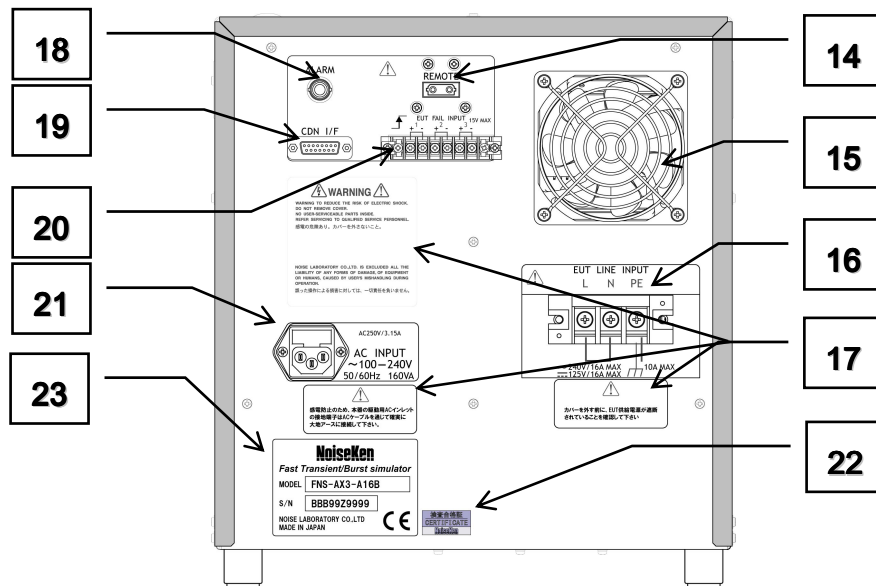

- 14. Optical communication connector 【REMOTE】**
An extension connector for future options.
- 15. Fan**
Used to radiate internal heat. Avoid blocking ventilation.
- 16. EUT line input terminal block 【EUT LINE INPUT】**
Terminal block used for inputting power supply for EUT.
EUT line of the Unit does not have any protection circuit against over voltage or over current.
Prepare a proper protection circuit separately.
- 17. Warning on handling**
Draws your attention to such points as “exemption from responsibility”, etc.
- 18. Warning light connector 【ALARM】**
Used to connect the optional warning light.
- 19. External CDN control connector 【CDN I/F】**
An extension connector for future options.
- 20. EUT FAIL input terminal block 【EUT FAIL INPUT】**
Inputs signals detecting EUT FAIL (malfunction). When a signal is detect, the Unit will work according to directions set up previously (e.g. stopping test, shutdown of EUT line, etc.).
- 21. AC inlet (with fuse) 【AC INPUT】**
Input connector for power supply of the Unit, incorporating fuse.
In exchanging fuses, prepare a fuse rated 250V F 2A.
- 22. Inspection certificate label**
Certifies that the Unit passed our inspection on shipment.
- 23. Serial number label**
Indicates serail number of the Unit.

10. CONNECTION

10-1. Connecting AC Cord

Insert a proper AC cord into AC inlet 【AC INPUT】 .

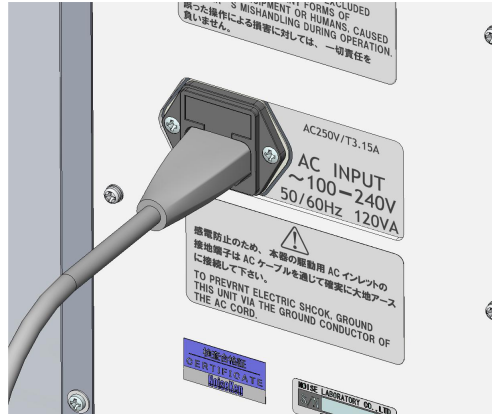

The attached AC cord is for AC100~120V. In case of AC220~240V, prepare a 3-line AC cord with PE terminal pin which is conforming to the local safety standard.

10-2. Connecting Ground Plane

Connect SG terminal 【SG】 to ground plane with the attached SG cable. Connect the cable to the terminal and tighten the knob securely to fix. If EUT has an earth terminal, connect EUT to ground plane according to the manufacturer's specification.



In case that the attached cable is too short to connect to ground plane, preparing another cable does not matter, but it is necessary to make the cable as short as possible. The IEC standard does not describe any specific length of SG cable, but has a description “the connection impedance of the coupling/decoupling network earth cables to the ground plane and all bonding shall provide a low inductance.”

10-3. Connecting Line Input

Connect EUT power supply to the Unit.



- Prepare a plus driver and EUT LINE input, output cables.
- EUT line of the Unit does not have any protection circuit against over voltage or over current. Prepare a proper protection circuit separately.
Line ratings A16C : AC240V/16A, DC125V/16A
B50C : AC500V/50A, DC125V/50A

- 1.** Make sure that power supply to EUT is cut off and the Unit is in OFF status.
- 2.** Remove the protection cover of LINE INPUT terminal block 【EUT LINE INPUT】 on the rear panel.
- 3.** Fix cables securely with a driver. Connecting points are dependent on the model number of the Unit and the kind of EUT power supply. Refer to figures on the next page.
- 4.** Install the protection cover.



In case of using 3-phase CDN type (B50C) for single-phase or DC line, connect cables according to the indication 【1PHASE】 on the panel.

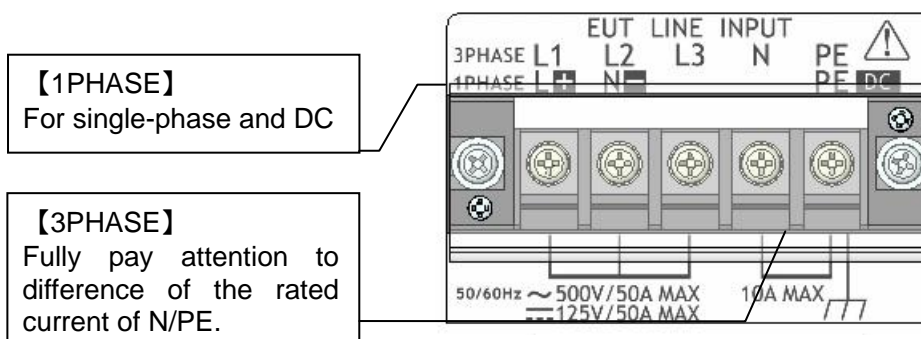

FNS-AX3 A16C

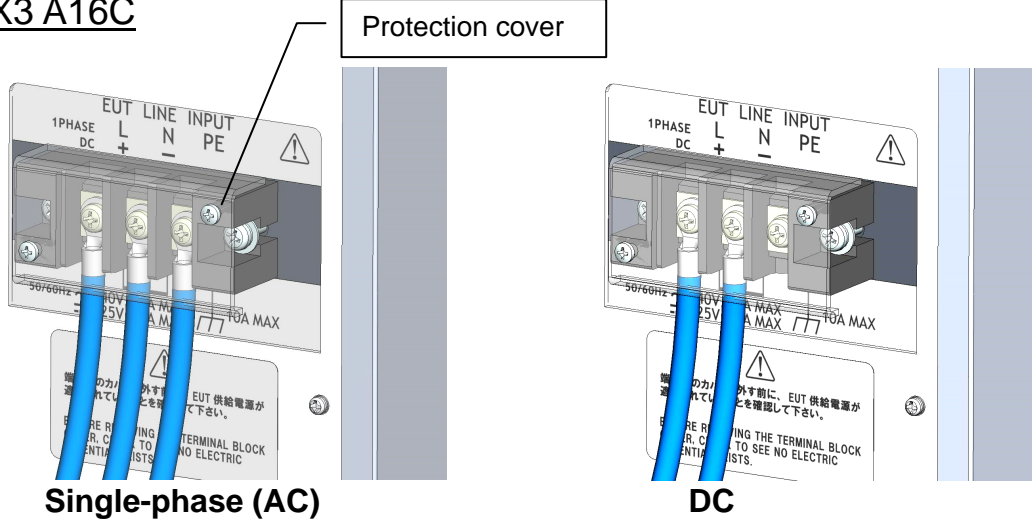

FNS-AX3 B50C

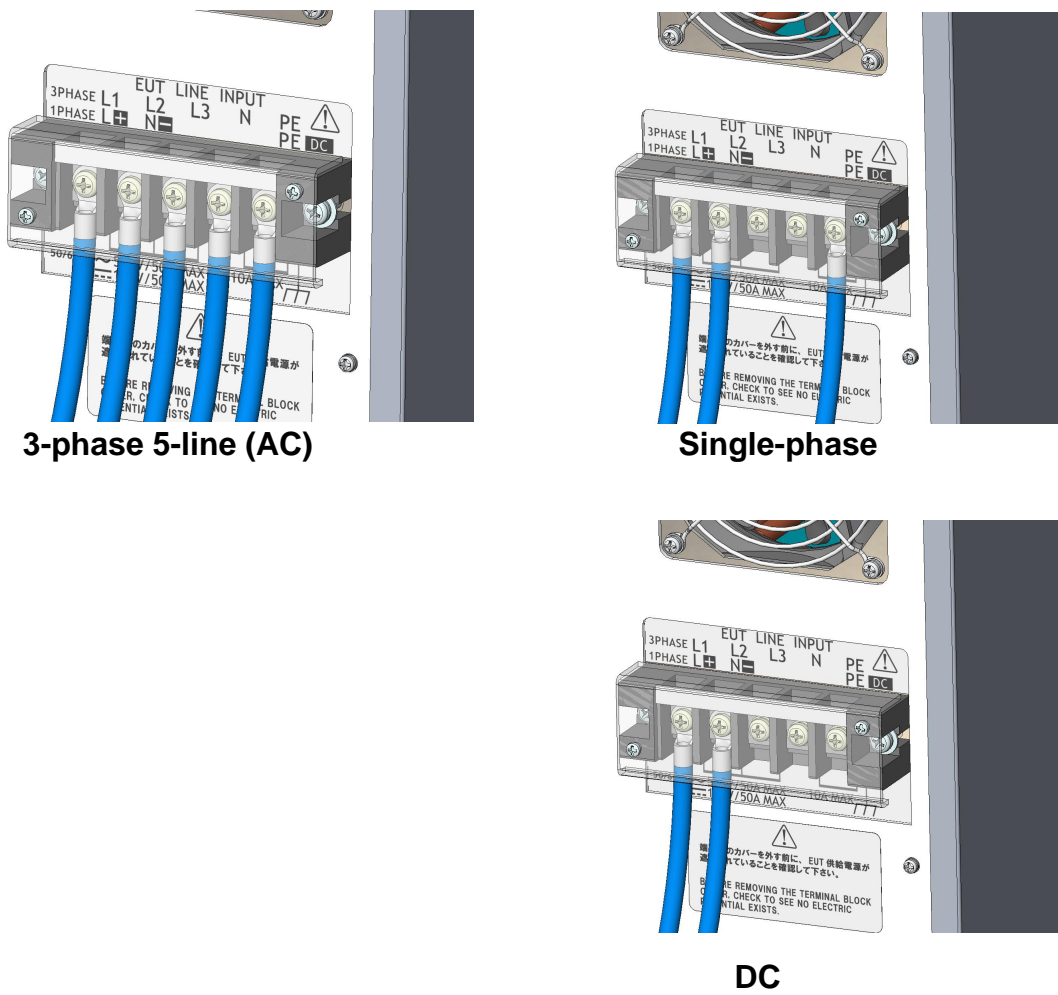

10-4. Connecting Line Output (Power Line)

Connect line output cables. The points to be paid attention to are the same as connection of line input. Follow the instruction on the panel of the Unit.

- 1.** Make sure that power supply to EUT is cut off and the Unit is in OFF status.
- 2.** Remove the protection cover of LINE OUTPUT terminal block 【EUT LINE OUTPUT】 on the front panel.
- 3.** Fix cables securely with a driver. Connecting points are dependent on the model number of the Unit and the kind of EUT power supply. Refer to figures as follows.
- 4.** Install the protection cover.

FNS-AX3 A16C

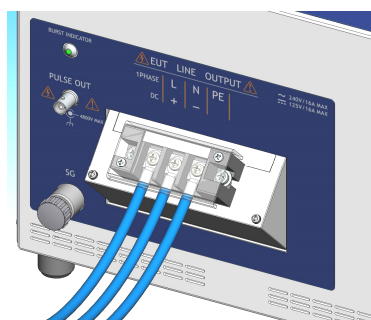

Single-phase (AC)

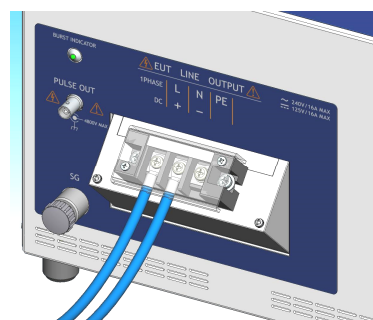

DC

FNS-AX3 B50C

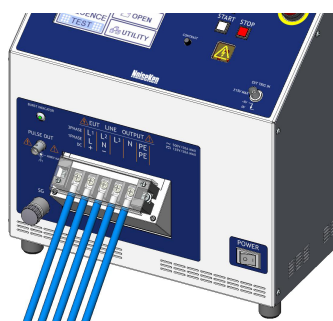

3-phase 5 line(AC)

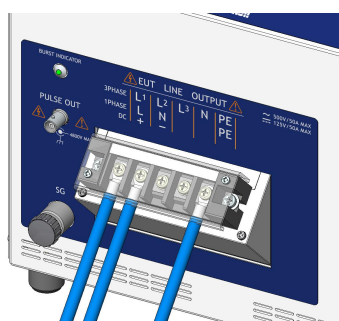

Single-phase

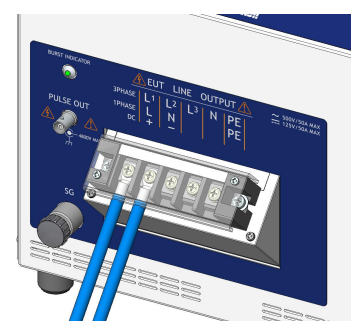



DC

10-5. Connecting Coupling Clamp

Connect coupling clamp (option) to the Unit. For configuration of equipment, refer to the instruction manual of coupling clamp.

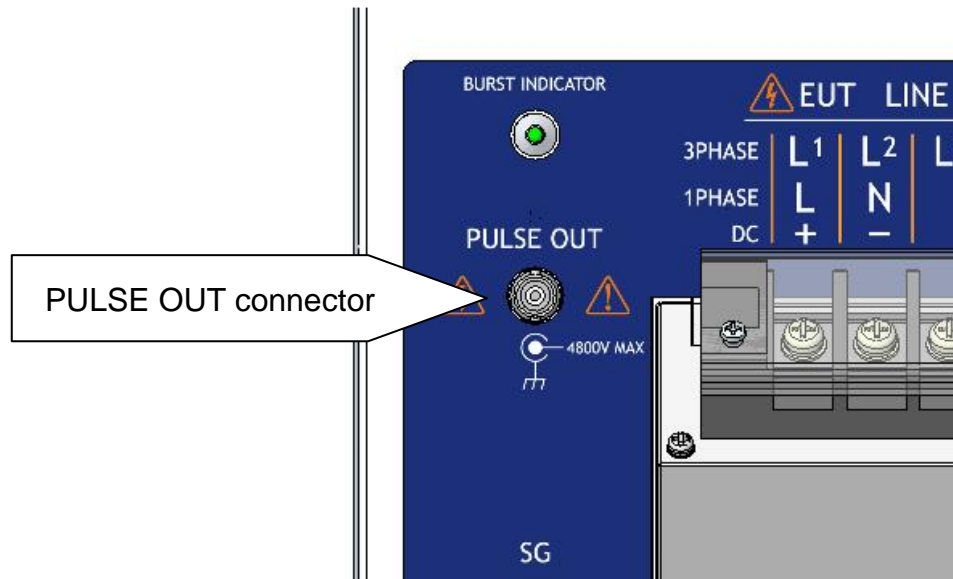
- 1.** Make sure that the Unit is in OFF status.
- 2.** Connect the coaxial cable of the coupling clamp to pulse out connector 【PULSE OUT】 on front panel of the Unit.



 For connection, use the coaxial cable attached to the coupling clamp as an accessory. PULSE OUT connector is a specially-developed connector to withstand high voltage, not BNC connector.

WARNING

High voltage pulse is output.

Mishandling or careless operation may result in a fatal wound. Carefully handle it.

11. OPERATION

11-1. Turn ON FNS-AX3

1. Turn on the Unit with POWER switch on front panel of the Unit.

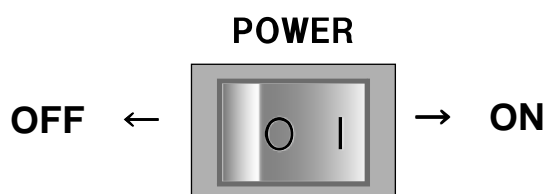

2. When the Unit is turned on and starts normally, an electronic sound goes off, main menu is displayed on LCD touch panel, and a fan in rear side starts working.

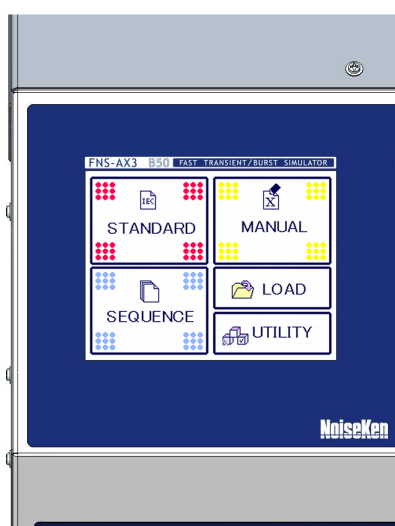

Main menu is displayed as default when the Unit is first turned on after shipment. The screen displayed when the Unit is turned on can be set on "UTILITY" screen. Refer to 15. UTILITY.

11-2. Emergency Stop Button

Emergency stop button is just for emergency. Do not use it to stop usual operation.



When emergency stop button is pressed, the Unit shifts to the following status forcibly.

- The test is immediately stopped and high voltage generating circuit of the Unit is turned off.
- EUT power supply (EUT LINE switch) is turned off by force.

When emergency stop button is pressed, operation is prohibited until the Unit is turned on again.

The following error message is displayed on operation screen.

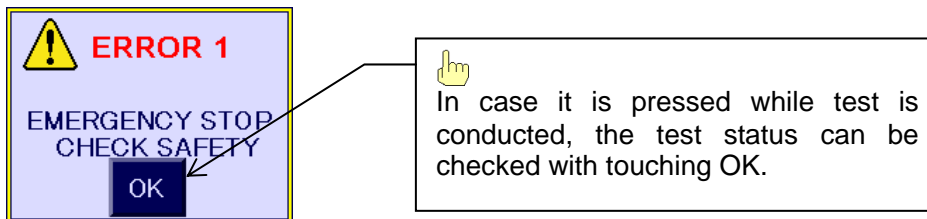

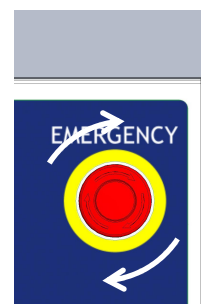

Release emergency stop status as following procedure.

- 1.** Turn off the Unit with POWER switch of the Unit.
- 2.** Rotate emergency stop button clockwise to release the status.



- 3.** Turn on the Unit again with POWER switch.

 In releasing emergency stop status and turning on the Unit again, remove the cause of pressing emergency stop button and ensure safety fully.

 If emergency stop status is released when POWER switch of the Unit is ON, every operation is prohibited until the Unit is turned on again.

11-3. Main Menu

The Unit adopts touch panel type LCD which enables image-oriented operation with graphic display. When main menu is displayed, touch the panel to select a function to be used.

As main menu is always displayed when MENU switch is pressed, moving to another screen is easy. (This function is unavailable while conducting test.)

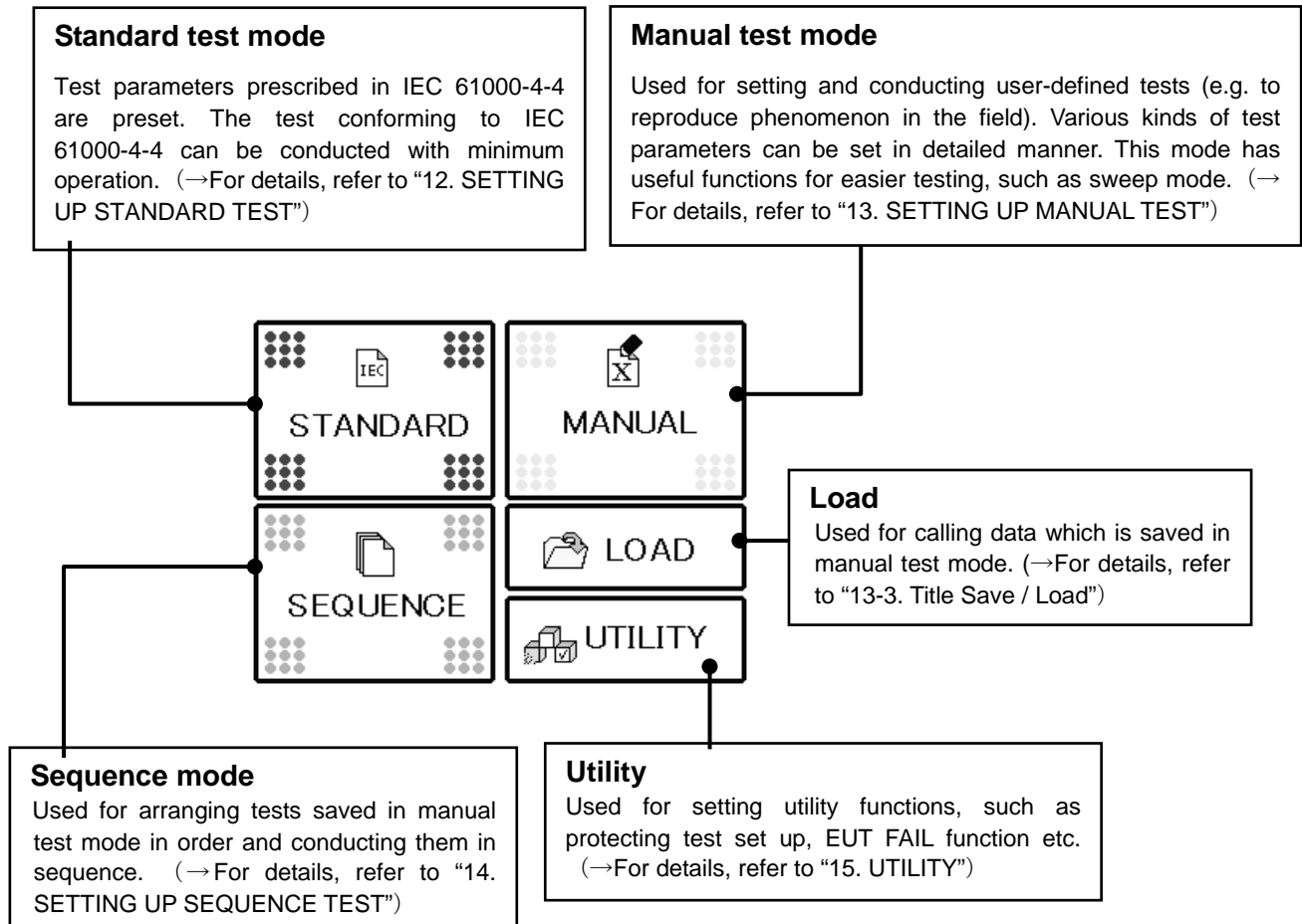

11-4. Screen Flowchart

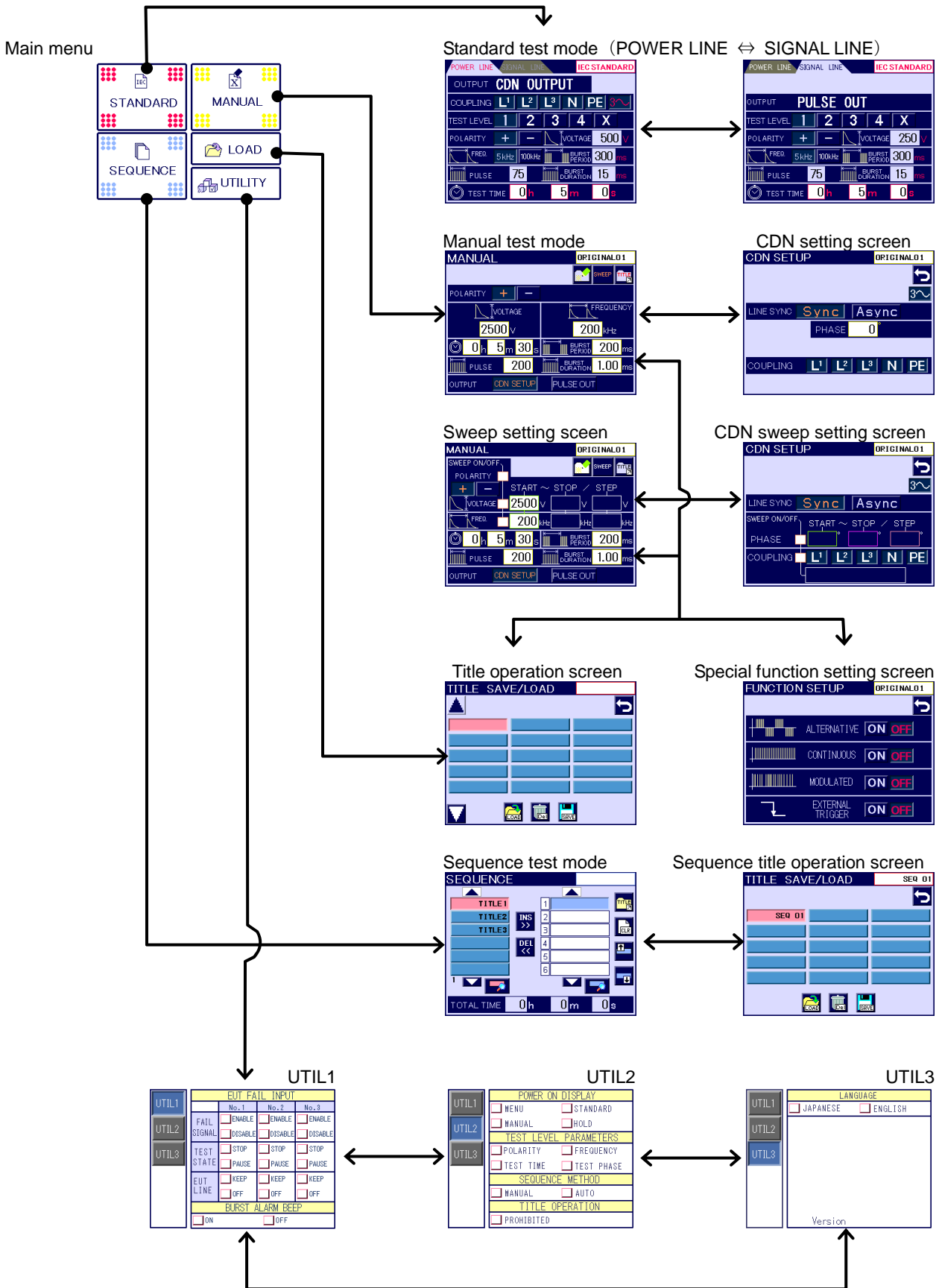

11-5. Inputting Numbers and Letters (About Ten Key and Character Key)

Ten key is displayed for inputting numbers, character key is displayed for operation for title. Basic operations of them are as follows.

Touch the item to be input to display ten key. Ten key will be displayed with the value as before.

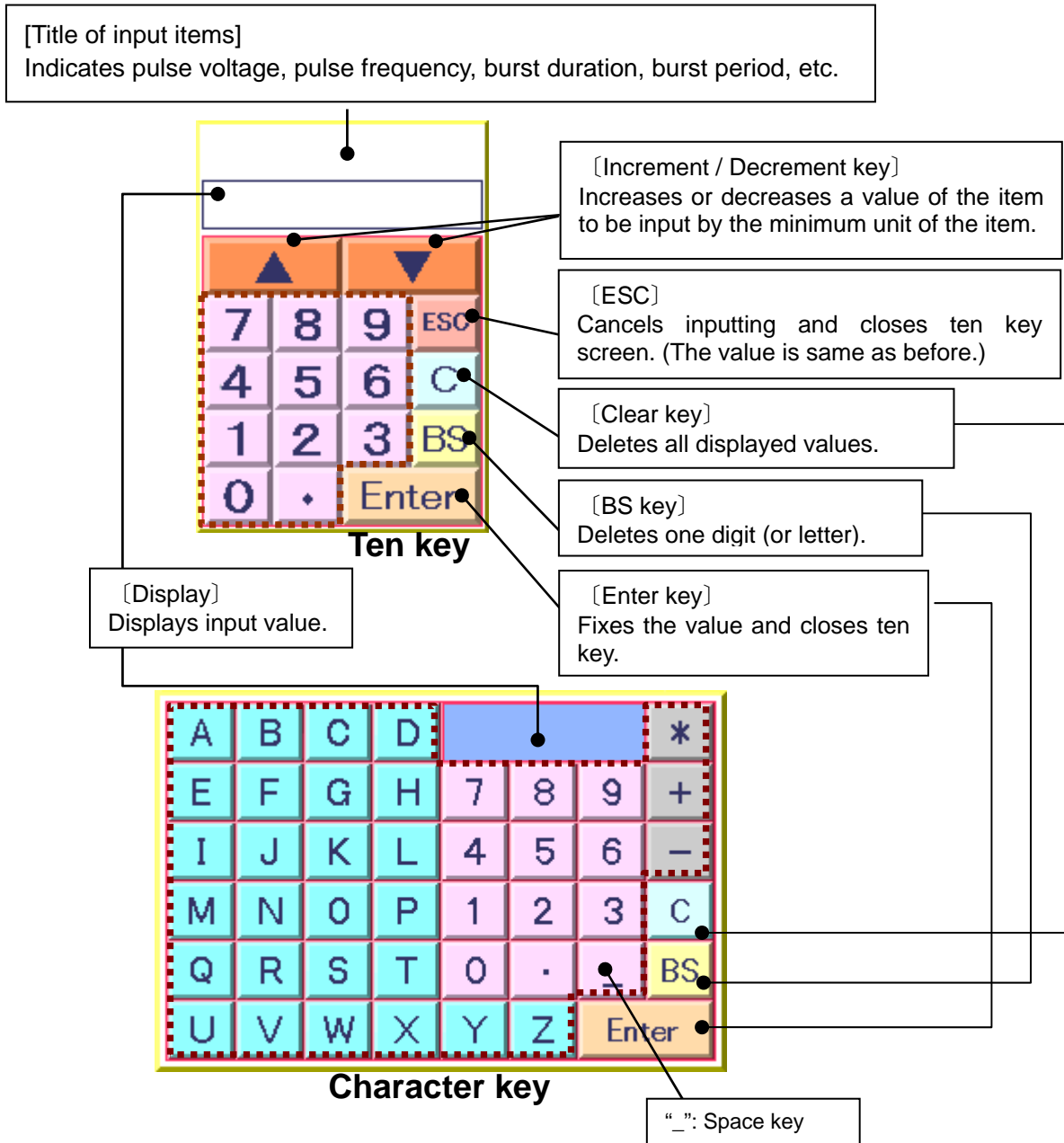

12. SETTING UP STANDARD TEST

 Touch 『STANDARD』 on main menu.

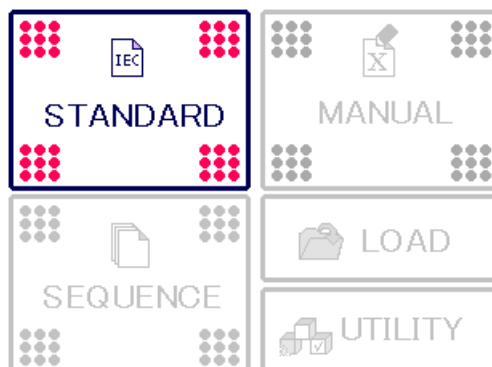

In Standard test mode, the test levels shown on Table 12-1, 12-2 are available. If any other test condition than followings is needed, set with Manual test mode.

Select 『POWER LINE』 to conduct tests using CDN for power lines or PE, and 『SIGNAL LINE』 to conduct tests using coupling clamp for I/O port, data port, or control port.

Table 12-1 Test set up for POWER LINE

For power line and protective earth						
Output to : Line output terminal 【CDN OUTPUT】						
TEST LEVEL	Polarity	Voltage	Pulse Frequency	Burst Duration	Pulse Counts	Burst Period
Level 1	+	0.5kV	5kHz	15ms	75	300ms
	-		100kHz	0.75ms	75	300ms
Level 2	+	1kV	5kHz	15ms	75	300ms
	-		100kHz	0.75ms	75	300ms
Level 3	+	2kV	5kHz	15ms	75	300ms
	-		100kHz	0.75ms	75	300ms
Level 4	+	4kV	5kHz	15ms	75	300ms
	-		100kHz	0.75ms	75	300ms

Table 12-2. Test set up for SIGNAL LINE

For I/O port, data port, and control port with using coupling clamp						
Output to : Pulse out connector 【PULSE OUT】						
TEST LEVEL	Polarity	Voltage	Pulse Frequency	Burst Duration	Pulse Counts	Burst Period
Level 1	+	0.25kV	5kHz	15ms	75	300ms
	-		100kHz	0.75ms	75	300ms
Level 2	+	0.5kV	5kHz	15ms	75	300ms
	-		100kHz	0.75ms	75	300ms
Level 3	+	1kV	5kHz	15ms	75	300ms
	-		100kHz	0.75ms	75	300ms
Level 4	+	2kV	5kHz	15ms	75	300ms
	-		100kHz	0.75ms	75	300ms



In set up items, “Test time”, “Polarity”, “Frequency”, and “Coupling phase” can be set independently. For details, Refer to “Setting up Common Items over Levels” (P.72) in “15. UTILITY”.

Output
Indicates which high voltage pulse outputs to, CDN or Pulse out.

CDN coupling
Selects which line high voltage pulse couples to. (This column is not indicated on SIGNAL LINE screen)

Test level
Touch test level. Select , , , , or .

Polarity
Touch or .

Pulse frequency
Touch or .

Parameters that are fixed with specifying voltage and frequency values are displayed here.

Standard test setting screen

The screenshot shows the 'Standard test setting screen' with the following parameters: **OUTPUT** (CDN OUTPUT), **COUPLING** (L¹, L², L³, N, PE), **TEST LEVEL** (1, 2, 3, 4, X), **POLARITY** (+, -), **FREQ.** (5kHz, 100kHz), **VOLTAGE** (500V), **BURST PERIOD** (300ms), **PULSE** (75), **BURST DURATION** (15ms), and **TEST TIME** (0h, 5m, 0s). The screen also has tabs for POWER LINE, SIGNAL LINE, and IEC STANDARD.

Test time
Touch Set test time with ten key.

Test time can be set from 1 second to 9 hours 59 minutes 59 seconds by 1-second step. Press each column to indicate ten key. Input test time and press Enter to fix the time.

⌚ (h)				
▲	▼			
7	8	9	ESC	
4	5	6	C	
1	2	3	BS	
0	.	Enter		

⌚ (m)				
▲	▼			
7	8	9	ESC	
4	5	6	C	
1	2	3	BS	
0	.	Enter		

⌚ (s)				
▲	▼			
7	8	9	ESC	
4	5	6	C	
1	2	3	BS	
0	.	Enter		

- If of test level is pressed, a message box asking whether moving to Manual test mode or not will appear. If 『yes』 is selected, the screen will move to Manual test setting screen with holding all data as is. This function is useful for making a new test format based on IEC test with changing some conditions of it.
- The pulse voltage is set according to the selected test level. The values of burst period, pulse counts, and burst duration are fixed on the values prescribed in IEC standard. Refer to Table 12-1 and Table 12-2.

Selecting Coupling Line

Select 『POWER LINE』 or 『SIGNAL LINE』 with tabs upper left on the screen.

Coupling high voltage pulse to power line (POWER LINE)

Touch 『POWER LINE』 upper left tab.

Pulse is set to output to line output terminal block on front panel 【EUT LINE OUTPUT】 .

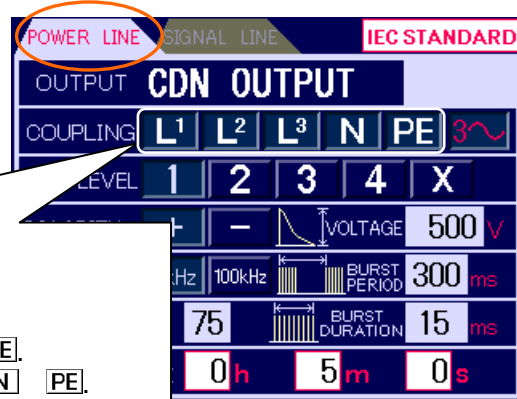

Touch the phase to be coupled.

Single-phase model (A16B): Select from L N PE.
 3-phase model (B50B): Select from L¹ L² L³ N PE.

Single-phase model A16C



3-phase model B50C

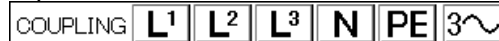

3-phase model B50C (Single-phase mode)



- Simultaneous coupling to all lines versus ground reference plane is prescribed in IEC 61000-4-4 Ed.2 and Ed.3. For CDN coupling, coupling to all lines is selected as a default value on shipment. Select coupling phase according to your test condition.
- In case of using 3-phase type B50C for single-phase test, touch to make B50C into single-phase mode. In such a case, be fully careful of connection of line input and line output.

Touch the icon to set up the screen precisely according to the actual connection. Refer to “10-3. Connecting Line Input” (P.27), “10-4. Connecting Line Output (Power Line)” (P.29).



At least one phase must be selected as the coupling phase.

Coupling high voltage pulse to signal line (SIGNAL LINE)

 Touch 『SIGNAL LINE』 upper left tab.

Pulse is set to output to pulse out connector on front panel 【PULSE OUT】 .

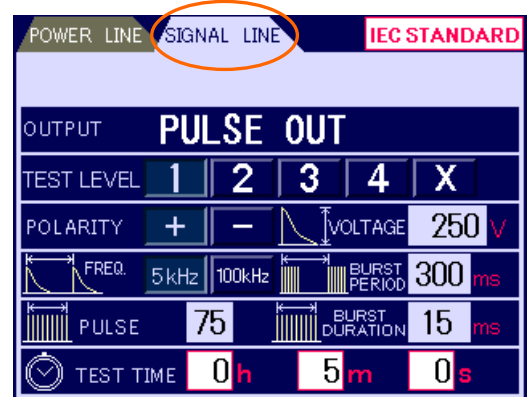

The optional coupling clamp is necessary for coupling to signal lines. For details, refer to “Example of Test to Signal Line” (P.21).

12-1. Executing Standard Test

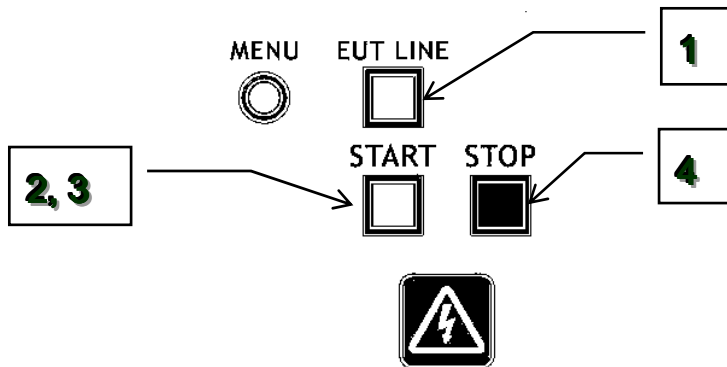

1. Power supply to EUT

In case of test to power line, press EUT LINE switch 【EUT LINE】 on control panel to connect the line. LED of EUT LINE switch is alight when power is supplied.



As power is supplied to line output terminal block 【EUT LINE OUTPUT】 when EUT LINE switch is turned ON, carefully handle the Unit and all related equipment.

2. Check screen

Press START switch to complete all conditions for test and to indicate the following check screen. Confirm the whole condition and press START switch again to start the test.

If is touched on check screen, the screen will return to Standard test setting screen.

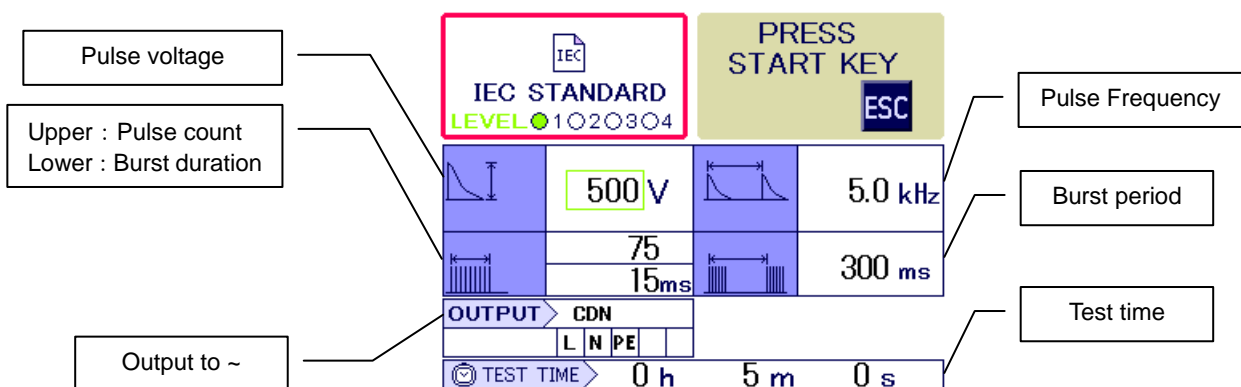

The indication of OUTPUT column depends on the selected test method. When POWER LINE is selected, 『CDN』 and phases to be coupled are indicated. When SIGNAL LINE is selected, 『PULSE OUT』 is indicated.

3. Conducting test

『UNDER TEST』 is indicated upper right on the screen. While test is being conducted, START switch is alight and warning lamp is blinking.



WARNING

High voltage pulses are output. Mishandling or careless operation may result in a fatal wound. Carefully handle it.

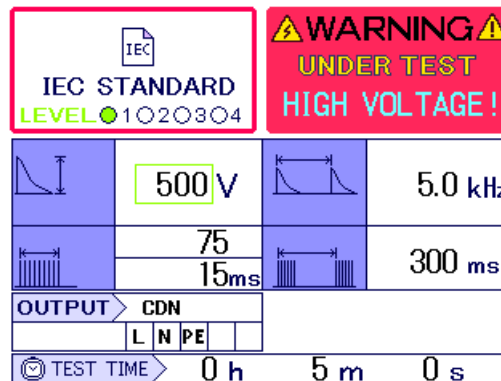

Pause

Pressing START switch while conducting test makes the output pausing. START switch is blinking and 『PAUSE』 is indicated upper right on the screen. For restarting the test, press START switch again.



If 『PAUSE』 status is left as is for 90 seconds, the test will be stopped automatically for safety.

Suspension

Pressing STOP switch while conducting test makes the test stop at the moment. START switch lights off and 『TEST suspended』 is indicated upper right on the screen.

👉 Confirming suspension, touch to return to Standard test setting screen.

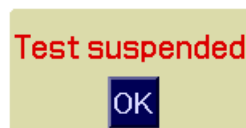

Starting test again on this screen is not available. For restarting, touch to return to Standard test setting screen and start again on that screen. When test is complete, the Unit provides a lag for eliminating electricity of the internal circuit. Elimination needs about 4 seconds. For safety, restarting is not available during that period. When test is complete, LINE switch is not turned off automatically. Turn off the switch manually.

4. Completion of test

Test is completed automatically when the set time has passed. START switch lights off and 『Test completed.』 is indicated upper right on the screen.

☞ Confirming completion, touch **OK** to return to Standard test setting screen.

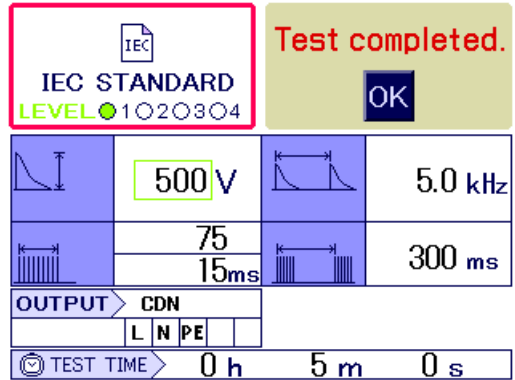

- Starting test again on this screen is not available. For restarting, touch **OK** to return to Standard test setting screen and start again on that screen. When test is complete, the Unit provides a lag for eliminating electricity of the internal circuit. Elimination needs about 4 seconds. For safety, restarting is not available during that period.
- In case of conducting test with LINE switch ON, when LINE switch is turned OFF, not only power supply is shut down, but also pulse generation is stopped.
- When test is suspended or completed, LINE switch is not turned off automatically. Turn off the switch manually.

Memorandum

13. SETTING UP MANUAL TEST

☞ Touch 『MANUAL』 on main menu.

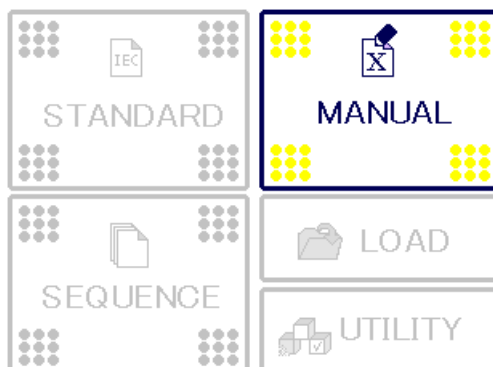

Title^{☆1}

Manual test setting screen

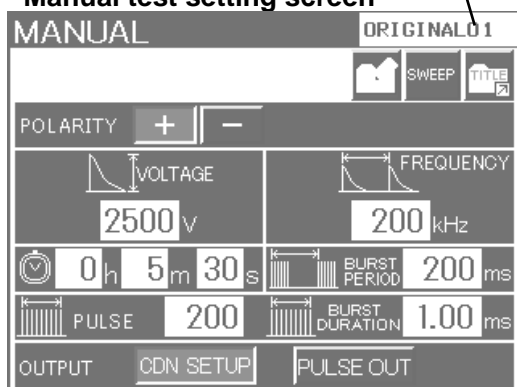

CDN setting screen

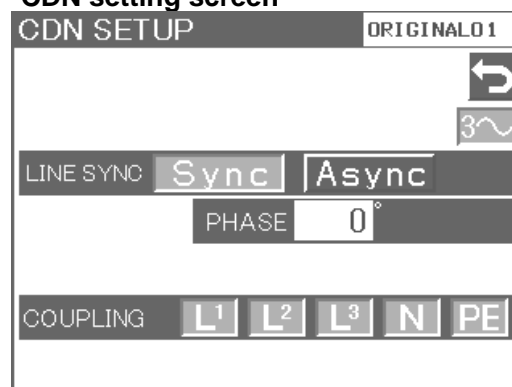

List of icons for operation

Icon of key	Remarks
 ↓ 	Used for setting up special function. If any special function is set, is indicated. →For details, refer to “13-2. Special Functions” (P. 52).
 ↓ 	Used for switching from one to another between Manual test setting screen and Sweep setting screen. If sweep function is set (<input checked="" type="checkbox"/> status), is indicated and the screen is fixed on Sweep setting screen. →For details, Refer to “13-1. Sweep Mode” (P. 51).
	Used for saving a set content under a title and for calling it again. →For details, refer to “13-3. Title Save / Load” (P. 57).
	Used for returning to Manual test setting screen or Sweep setting screen from CDN setting screen.
	Used for using 3-phase model as single-phase.

☆1 Title is indicated when the set up content is saved.

Selecting Polarity

Touch **+** or **-**.

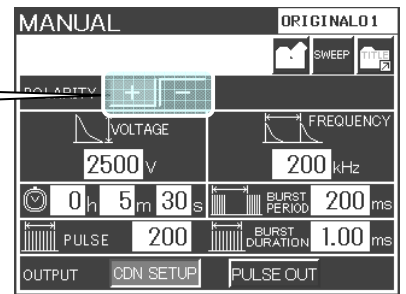

Setting Pulse Voltage

Touch the column of voltage. Input value and fix it with "Enter".

! 200V~4800V 10V step

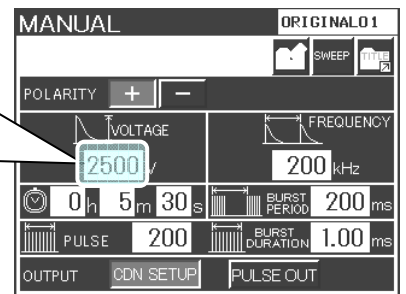
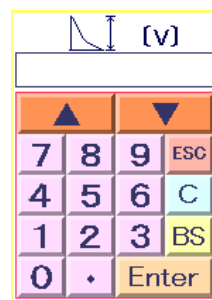

Setting Pulse Frequency

Touch the column of pulse frequency. Input value and fix it with "Enter".

!
0.1kHz~1.0kHz 0.01kHz step
1.0kHz~10kHz 0.1kHz step
10kHz~100kHz 1kHz step
100kHz~1000kHz 10kHz step
1000kHz~2000kHz 100kHz step

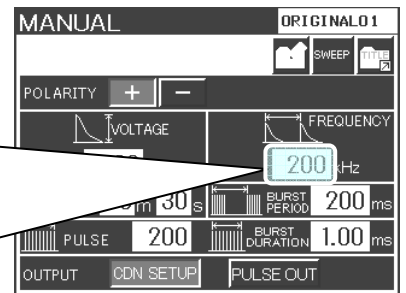
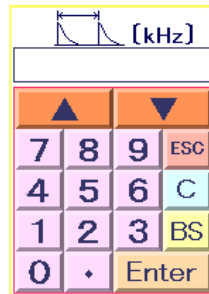

Setting Burst Period

Touch the column of burst period. Input value and fix it with "Enter".

! 10~1000ms 10ms step

In case of using alternate polarity function, the value should be less than 500ms.
 (For details of alternate polarity function, refer to P.54).

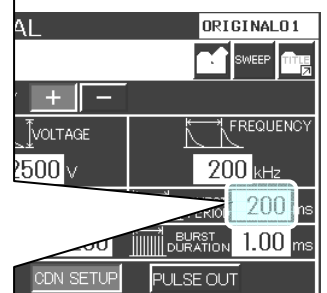
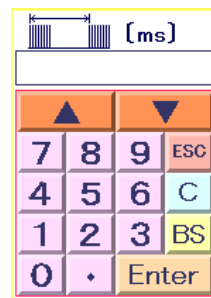

Setting Number of Pulse

 Touch the column of pulse count.
 Input value and fix it with "Enter".

 1~1000 1 step

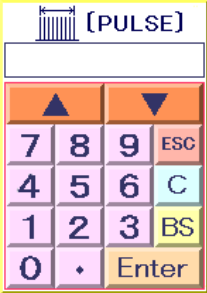
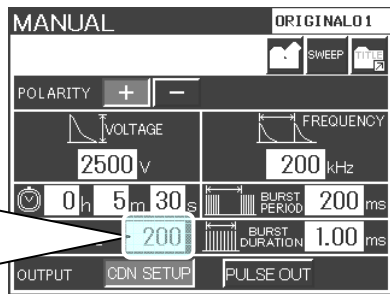



 The number of pulses (pulse count) is less than 1 piece of pulse per 1 ms of burst period.
 (If burst period is 300ms, the maximum number of pulses is 300pieces.)
 If burst duration is changed, pulse count will be recalculated.

Setting Burst Duration

 Touch the column of burst duration
 Input value and fix it with "Enter".

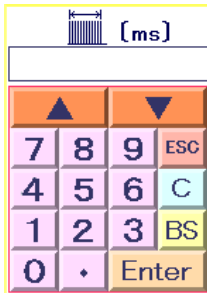
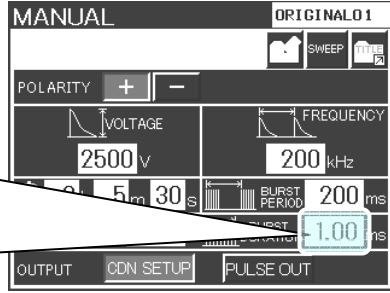
 0.01~999ms 0.01ms step

-  The number of pulses (pulse count) is the result of [burst duration] x [pulse frequency]. If the result of calculation is including fractions, it is recalculated automatically to make the pulse count an integral number. Therefore, note that the input value does not always become a set value. The result of calculation for pulse count is dealt with as an integral number with omitting decimals. The value of burst duration is always smaller than that of burst period.
- On the setting screen, the minimum value of burst duration is "0.01ms". If the set value is smaller than the minimum value, it is indicated as "0.01ms". If the value less than 0.01ms is necessary, use the way inputting from pulse count column.



Summary of setting burst

Pulse count is less than 1 per 1 ms of burst period.

Burst duration = Pulse count / Pulse frequency

Burst duration < Burst period

Ex. 1)

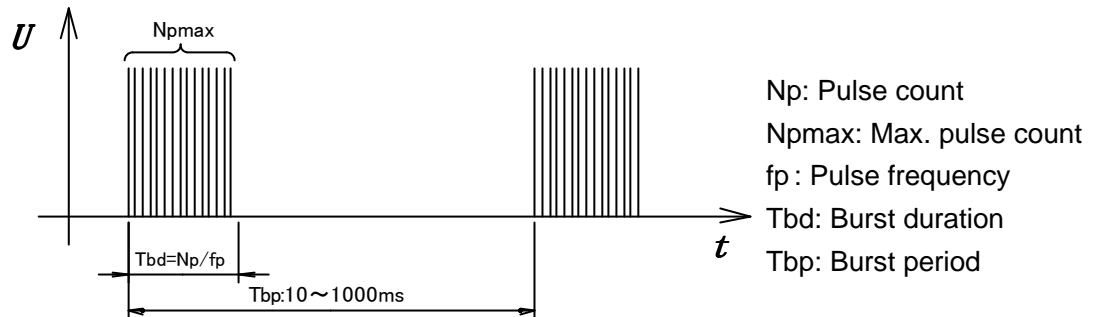

If pulse frequency is high enough (several kHz~), the maximum pulse count is the same number as the value of burst period.

Example) $T_{bd}=300ms$, Max. pulse count: 300

Ex. 2)

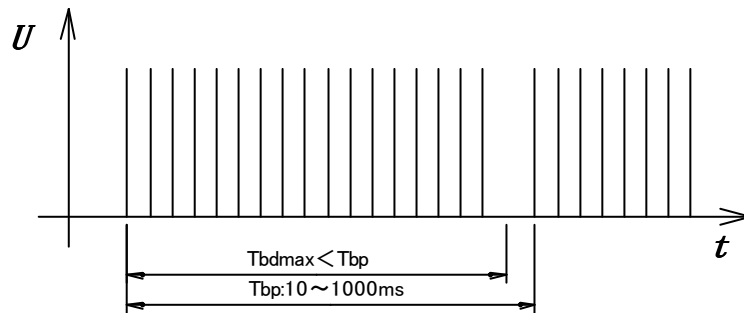

Burst duration (T_{bd}) cannot exceed burst period (T_{bp}).



The value and tolerance of the parameters prescribing output burst waveform (i.e. peak voltage, pulse frequency, burst duration, burst period, and characteristics of single pulse) are guaranteed with conditions described IEC 61000-4-4.

PULSE OUT waveform

Set voltage: $\pm 250V \sim 4000V$, Pulse frequency: 5kHz~100kHz

EUT LINE OUT waveform

Set voltage: $\pm 4000V$, Pulse frequency: 5kHz~100kHz

Selecting CDN Out or Pulse Out

Touch **CDN OUT** or **PULSE OUT**.
 If **CDN OUT** is touched, CDN setting screen is indicated.

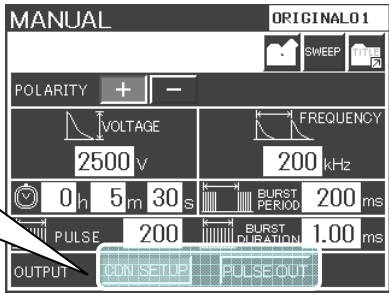

Setting Coupling Way for CDN Coupling

Touch **CDN OUT** to indicate CDN setting screen. On this screen, coupling phase and phase angle synchronization can be set.

If CDN is already selected and the setting screen is not indicated, touch **CDN SETUP** to indicate the CDN setting screen.

 A test cannot start from this screen.

Setting line phase angle synchronaization

If line synchronization is selected, the burst can be coupled with synchronizing AC line phase of EUT power supply. In the IEC standard, this test shall be conducted under “asynchronized” condition.

Touch **Sync** or **Async**.
 If **Sync** is selected, the column of phase angle is indicated.

Touch the column of phase angle.
 Input value and fix it with “Enter”.

 0~360° 1° step

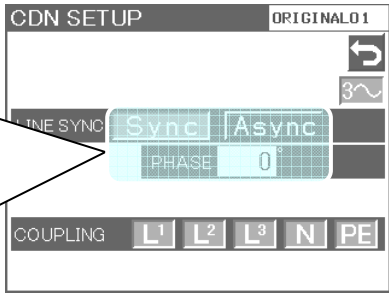
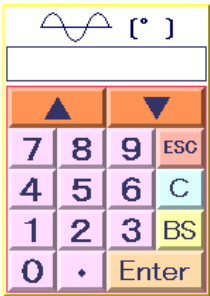

 The timing of burst output is the first specified phase angle after completing the former burst period. If burst needs to be output on every AC cycle, set 10ms for burst period. In this case, the maximum pulse count is 10 according to limitation of pulse count against burst period.

Example of AC line synchronized output (1)

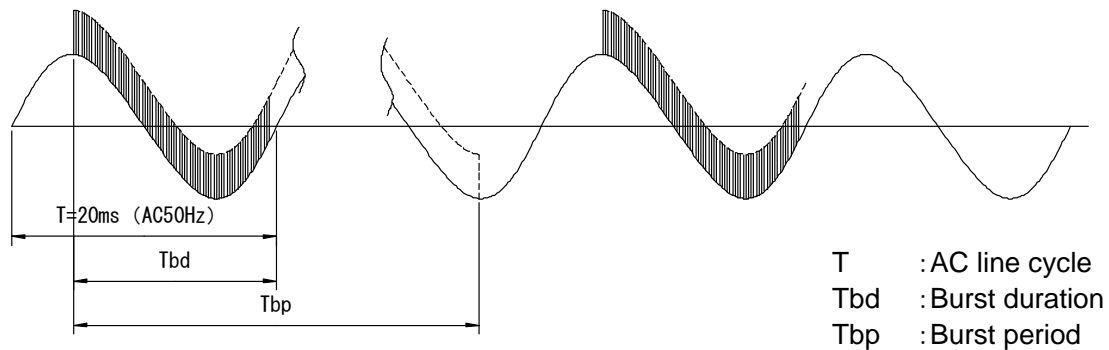
Phase angle: 90° 

After outputting under the condition of the specified burst duration and period, the next burst is output again on the next synchronized timing of AC line.

Example of AC line synchronized output (1)

Output burst on every AC cycle

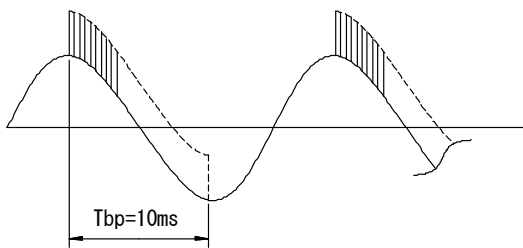
Phase angle: 90° 

Since the phase angle to be output burst synchronized AC line is based on the phase of L-N (A16C) or the phase of L1-L2 (B50C), If the ground reference plane is regarded as reference to **【EUT LINE OUT】**, N should be grounded in AC line input side in case of single-phase power supply, or L2 should be grounded in case of 3-phase to output burst synchronizing with AC line as shown in the above figures. (S should be grounded in case of 3-phase 3-line, etc.)

If your power supply is out of the above condition, synchronized output to AC line of the power supply regarding the ground reference plane as reference cannot be guaranteed.

If AC line synchronization has to be set precisely, ensure relationship between AC line waveform and burst output with measurement.

If the actual phase angle deviates from the set value, adjust the input value. When outputting any phase other than L (single-phase), outputting any phase other than L1 (3-phase), adjust the input value.

Setting CDN coupling phase

 Select phases to be coupled and touch the phase.

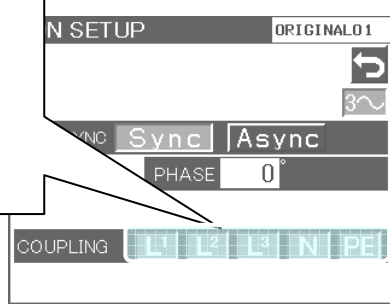

In single-phase model (A16B), select from **L** **N** **PE**.
 In 3-phase model (B50B), select from **L¹** **L²** **L³** **N** **PE**.



Single-phase model (A16C)
 COUPLING **L** **N** **PE**

3-phase model (B50C)
 COUPLING **L¹** **L²** **L³** **N** **PE**

3-phase model (B50C) (Single-phase mode)
 COUPLING **L** **N** **PE**

- Simultaneous coupling to all lines versus ground reference plane is prescribed in IEC 61000-4-4 Ed.2 and Ed.3. For CDN coupling, coupling to all lines is selected as a default value on shipment. Select coupling phase according to your test condition.
 - In case of using 3-phase type B50C for single-phase test, touch  to make B50C into single-phase mode. In such a case, be fully careful of connection of line input and line output.
-  Set up the screen precisely according to the actual connection. Refer to “10-3. Connecting Line Input” (P.27), “10-4. Connecting Line Output (Power Line)” (P.29).

 At least one phase must be selected as the coupling phase.

Setting Test Time

 Touch each column of test time to indicate ten key. Time form 1 second to 9 hours 59 minutes 59 seconds can be set at 1-second step. Input value and fix it with Enter.

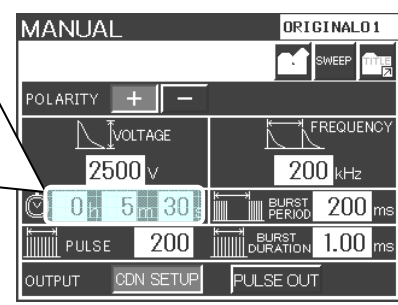
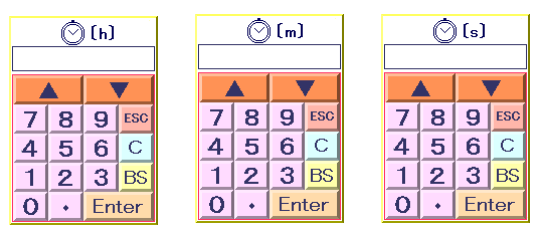

For conducting an actual test, refer to “13-4. Executing Manual Test (P. 60).

13-1. Sweep Mode

A test with using the sweep function is useful to check malfunction level of EUT because, with this function, tests can be conducted one after another with changing test parameters step by step and varying sets of polarity and coupling phase.

Touch  upper right on Manual test setting screen to indicate Sweep setting screen. On this screen, the sweep function of conducting a series of tests with varying polarity, pulse voltage, pulse frequency, coupling phase (only in case CDN OUT is selected), phase angle (only in case phase angle synchronization is selected) can be set. Input start value (START), stop value (STOP), and step value (STEP) to utilize the function. The order of executing each sweep is designated. Each sweep is executed in turn from lower level to upper of the flow chart as below. The series of tests completes with sweep of the voltage (uppermost in the flow chart). If sweep function is not used for one parameter, the value of the parameter is fixed.

Sweep setting screen

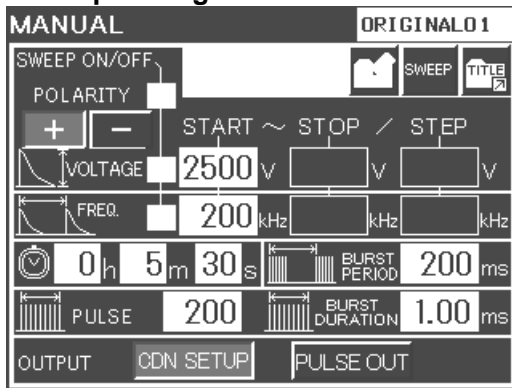

CDN sweep setting screen

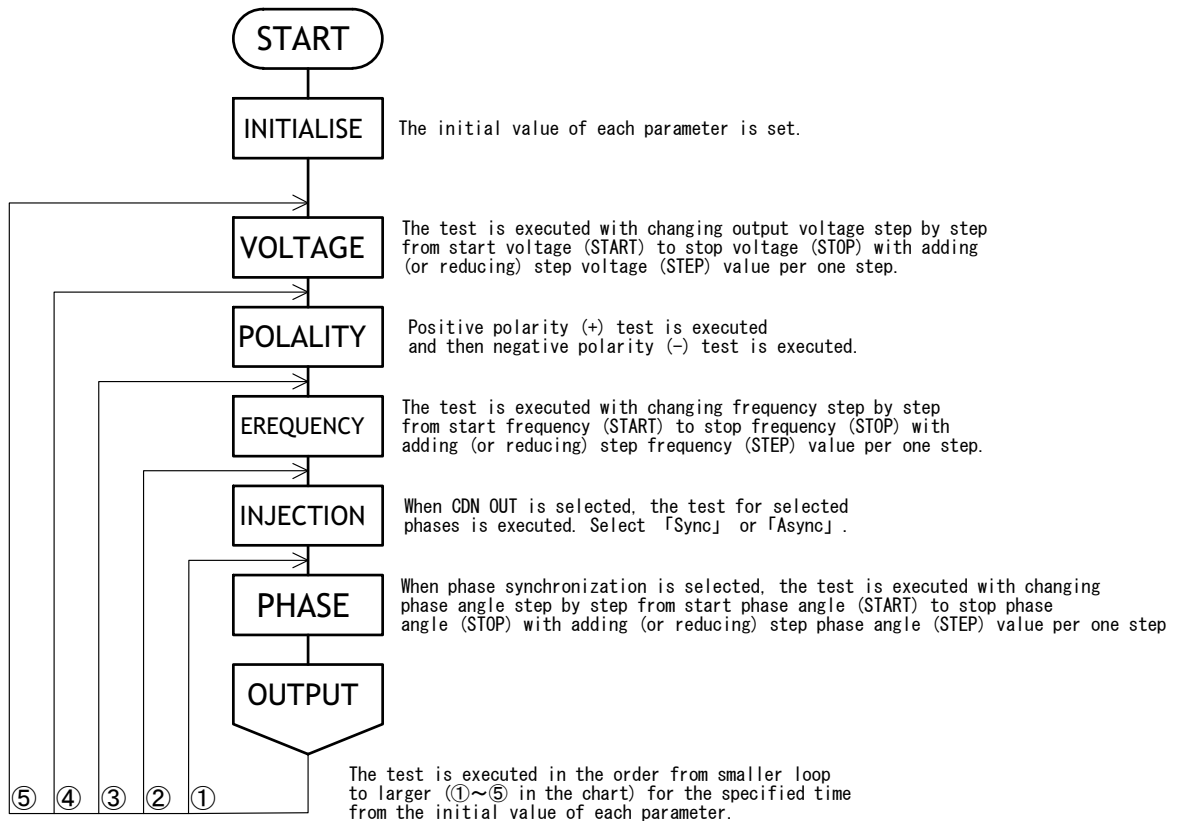
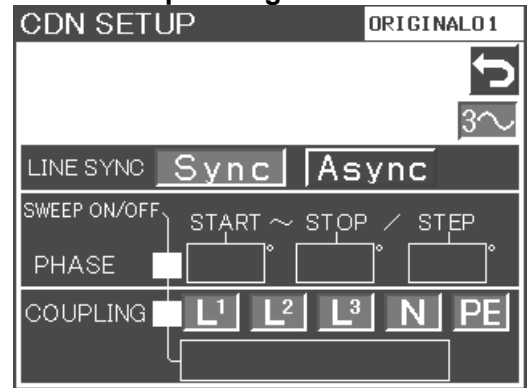

When the sweep function is set (status),  button turns to  and the screen is fixed on Sweep setting status.



In such cases like follows, the sweep function does not work. In case of start value (START)=stop value (STOP)=step value (STEP). In case that step value exceeds stop value.

Setting Polarity Sweep

If polarity sweep is set, the test is conducted in order of positive (+) → negative (-).

 Touch check box of polarity (☑).
To release the status, touch the box again or touch polarity button to select polarity.

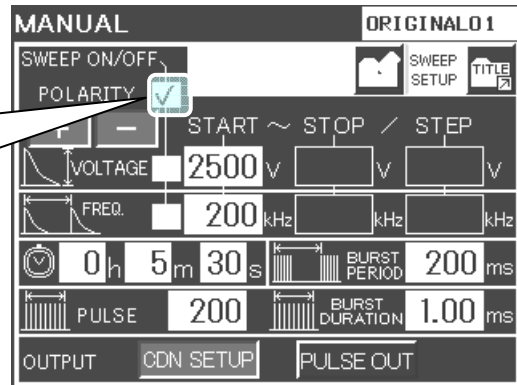

Setting Output Voltage Sweep

With the output voltage sweep function, the test is conducted with varying the output voltage from start voltage (START) to stop voltage (STOP) by step voltage (STEP) step.

 Touch check box of voltage (☑).
Columns of STOP and STEP are indicated. Touch each column to indicate ten key, input value, and fix it with Enter.
To release the status, touch the check box again.

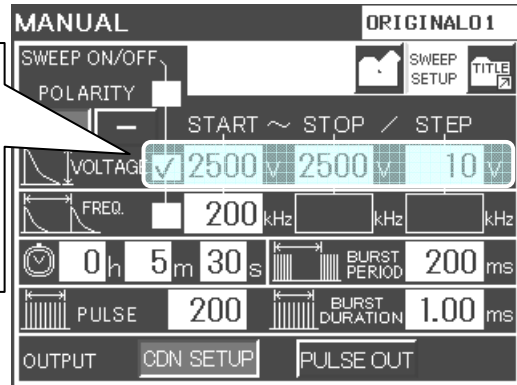

Setting Pulse Frequency Sweep

With the pulse frequency sweep function, the test is conducted with varying the pulse frequency from start frequency (START) to stop frequency (STOP) by step frequency (STEP) step.

 Touch check box of frequency (☑).
Columns of STOP and STEP are indicated. Touch each column to indicate ten key, input value, and fix it with Enter.
To release the status, touch the check box again.

 **!**

- 0.1kHz~1.00kHz: 0.01kHz step
- 1.0kHz~10.0kHz: 0.1kHz step
- 10kHz~100kHz: 1kHz step
- 100kHz~1000kHz: 10kHz step
- 1000kHz~2000kHz: 100kHz step

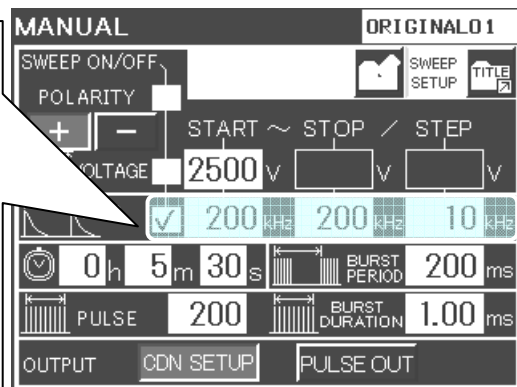

 **!** The pulse frequency sweep cannot be set over frequency ranges (Available within one frequency range). For sweeping over frequency ranges, make sequence execution list. → For details, refer to “14-1. Making Sequence Execution List” (P.65).

Setting CDN Sweep

Touch **CDN OUT** on Sweep setting screen to indicate CDN sweep setting screen. On this screen, line phase angle synchronization sweep and CDN coupling phase sweep can be set.

If CDN is already selected and the setting screen is not indicated, touch **CDN SETUP** to indicate the CDN setting screen.

Setting line phase angle synchronization sweep

With the line phase angle synchronization sweep function, the test is conducted with varying the phase angle from start phase angle (START) to stop phase angle (STOP) by step phase angle (STEP) step.

 Touch **Sync** to select synchronization mode. Touch check box of phase angle ().

Columns of STOP and STEP are indicated. Touch each column to indicate ten key, input value, and fix it with Enter.

If synchronization mode is not selected, check box of phase angle does not respond to your touch.

To release the status, touch the check box again.

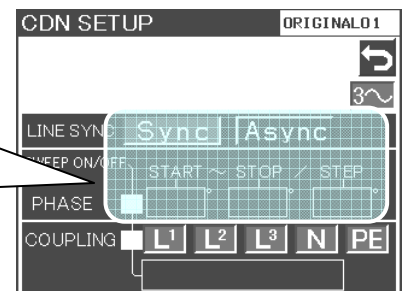

Setting CDN coupling phase sweep

With the CDN coupling phase sweep function, the test is conducted with varying the coupling phase, to specified each phase one after another, or to all combinations of specified phase. Selecting coupling to each phase (『LINE』) or to all combinations of phases (『ALL』) is available.

Ex.) In case L1/L2/L3 are selected

『LINE』 : Couples to L1 → L2 → L3 (each phase, step by step)

『ALL』: Couples to L1 → L2 → L3 → L1·L2→ L1·L3 → L2·L3 → L1·L2·L3 (All combinations including one phase only)

 Touch coupling phase to select.

In single-phase model (A16B), select from **L** **N** **PE**.

In 3-phase model (B50B), select from **L¹** **L²** **L³** **N** **PE**.

Touch check box of CDN coupling phase angle ().

LINE **ALL** are indicated. Select one of them.

To release the status, touch the check box again.

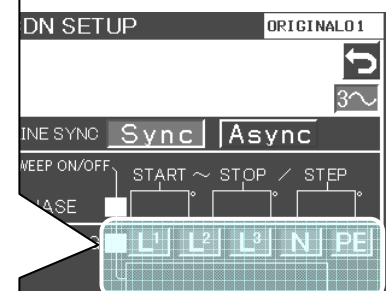





For conducting an actual test, refer to “13-4. Executing Manual Test (P. 60).”



13-2. Special Functions

A test with using special functions is effective to reproduce EUT's malfunctions in the field.

Touch  upper right on Manual test setting screen to indicate Special function setting screen. Some of functions cannot be set if conditions on the former screen are not enough.

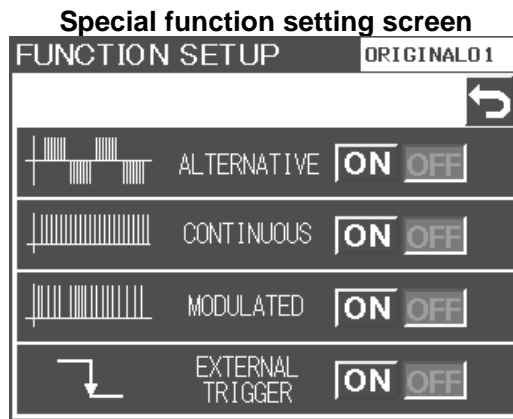
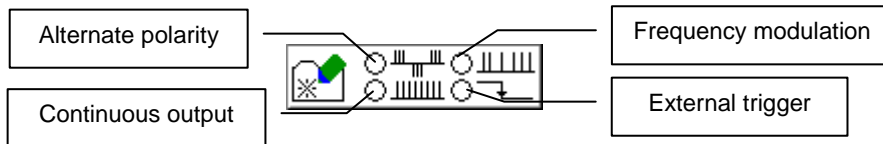
When the set up completes and the screen returns to Manual test setting screen,  turns to  and  of the set up item turns to .



 Starting test on this screen is not available. For starting, touch  to return to Manual test setting screen and operate there.

Setting Alternate Polarity

Burst can be output to positive and negative polarity alternately with the alternate polarity function.

 Touch ON/OFF of ALTERNATIVE.

The following conditions are necessary to make the alternate polarity function effective.

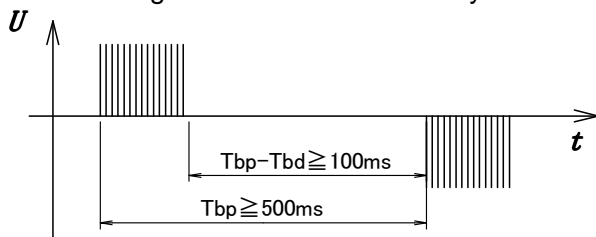

Tbd: Burst duration
Tbp: Burst period

- Burst period should be longer than 500ms.
- Burst resting period (Tbp-Tbd in the above) should be longer than 100ms.
- Test time should be less than 10 minutes.
- The function cannot be used with the continuous output function. "CONTINUOUS" should be OFF.

 If the alternate polarity function is turned ON previously, the above parameters will be limited. In some cases, even if values of burst period or burst duration are newly input, they are revised automatically by calculation because of the limitation.

Setting Continuous Output

Burst can be output continuously irrelevant to burst period with the continuous output function.

 Touch ON/OFF of CONTINUOUS.

The following conditions are necessary to make the continuous output function effective.

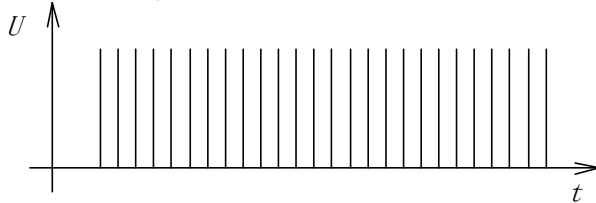

- Available pulse frequency is limited according to voltage value. Set them within the following range.

Voltage	Pulse frequency
200~1000V	Less than 10kHz
1010~2000V	Less than 4kHz
2010~4800V	Less than 1kHz

- Test time should be less than 10 minutes.
- The function cannot be used with the alternate polarity function. "ALTERNATIVE" should be OFF.
- The function cannot be used with the external trigger function. "EXTERNAL TRIGGER" should be OFF.



If the continuous output function is turned ON previously, the above parameters will be limited. In some cases, even if values of output voltage or pulse frequency are newly input, they are revised automatically by calculation because of the limitation.

Setting Frequency Modulation

Pulse frequency can sway within a range of about 10% of the set value with the frequency modulation function. As the swayed pulse frequency has less possibility to synchronize the clock of EUT than usual pulse frequency, it is more expected to reproduce EUT's malfunctions.

 Touch ON/OFF of MODULATED.

No condition is necessary to make the frequency modulation function effective.

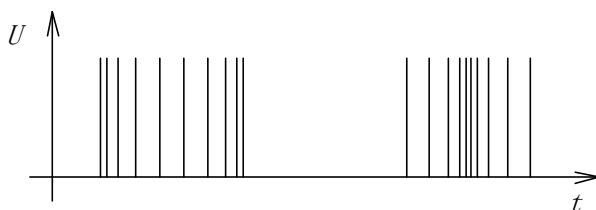

Setting External Trigger

Burst can be output synchronized with an external signal.

When a signal is input to the external trigger connector on control panel [EXT TRIG IN], the set burst is output.

 Touch ON/OFF of EXTERNAL TRIGGER.

The interface for inputting a trigger signal is shown on the figure as below.

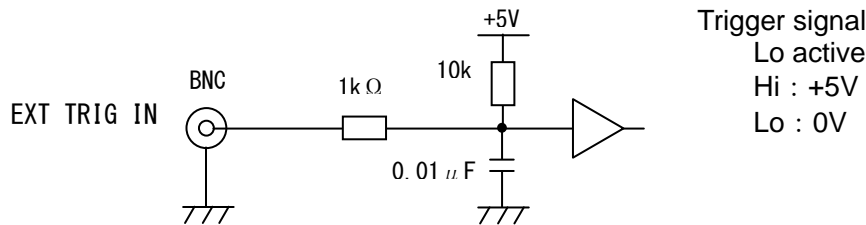



 As the trigger input terminal is pulled up to +5V internally, short-circuiting BNC connector for input can be a trigger signal.

The following figure shows timing of inputting trigger signals. A burst set previously is output every trigger signal.

Make Lo level period: $t \geq 50\text{ms}$.

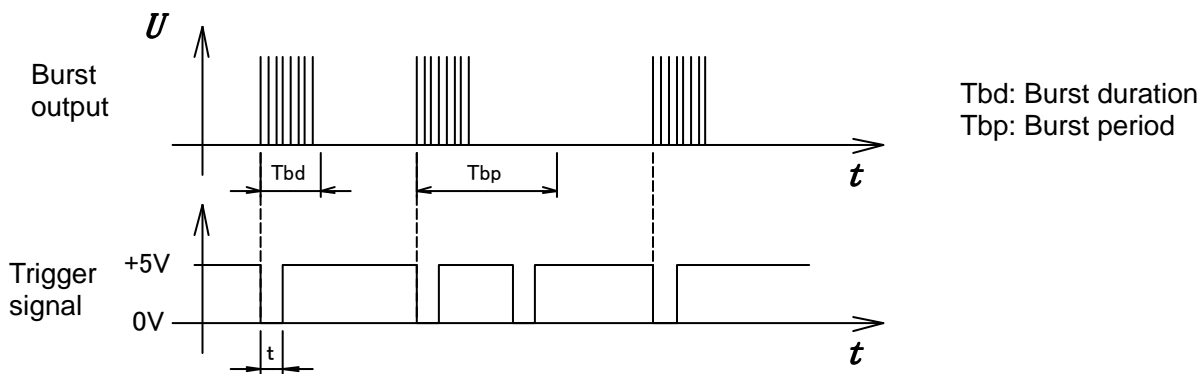
If input interval of trigger signals is shorter than burst period, the signal is ignored.



-  • The function cannot be used with the continuous output function. Turn OFF CONTINUOUS.
- If the external trigger and the phase angle synchronization are set up at the same time, the first output starts at the first specified phase angle.
- If there is no trigger for more than 90 second in conducting a test, the test will be stopped.





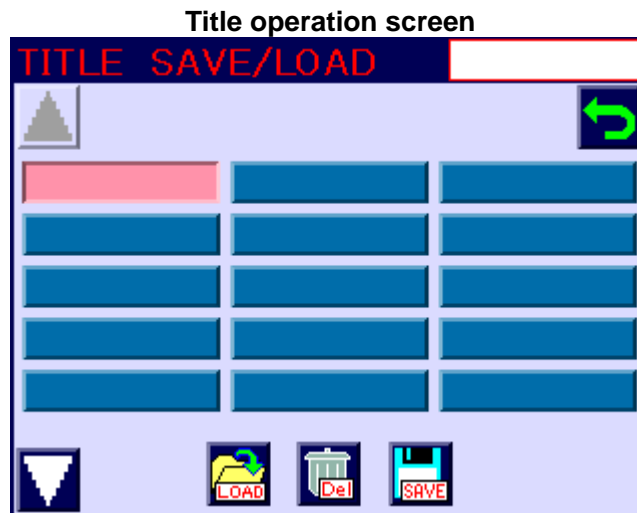

13-3. Title Save / Load

The set up test contents can be saved with naming a title. Saving 30 kinds of sets is available and each title can include 12 or less roman letters, digits. Select a title box and select 『LOAD/DEL/SAVE』.

☞ Touch , upper right on Manual test setting screen or Sweep setting screen, or touch 『LOAD』 on main menu.



List of icons for operation

Icon of key	Remarks
	Title box to save a title. There are 30 pieces (15 pieces x 2 pages) of title boxes.
	Used for turning the page.
	Used for loading the saved titled file.
	Used for deleting the saved titled file.
	Used for saving / saving after overwriting.
	Used for returning to Manual test setting screen and Sweep setting screen.



A test cannot start from this screen.

Save

Touch a title box for saving and touch  to indicate character key. Input a title and fix it with Enter.

Ex.) Save a new file as TEST 01.

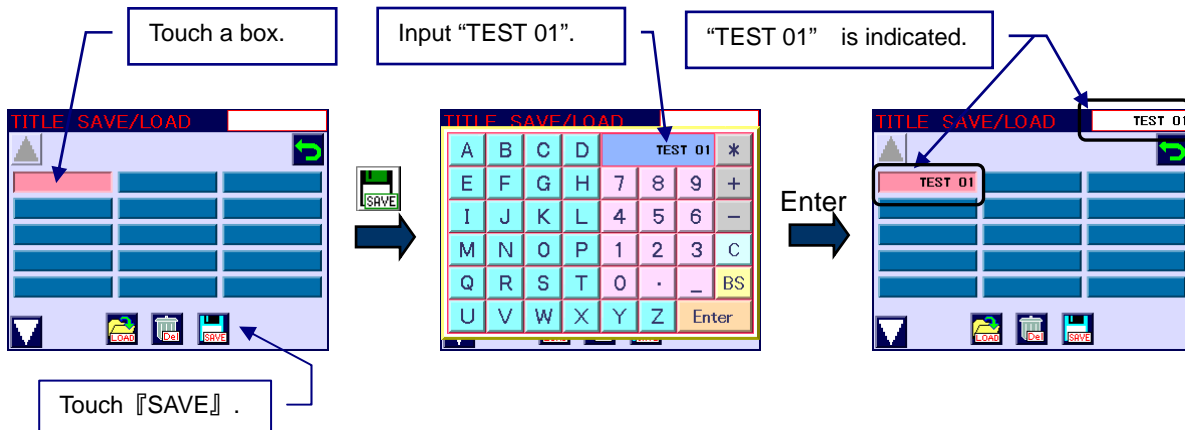

Overwriting

If you are trying to overwrite the already-saved file and save it, a check box appears. If 『OK』 is touched, the file is overwritten. In case overwriting is not necessary, touch 『CANCEL』 .

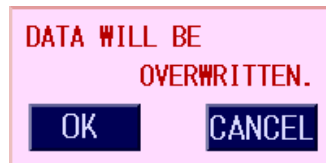

Changing title

The title of the saved file can be changed.

Touch a title box to be changed. → Touch the same box again to indicate character key. → Input a new title and fix it with Enter.



 If Enter is pressed without inputting any letter, the title is saved as 『NO NAME』 .

-  For details of character key, refer to P.35.
- Title operation (save / delete) can be prohibited. For details, Refer to "Prohibition of Title Operation" (P.71).

Load

Load means calling the saved titled file to use it for manual test set up.

 Touch the title box to be called.

 Touch  to call the saved test contents.



If there is another set up in editing on Manual test setting screen, a check box as below appears before start loading. In case loading is not necessary, touch 『CANCEL』 .



Check box to confirm LOAD

Delete

 Touch the title box to be deleted.

 Touch  and a check box as below appears. Touch 『OK』 to delete, 『CANCEL』 not to delete.



Check box to confirm DELETE



Title operation (save / delete) can be prohibited. For details, refer to "Prohibition of Title Operation" (P.71).

13-4. Executing Manual Test

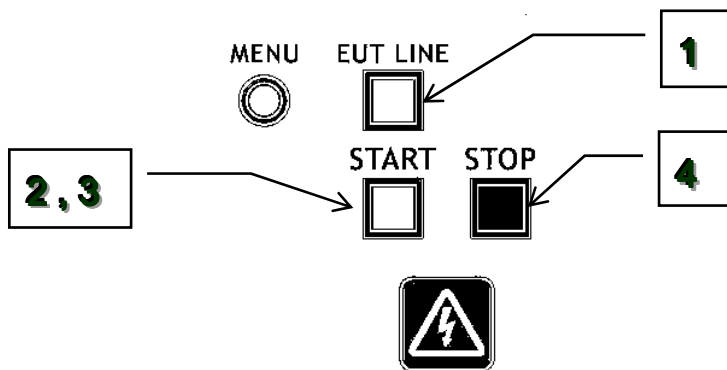

1. Power supply to EUT

In case of test to power line, press EUT LINE switch [EUT LINE] on control panel to connect the line. LED of EUT LINE switch is alight when power is supplied.



As power is supplied to line output terminal block [EUT LINE OUTPUT] when EUT LINE switch is turned ON, carefully handle the Unit and all related equipment.

2. Check screen

Press START switch to complete all conditions for test and to indicate the following check screen. Confirm the whole condition and press START switch again to start the test.

If **ESC** is touched on check screen, the screen will return to Manual test / Sweep setting screen.

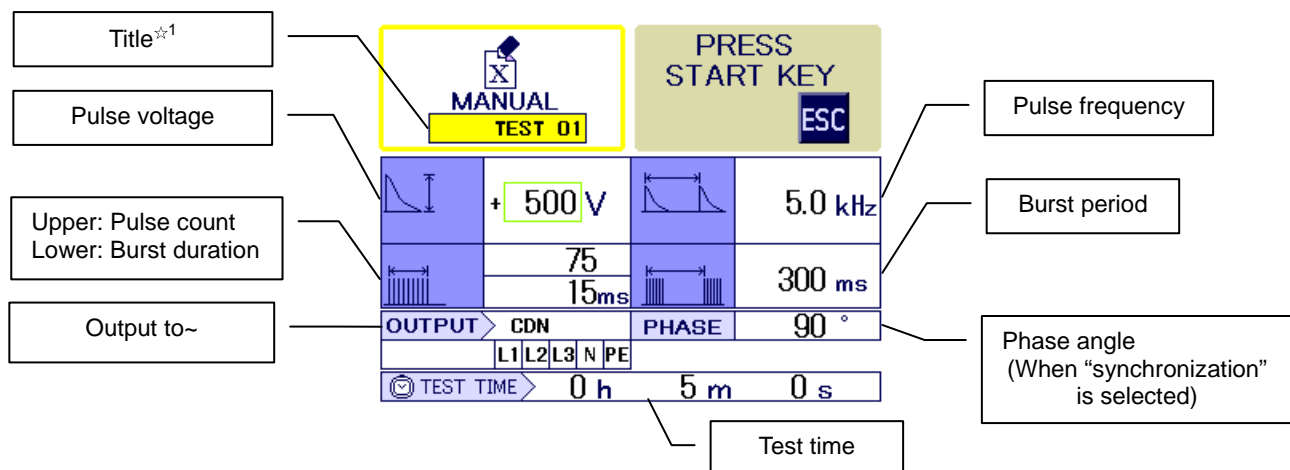

The indication of OUTPUT column depends on the selected test method. When POWER LINE is selected, 『CDN』 is indicated. When SIGNAL LINE is selected, 『PULSE OUT』 is indicated.

☆1 The title is indicated here when the test contents is saved.
If the test contents are edited after saving, the title is not indicated.

Check screen when “SWEEP” is set

The screenshot shows the manual test setup screen for 'TEST 02'. At the top left, there is a 'MANUAL' button with a pencil icon and 'TEST 02' below it. To the right, it says 'PRESS START KEY' with an 'ESC' key icon. The main display area is divided into several sections:

- Pulse voltage sweep:** Shows a pulse waveform icon, '+ 500 V', and a 'SWEEP' parameter of '500~2000 / 500'.
- Pulse frequency sweep:** Shows a pulse waveform icon, '5.0 kHz', and a 'SWEEP' parameter of '5.0~ 10.0 / 1.0'.
- CDN Coupling phase sweep:** Shows a pulse waveform icon, '75', '15ms', and an 'OUTPUT' dropdown set to 'CDN'.
- Phase angle sweep:** Shows a pulse waveform icon, '300 ms', and a 'PHASE' parameter of '0 °'.
- Phase angle sweep (When 『synchronization』 is selected):** Shows a 'SWEEP' parameter of '0~ 360 / 90'.
- TEST TIME:** Shows '0 h 5 m 0 s'.

 When SWEEP of pulse voltage, pulse frequency, or phase angle is set, start value, stop value, and step value are indicated in the bottom column. When CDN coupling phase sweep is set, 『LINE』 (in case of coupling to each phase) or 『ALL』 (in case of coupling to all combinations of phases) is indicated in the lower column.

3 Conducting test

『UNDER TEST』 is indicated upper right on the screen. While test is being conducted, START switch is alight and warning lump is blinking.



High voltage pulses are output. Mishandling or careless operation may result in a fatal wound. Carefully handle it.

The screenshot shows the manual test setup screen for 'TEST 01' during a test. At the top left, there is a 'MANUAL' button with a pencil icon and 'TEST 01' below it. To the right, there is a red warning box that says 'WARNING UNDER TEST HIGH VOLTAGE!'. The main display area is divided into several sections:

- Pulse voltage sweep:** Shows a pulse waveform icon, '+ 500 V', and a 'SWEEP' parameter of '500~2000 / 500'.
- Pulse frequency sweep:** Shows a pulse waveform icon, '5.0 kHz', and a 'SWEEP' parameter of '5.0~ 10.0 / 1.0'.
- CDN Coupling phase sweep:** Shows a pulse waveform icon, '75', '15ms', and an 'OUTPUT' dropdown set to 'CDN'.
- Phase angle sweep:** Shows a pulse waveform icon, '300 ms', and a 'PHASE' parameter of '0 °'.
- TEST TIME:** Shows '0 h 5 m 0 s'.

Pause

Pressing START switch while conducting test makes the output pausing. START switch is blinking and 『PAUSE』 is indicated upper right on the screen. For restarting the test, press START switch again.



If 『PAUSE』 status is left as is for 90 seconds, the test will be stopped automatically for safety.

Suspension

Pressing STOP switch while conducting test makes the test stop at the moment. START switch lights off and 『TEST suspended』 is indicated upper right on the screen.

☞ Confirming suspension, touch to return to Standard test setting screen.



Starting test again on this screen is not available. For restarting, touch to return to Standard test setting screen and start again on that screen. When test is complete, the Unit provides a lag for eliminating electricity of the internal circuit. Elimination needs about 4 seconds. For safety, restarting is not available during that period. When test is complete, LINE switch is not turned off automatically. Turn off the switch manually.

Changing pulse voltage

Pulse voltage can be changed while conducting and pausing test.

☞ Touch voltage column to indicate ten key. Input value and fix it with Enter.

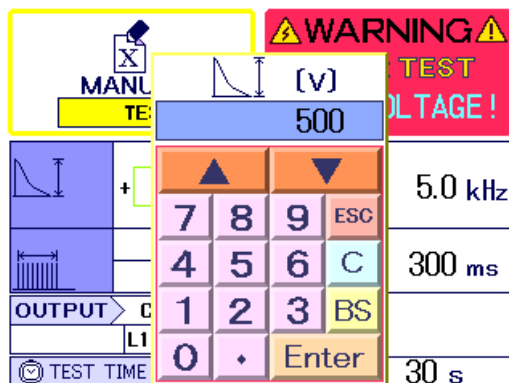

If Sweep function is effective in any parameter, pulse voltage cannot be changed. Even if pulse voltage is changed, when the screen returns to Manual test setting test after completing test, the value returns to the former value.

Moving to next test

In case of conducting a sequence test or a test set Sweep function, the following message is indicated when moving set up from one to another. While this message is indicated, electricity is eliminated in the internal high voltage circuit.

Now preparing
next test

When this stage finishes, the next test will start with the following procedure. If "AUTO" is selected for "SEQUENCE METHOD", the set up moves to the next one automatically, but if "MANUAL" is selected, the following message will appear. Press START switch to move to the next stage.

PRESS
START KEY



"SEQUENCE METHOD" can be selected on Utility (2) screen. For details, refer to "Sequence Method" (P.73).



While moving to next test, PAUSE function does not work.

5. Completion of test

Test is completed automatically when the set time has passed. START switch lights off and 『Test completed.』 Is indicated upper right on the screen.

Confirming completion, touch to return to Manual test or Sweep setting screen.

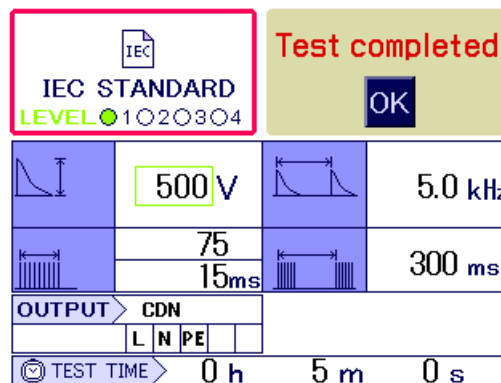

- Starting test again on this screen is not available. For restarting, touch to return to Manual test setting screen and start again on that screen. When test is complete, the Unit provides a lag for eliminating electricity of the internal circuit. Elimination needs about 4 seconds. For safety, restarting is not available during that period.
- In case of conducting test with LINE switch ON, when LINE switch is turned OFF, not only power supply is shut down, but also pulse generation is stopped.
- When test is suspended or completed, LINE switch is not turned off automatically. Turn off the switch manually.

14. SETTING UP SEQUENCE TEST

☞ Touch 『SEQUENCE』 on main menu.

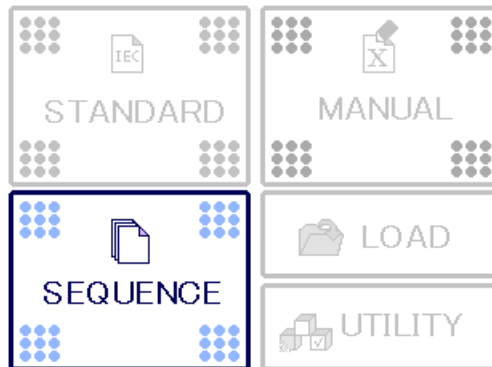

『SEQUENCE』 is the function to conduct test contents one after another which are saved on Manual test setting screen. Maximum 18 titles of settings can be formed into one sequence. The made up sequence can be saved as “sequence title”. The maximum 15 kinds of sequence titles can be saved (title: 12 or less Roman letters or digits).

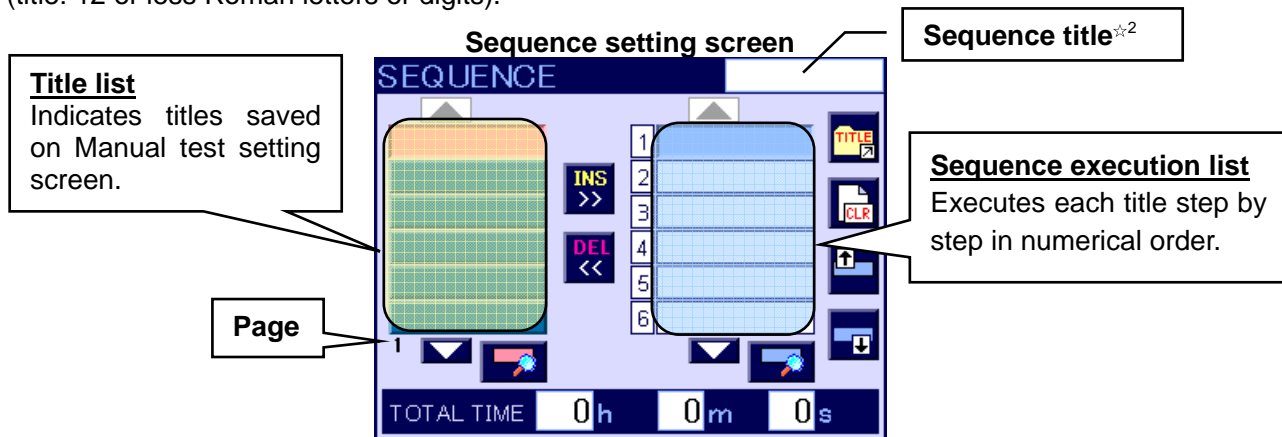









List of icons for operation

Icon of key	Remarks
	Used for inserting a title into the sequence execution list.
	Used for deleting a title from the sequence execution list.
	Short cut key to Sequence title operation screen. Used for saving a made-up sequence execution list. → Refer to P. 67.
	Used for deleting the whole of a sequence execution list which is being made up currently to make a new one from the beginning.
	Used for moving the selected title on the sequence execution list up by one column (↑), down by one column (↓).
	Used for scrolling the title list and the sequence execution list.
	Used for previewing the contents of the selected title on the title list or the sequence execution list. Touch the icon to indicate the screen.

☆2 The title is indicated here when the test contents is saved.

14-1. Making Sequence Execution List

1.  Touch one of the columns of the sequence execution list to select the column to be inserted into. (The sequence execution list has 3 pages. Touch   to scroll.)
2.  Touch one of the titles of the title list to select the title to add the sequence execution list. (The title list has 5 pages. Touch   to scroll.)
3.  Touch  to insert the selected title to the selected column of the sequence execution list. The selected column of the sequence execution list moves down by one column. After that, repeat procedure 2, 3. If the number of the titles listed on the sequence execution list exceeds 18, the following message appears.

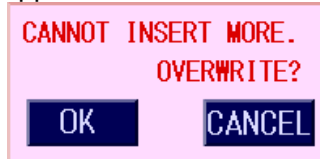

Example)

① Insert TEST 01.

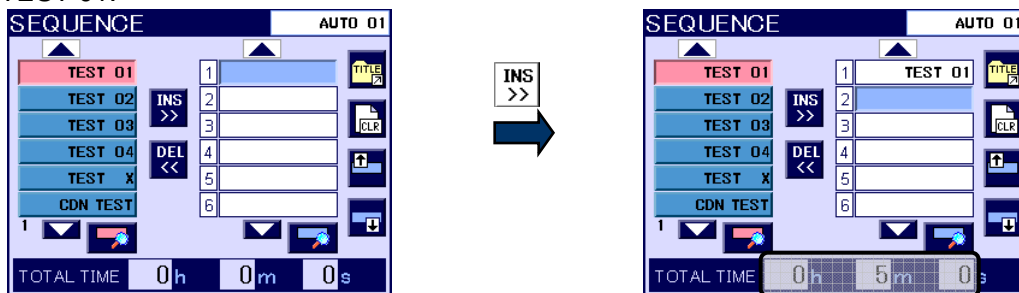

② Insert TEST 02.

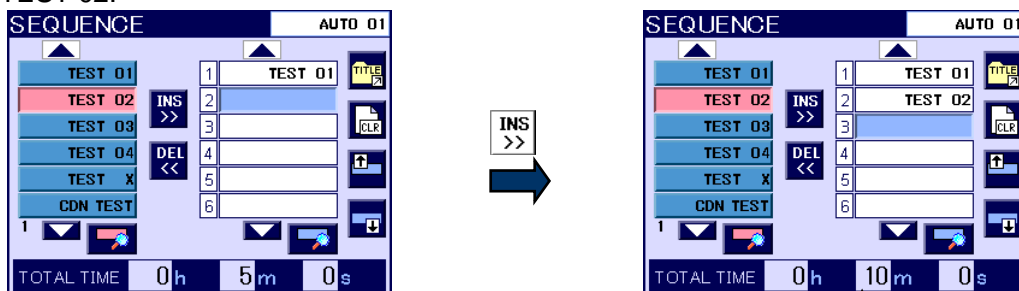



Total test time

The total test time of all titles of the sequence execution list is indicated.

Deleting a title from the sequence execution list

Touch the column to delete and touch .

Changing execution order

Touch the column to move up or down and touch  or .



Deleting the whole of an execution list

Touch . If there is any set up in the sequence execution list, a message appears.

Checking test settings



The test settings on the title list and the sequence execution list can be checked. Select the title to be checked and touch  of the title list side to indicate check screen. The set up saved on Manual test setting screen is indicated.

Similarly to the above, touch  of the execution list side to indicate check screen.

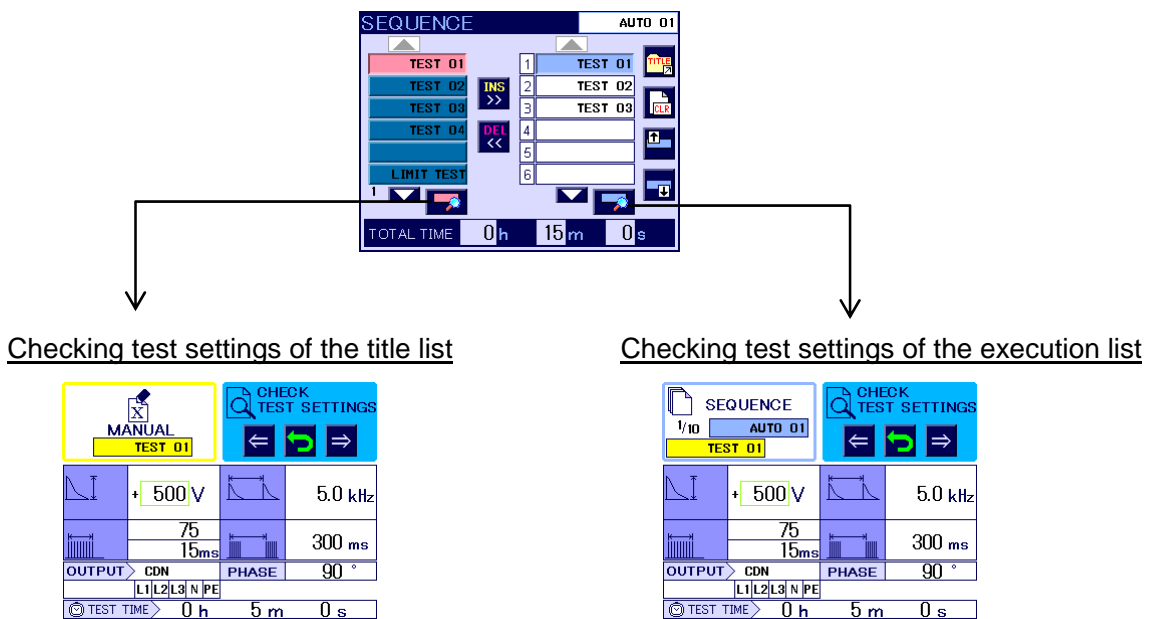
Touch  or  to indicate a set up of one page back or ahead. Touch  to return to Sequence setting screen.





List of icons for operation

Icon of key	Remarks
	Used for returning to Sequence setting screen.
 	Used for indicating the previous set up (←), or the next set up (→).

14-2. Saving Sequence Execution List



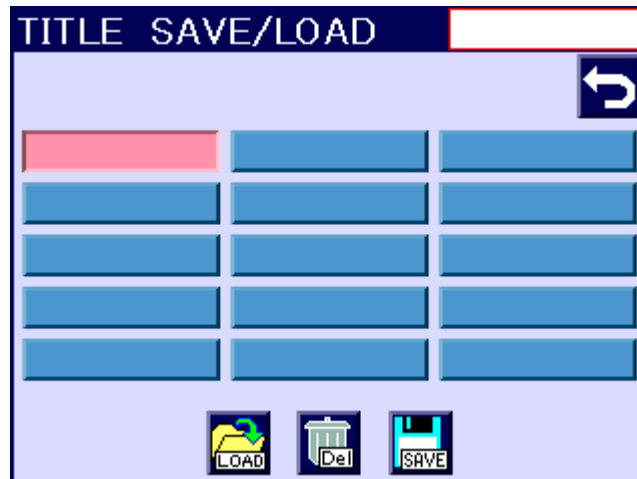

The set up sequence can be saved with naming a title. Saving 15 kinds of sequence is available and each title can include 12 or less roman letters, digits. Character key is indicated in inputting a title. For details of character key, refer to P.35.

Touch   upper right on Sequence setting screen to indicate Sequence title operation screen.

Sequence title operation screen



List of icons for operation

Icon of key	Remarks
	Sequence title box to save a sequence title. There are 15 pieces of sequence title boxes.
	Used for loading the saved sequence title.
	Used for deleting the saved sequence title.
	Used for saving / saving after overwriting.
	Used for returning to Sequence setting screen.



A test cannot start from this screen.

Save

☞ Touch the sequence title box to be saved and touch  to indicate Character key. Input a title and fix it with Enter.

Ex.) Save a new sequence title as AUTO 01.

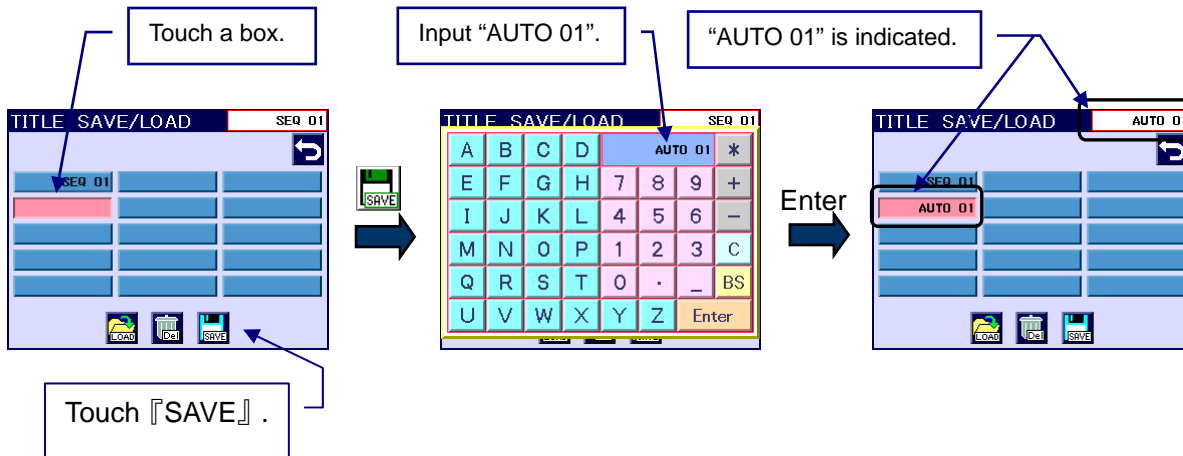

Overwriting

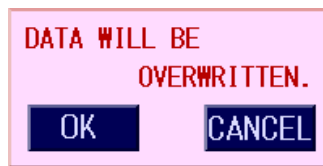

If you are trying to overwrite the already-saved box and save it, a check box appears. If 『OK』 is touched, the box is overwritten. In case overwriting is not necessary, touch 『CANCEL』 .



Changing title

The saved sequence title can be changed.



☞ Touch a title box to be changed. → Touch the same box again to indicate character key. → Input a new title and fix it with Enter.

-  If Enter is pressed without inputting any letter, the title is saved as 『NO NAME』 .
- 
 - For details of character key, refer to P.35.
 - Title operation (save / delete) can be prohibited. For details, refer to "Prohibition of Title Operation" (P.73).

Load

Load means calling the saved sequence title to use it for sequence test set up.

 Touch the title box to be called.

 Touch  to call the saved sequence title.



If there is another set up in editing on Sequence test setting screen, a check box as below appears before start loading. In case loading is not necessary, touch 『CANCEL』 .



Check box to confirm LOAD

Delete

 Touch the sequence title box to be deleted.

 Touch  and a check box as below appears. Touch 『OK』 to delete, 『CANCEL』 not to delete.



Check box to confirm DELETE



If the contents of one of the titles which form a sequence are changed, the contents of the sequence execution list which refers to the title will be changed also. If a title is deleted, the title is deleted from the sequence execution list also.



Title operation (save / delete) can be prohibited. For details, refer to "Prohibition of Title Operation" (P.73).

14-3. Executing Sequence Test

Sequence test can start on Sequence setting screen. If the sequence test execution list has any title, the start of the sequence test is available. Operation and matters requiring attention for testing are similar to Manual test. About execution of manual tests, refer to "13-4. Executing Manual Test (P.58).

Check screen

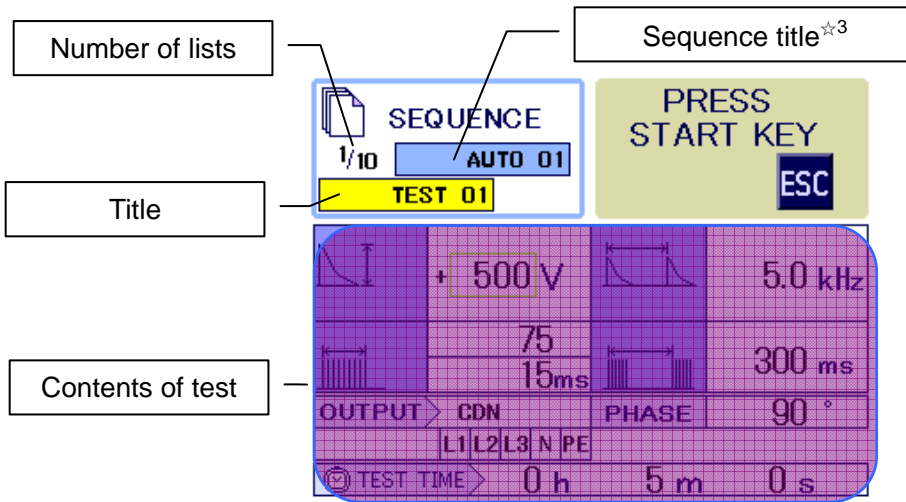

☆3 The title is indicated here when the test contents is saved.
If the test contents are edited after saving, the title is not indicated.

15. UTILITY

Touch 『UTILITY』 on main menu.

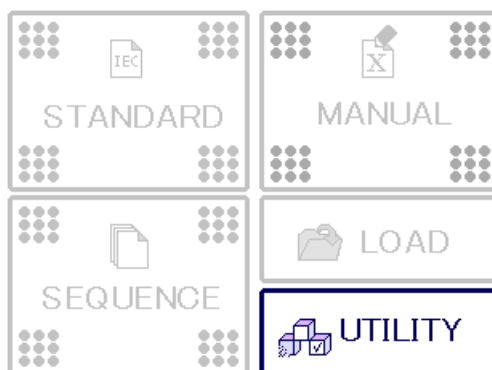

Some items which are not related with test parameters directly can be set as you like depending on situation on Utility screen. Utility screen has 3 screens (UTIL1, UTIL2, UTIL3). Touch an icon on the left on the screen to switch the screen.

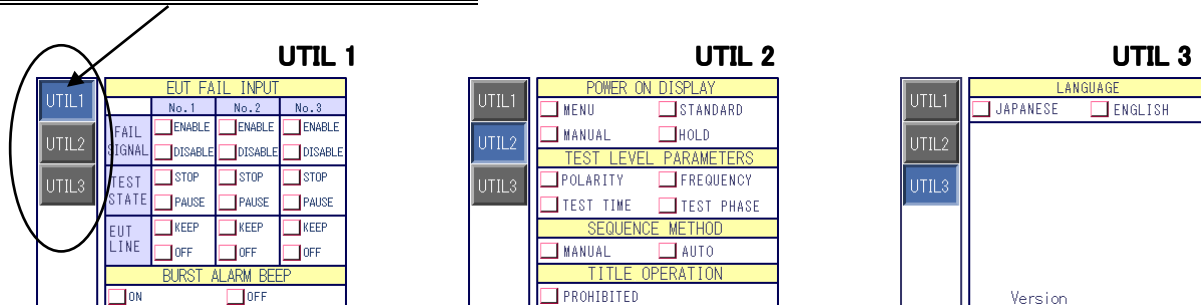

Setting EUT FAIL Signal

How to respond to a signal when EUT fails can be set. 1~3 channels of input can be set separately. As for how to connect EUT FAIL, refer to 16-1. 16-1. EUT FAIL P.74.

Touch 『UTIL 1』 → 『EUT FAIL INPUT』
Touch the check box (✓) depending on your need.

『FAIL SIGNAL』 : EUT FAIL signal input is effective if 『ENABLE』 is checked.

『TEST STATE』 : Selects how to respond to EUT FAIL signal.

Select 『STOP』 (to stop the test) or 『PAUSE』 (to pause the test) when 『ENABLE』 is checked for FAIL SIGNAL.

『EUT LINE』 : Selects line connection status when EUT FAIL signal is input.

Select 『KEEP』 (to keep line connection) or 『OFF』 (to shut down LINE) when CDN is used and 『ENABLE』 is checked for FAIL SIGNAL.

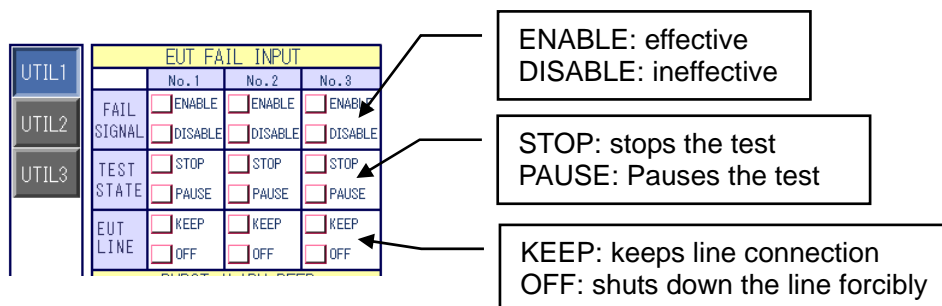

Burst Alarm BEEP

Selects whether an alarm sound beeps or not when test is conducted.

- Touch 『UTIL 1』 → 『BURST ALARM BEEP』
- Touch check box (☑)

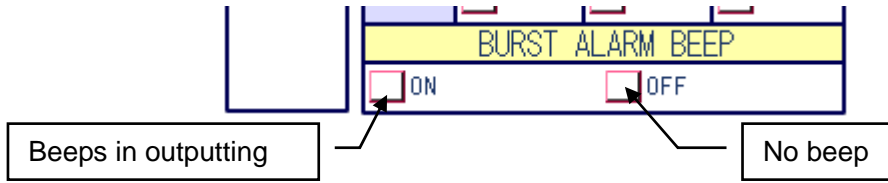

OFF is selected as a default value on shipment.

Power ON Display

Selects the first screen indicated when the Unit is turned ON.

- Touch 『UTIL 2』 → 『POWER ON DISPLAY』
- Touch the check box (☑) depending on your need.

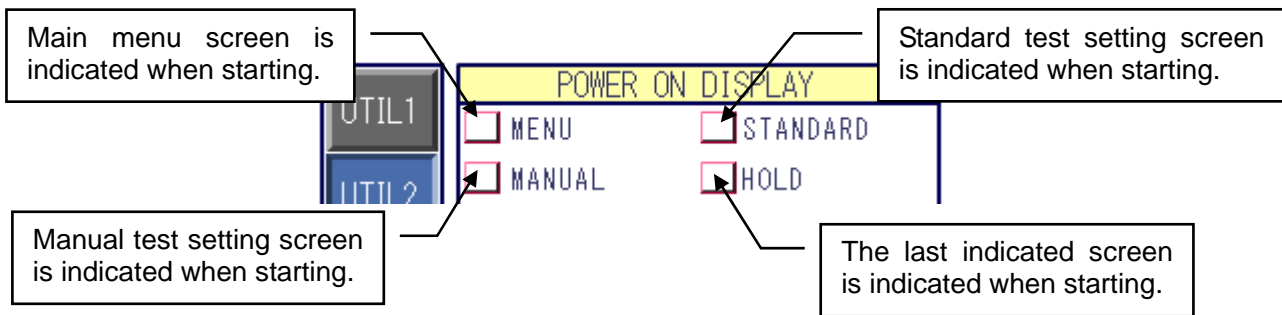

『HOLD』 is selected as a default value on shipment.

Setting up Common Items over Levels

Selects common parameters for all standard test levels 1~4.

- Touch 『UTIL 2』 → 『TEST LEVEL PARAMETERS』
- Touch the check box (☑) depending on your need.

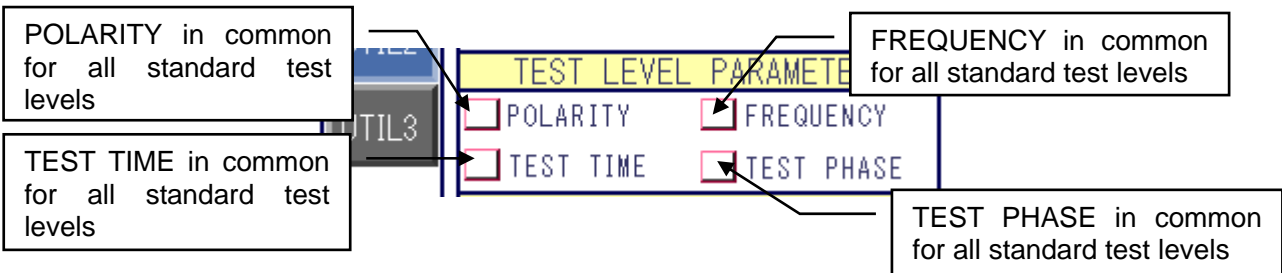

If an item is not checked, the item can be set for each level independently.

All items are checked (☑) as default values on shipment.

Sequence Method

Selects how to switch to the next stage when sequence test is selected.

- Touch 『UTIL 2』 → 『SEQUENCE METHOD』
Touch the check box (☑) depending on your need.



- ☐ 『MANUAL』 is selected as a default value on shipment.

Prohibition of Title Operation

On Title operation screen and Sequence title operation screen, operation of saving and deleting can be prohibited.

- Touch 『UTIL 2』 → 『TITLE OPERATION』
Touch the check box (☑) if prohibition is necessary.

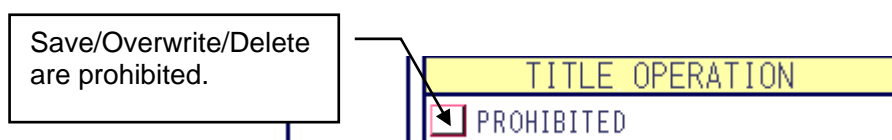

- ☐ OFF (not checked) is selected as a default value on shipment.

Language

Selects language (English or Japanese) on the screen.

- Touch 『UTIL 3』 → 『LANGUAGE』
Touch the check box (☑) depending on your need.



16. OTHER FUNCTIONS

16-1. EUT FAIL Function

With inputting a signal to EUT FAIL terminal, control, such as stopping or pausing, is available externally. The function can be utilized when EUT malfunctions.

The Unit does not have any function to judge EUT's malfunction. EUT FAIL signal should be prepared in user's side.

The connecting way and the signal input specifications are shown as under.

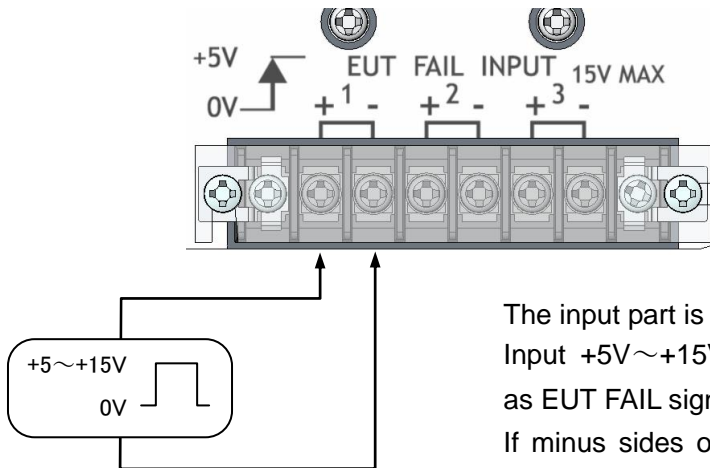

The input part is floated and 3 channels. Input +5V~+15V voltage between terminals as EUT FAIL signal. If minus sides of 3 channels are common, it does not matter.

The input interface of EUT FAIL is shown as a figure below.

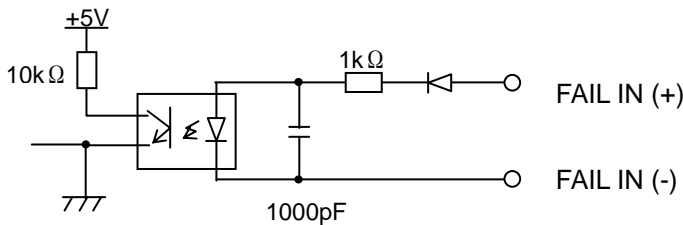

As for response of the Unit to EUT FAIL signal, refer to Setting EUT FAIL Signal (P.71).



All channels are 『DISABLE』 as a default value on shipment. Note that EUT FAIL signal is ineffective, as long as this set up is kept as is.

16-2. ALARM (Warning light)

The optional warning light can be connected to the Unit.

Connect the warning light to **【ALARM】** connector on the rear panel.

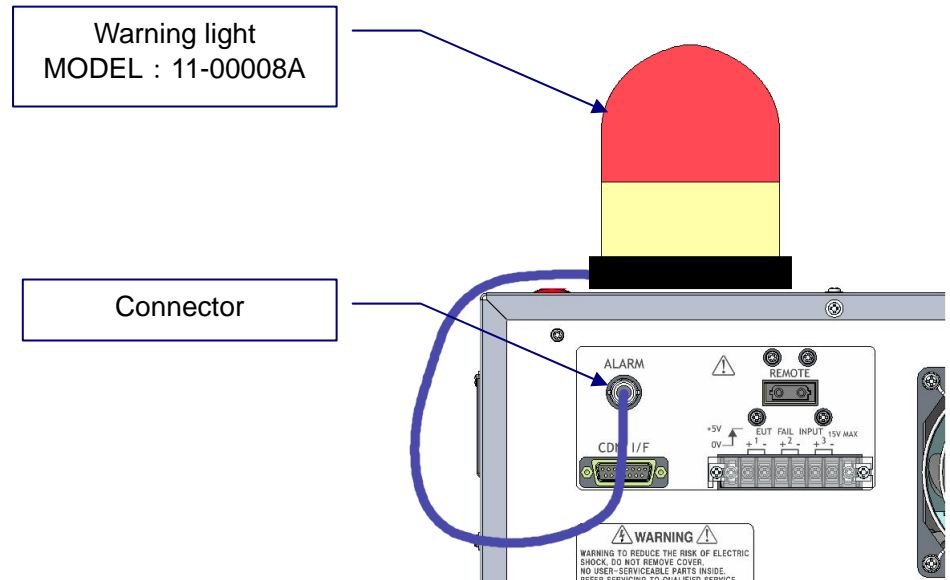

The warning light rotates and lights on as test is conducted.

The function of the warning light is same as the warning lamp on the control panel (→ Refer to P.23).

The warning light can call your attention in wider area.

※The warning light is equipped with a magnet for fixing, but it does not work for FNS-AX3 series.

16-3. Returning to Initial Setting

To return the whole setting to the initial setting in shipment, turn ON POWER switch **【POWER】** with pressing MENU switch **【MENU】**



When a user uses this function, all contents set on standard, manual, and sequence test screen and on utility screen are deleted simultaneously. This function is used only for returning the setting to the initial setting forcibly. Do not use it for usual turning ON/OFF.

17. ERROR MESSAGE

Errors indicated on the Unit are shown as below table.

Err No.	Indication	Meaning
ERROR1	EMERGENCY STOP CHECK SAFETY	Emergency stop button was pressed. The Unit cannot be operated. After confirming safety, turn on again. (For details, refer to P. 32)
ERROR2	SYSTEM EROOR	Repair is necessary. Ask Noise laboratory or its sales agent.
ERROR 4	LINE SYNC. ERROR	Test was about to start with setting line synchronization, but was not able to start because AC was not input.
ERROR 5	LINE SYNC. ERROR	Test with line synchronization was conducted, but the test was canceled because line cannot be detected.
ERROR 6	EUT FAIL SIGNAL RECEIVED	EUT FAIL signal was detected.
ERROR 7	FAN ERROR	Fan was stopped. Remove a substance blocking operation, if there is.
ERROR 8	TITLE IS PROTECTED	Save/Overwrite/Delete of title is prohibited.
ERROR 9	PULSE OUTPUT ERROR	Repair is necessary. Pulse output was not detected.

18. SPECIFICATIONS

18-1. Specifications of Generator

Item	Specifications
Output voltage	200V~4800V 10V step
Polarity	Positive and negative
Pulse Frequency	0.1kHz~2000kHz 0.1kHz ~ 1kHz /0.01kHz Step 1.0kHz ~ 10kHz /0.1kHz Step 10kHz ~ 100kHz /1kHz Step 100kHz ~ 1000kHz /10kHz Step 1000kHz ~ 2000kHz /100kHz Step Tolerance ±5% Tolerance ±10% (Available frequency is limited depending on pulse voltage.)
Pulse count	1~1000 1 step Limit: 1 pulse/ms per 1 burst (pulse frequency: More than 1kHz *1)
Burst duration	According to the formula as under. Pulse count / Pulse frequency Available range by direct input 0.01~999ms
Burst period	10~1000ms ±10% 10ms step (When alternate polarity is set, 500ms~)
Alternate polarity function	Burst is output to positive and negative polarity alternately. Conditions for setting: Burst period: Longer than 500ms, Burst resting period ([Burst period] – [Burst duration]): More than 100ms Maximum test time: 10 minutes
Continuous output	Outputs a continuous series of pulses. Set voltage ~1000V: Less than 10kHz ~2000V: Less than 4kHz ~4800V: Less than 1kHz Maximum test time: 10 minutes
Frequency modulation	Varies frequency continuously within the range between set frequency and approximately -10% of it. Modulation wave: Approximate 20Hz triangular wave.
External trigger	Outputs one burst with synchronized external trigger Trigger signal: Hi(+5V)→Lo(0V)

To be continued

***1 Example of setting: When burst period is 300ms, the range of pulse count is 1~300.**

Continued from previous page

Item	Specifications	
Waveform prescription (50Ω load)	Peak voltage: (Set value) /2±10% Rise time: 5ns±30% Pulse width: 50ns±30%	Prescribed with output waveform at 【PULSE OUT】 connector and with Set voltage: ±250V~4000V, Pulse frequency: 5kHz~100kHz
Waveform prescription (1kΩ load)	Peak voltage: (Set value)±20% Rise time: 5ns±30% Pulse width: 35~150ns	
D.C. blocking capacitor	10nF±20%	

18-2. Specifications of CDN

Item	Specifications
EUT Power capacity	A16C: Single-phase AC240V/16A, DC125V/16A (PE: 10A) B50C: 3-phase AC500V/50A, DC125V/50A (N/PE: 10A)
Coupling phase	A16C: L/N/PE B50C: L1/L2/L3/N/PE Each line, All lines, Combinations of lines
Coupling mode	Common mode
Output method	Output terminal block
Coupling capacitor	33nF
Waveform prescription (50Ω load)	Peak voltage: (Set value) /2±10% Rise time: 5.5ns (-1.5/+1.0) ns Pulse width: 45ns (-10/+15) ns Prescribed with Set voltage±4000V, Frequency 5kHz~100kHz
Input residual voltage	Less than 10% of set voltage Prescribed with EUT LINE input/output open
AC line synchronization	Synchronization, Asynchronization Phase angle: 0~360° ±10° 1° step Synchronization available range: AC85V~Rated voltage Based phase: Between L-N (A16C), Between L1-L2 (B50C) *2

***2 The set angle is to L (single-phase) or L1 (3-phase). For synchronization with other phases, calculate lag between the phase and L/L1 phase.**

18-3. Other Specifications

Item	Specifications
Emergency stop	Push-lock type switch (Stops testing, Turns EUT line OFF)
EUT FAIL function	Detects an external FAIL signal (Lo→Hi). FAIL signal $V_{Lo} : 0V, \quad V_{Hi} : +5V \sim +15V$ Operation after detection: Pause or Stop FAIL input: 3 channels
Accessories	AC cable SG cable Instruction manual
Operational environment	Temperature: 15~35°C Humidity: 25~75%
Dimensions	W320×H352×D400 (Without projection)
Weight	Approx. 14kg (A16C) Approx. 19kg (B50C)
Driving power supply	AC100~240V±10% 50/60Hz Approx. 120VA

18-4. Appearance

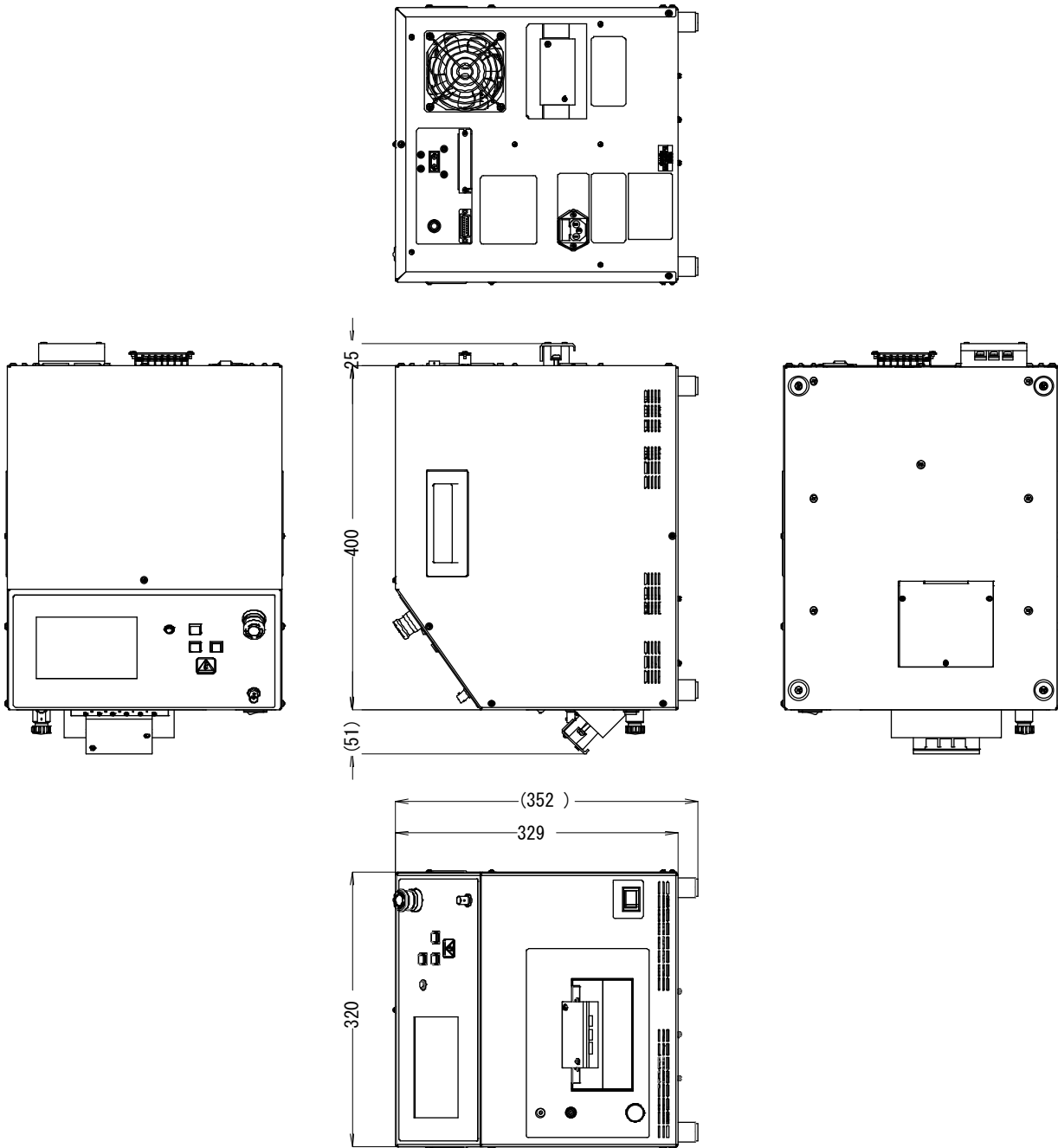

19. OPTIONAL PRODUCTS

Major optional products are as follows.

For details, enquire Noise Laboratory or your nearest sales agent of Noise Laboratory.

Items	MODEL No.	Remarks
Coupling clamp	15-00001A	Capacitive coupling clamp conforming to IEC61000-4-4.
Attenuator for waveform verification (50Ω)	AT-810	Attenuator to observe output waveform. Input impedance : 50Ω Output impedance : 50Ω Attenuation : 40dB (DC~500MHz)
Attenuator for waveform verification (1kΩ)	AT-811	Attenuator to observe output waveform. Input impedance : 1kΩ Output impedance : 50Ω Attenuation : 40dB (DC~500MHz)
CDN waveform verification connector	02-00131A	Connector for converting the output terminal block into a coaxial cable connector to observe waveform of CDN output
Outlet adaptor (Multiple outlet)	18-00077A	Adaptor for converting CDN output into various kinds of outlets
Warning light	11-00008A	Light rotating while testing for warning

20. WAVEFORM VERIFICATION

Preparation

- Oscilloscope (Frequency range: DC~500MHz or more)
- Attenuator AT-810: Optional product
(Input impedance: $50\ \Omega$, Output Impedance: $50\ \Omega$, Attenuation: 40dB)
- Attenuator AT-811: Optional product
(Input impedance: $50\ \Omega$, Output Impedance: $50\ \Omega$, Attenuation: 40dB)
- CDN waveform verification connector 02-00131A: Optional product

20-1. Verification at PULSE OUT

Waveform Verification with $50\ \Omega$ Load (In Case of Using AT-810)

- 1) Connect the input connector of AT-810 to PULSE OUT of the Unit with the attached coaxial cable (connector: NMHVP-NMHVP). Connect the output connector of AT-810 to the input of an oscilloscope. Insert an attenuator between them if necessary.
- 2) As the output impedance of AT-810 is $50\ \Omega$, terminate the input of oscilloscope with $50\ \Omega$.
- 3) Start the Unit.

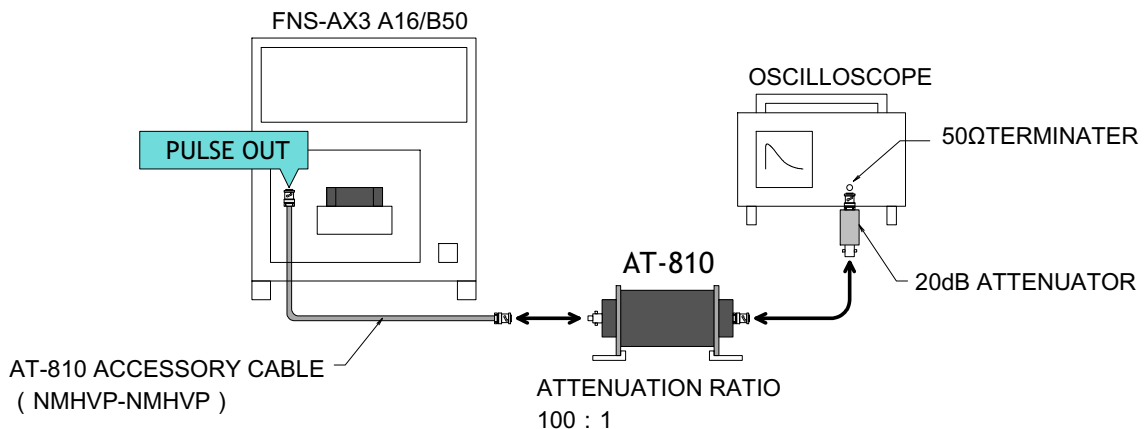

Waveform Verification with $1k\ \Omega$ Load (In Case of Using AT-811)

- 1) Connect the input side of AT-811 to PULSE OUT of the Unit directly. Connect the output side of AT-811 to an oscilloscope with the attached coaxial cable. Insert an attenuator between them if necessary.
- 2) As the output impedance of AT-811 is $50\ \Omega$, terminate the input of oscilloscope with $50\ \Omega$.
- 3) Start the Unit.

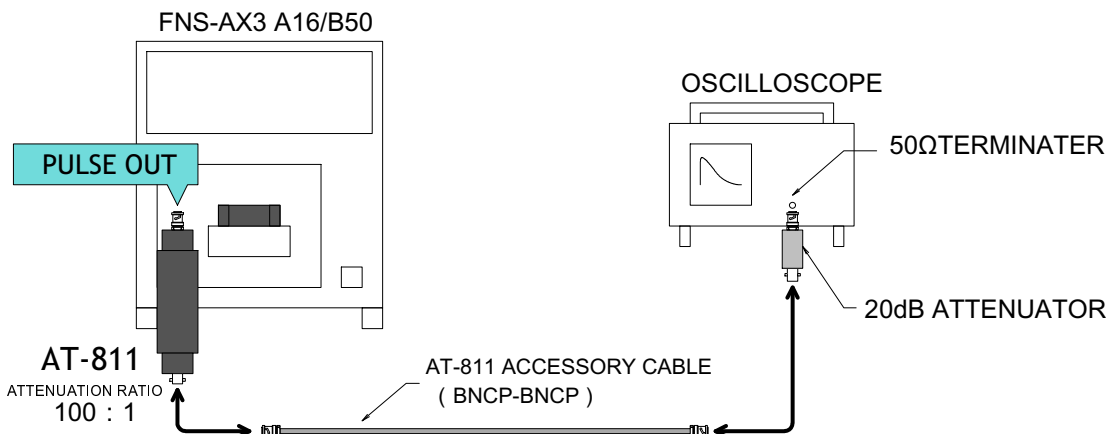



For observing waveform on an oscilloscope with connecting load resistance, the actual output voltage and the input restriction of the oscilloscope should be checked previously. The output voltage of the pulse to be observed can be found with applying the following [Formula 1] .

[Formula 1]

$$V_p = \frac{R_2}{Z + R_2} \times E$$

V_p : Output voltage of pulse to be observed
 R_2 : Load resistance
 Z : Output impedance
 E : Set voltage

In case of 50 Ω load

The output impedance of the Unit is approximately 50 Ω . If AT-810 (50 Ω load) is connected and the set voltage is 4000V, The output voltage of the pulse to be observed $V_{p(50\Omega)}$ is;

$$V_{p(50\Omega)} = \frac{50\Omega}{50\Omega + 50\Omega} \times 4000V \quad V_{p(50\Omega)} = 2000V^*$$

And as the attenuation ratio of AT-810 is 100:1, the result is; $2000V \div 100 = \mathbf{20V}$.

Check the input restriction of the oscilloscope and add a 50 Ω attenuator if necessary.

In connection on the left page, with using the 20dB attenuator, $20V \div 10 = 2V$.

In case of 1k Ω load

The output impedance of the Unit is approximately 50 Ω . If AT-810 (50 Ω load) is connected and the set voltage is 4000V, The output voltage of the pulse to be observed $V_{p(50\Omega)}$ is;

$$V_{p(1k\Omega)} = \frac{1k\Omega}{50\Omega + 1k\Omega} \times 4000V \quad V_{p(1k\Omega)} \doteq 4000V^*$$

And as the attenuation ratio of AT-810 is 100:1, the result is; $4000V \div 100 = \mathbf{40V}$.

Check the input restriction of the oscilloscope and add a 50 Ω attenuator if necessary.

In connection on the left page, with using the 20dB attenuator, $40V \div 10 = 4V$.

★The range of the pulse output voltage to be observed actually is as follows depending on specifications of the instrument.

$$V_{p(50\Omega)} = (\text{Set voltage}) / 2 \pm 10\%$$

$$V_{p(1k\Omega)} = (\text{Set voltage}) \pm 20\%$$

20-2. Verification at EUT LINE OUT

Waveform Verification with 50 Ω Load (In Case of Using 02-00131A and AT-810)

- 1) Remove the protection cover of the line output terminal block 【EUT LINE OUTPUT】 and unscrew the injection phase terminal to be measured.
- 2) Insert 02-00131A straightly into a datum earth socket located on upper part of the output terminal and fix the connector with the screw.

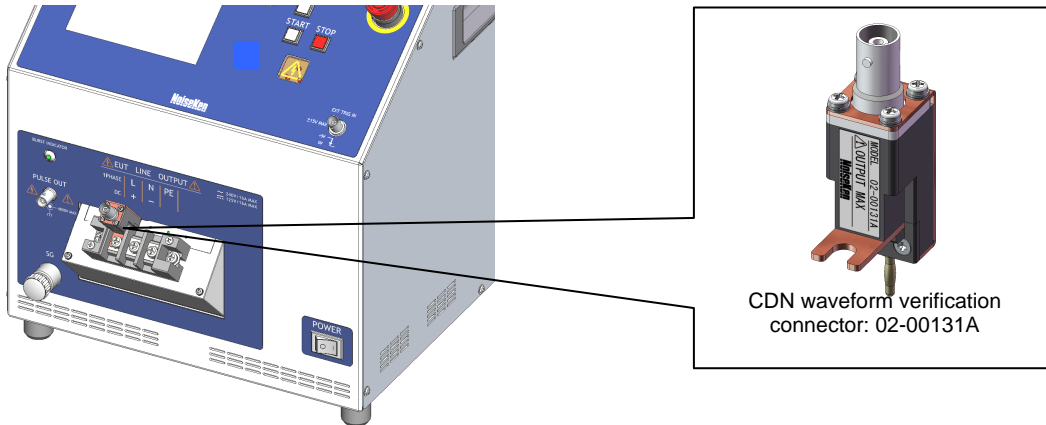

Before installing the connector, be sure to confirm that both EUT power supply and the Unit are turned OFF. The misuse may cause an electric shock.

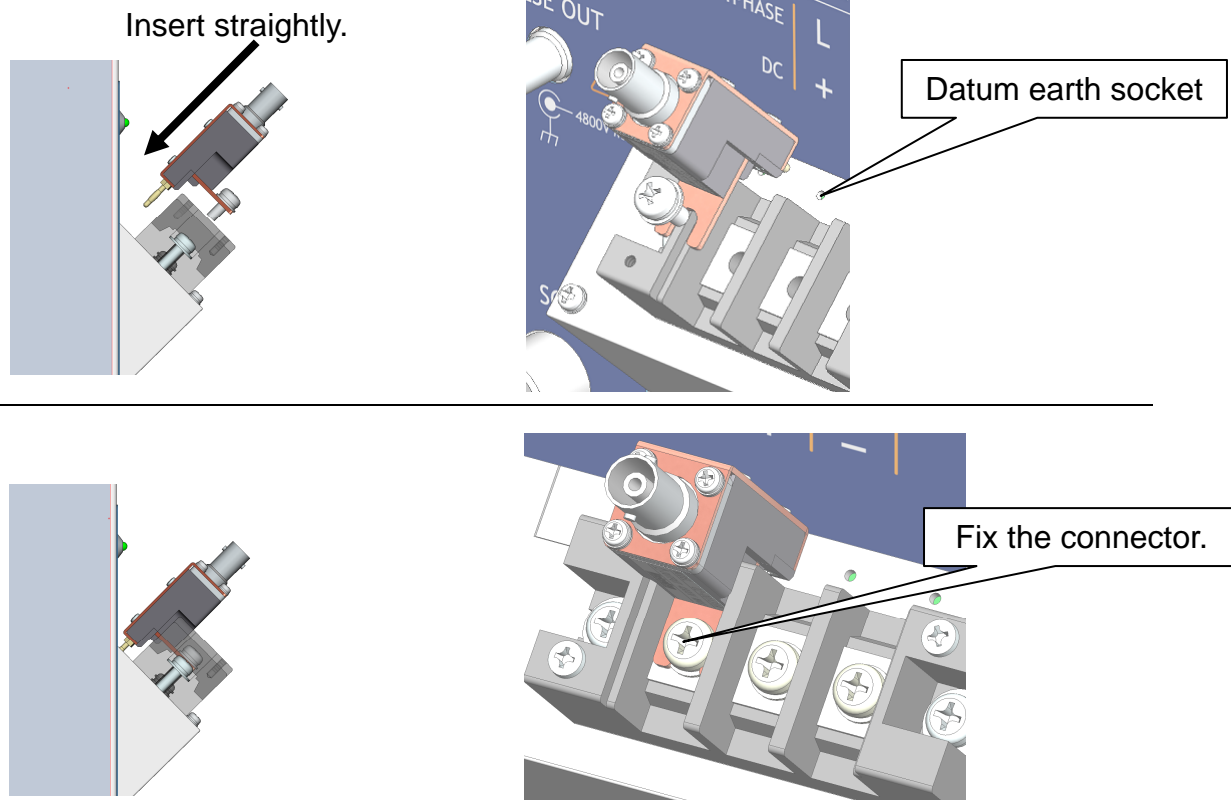

Fully be careful not to give mechanical stress to the Unit with installing the CDN waveform verification connector. The mechanical stress may cause damage or trouble.

- 3) Connect the CDN waveform verification connector 02-00131A to the input connector of AT-810 with a coaxial cable (connector: NMHVP-NMHVP) which is attached to AT-810 as the accessory. Connect the output side of AT-810 to an oscilloscope with the attached coaxial cable. Insert an attenuator between them if necessary.
- 4) As the output impedance of AT-810 is $50\ \Omega$, terminate the input of oscilloscope with $50\ \Omega$.
- 5) Start the Unit.

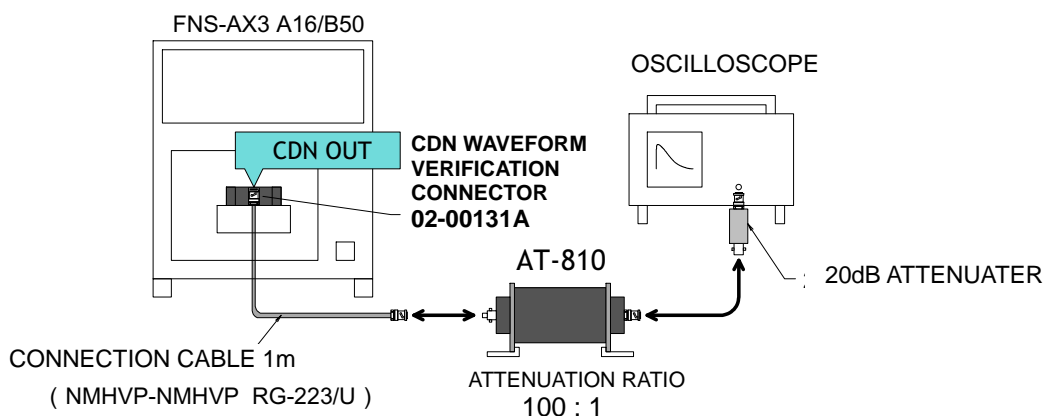



When verifying waveform, do not connect power supply to EUT LINE. (Turn OFF EUT LINE switch.) The misuse may cause damage or trouble of the attenuator and the oscilloscope. Since the protection cover cannot be installed, fully be careful about high voltage.



For observing waveform on an oscilloscope with connecting load resistance, the actual output voltage and the input restriction of the oscilloscope should be checked previously similarly to verification at PULSE OUT. Refer to  column in 20-1. Verification at PULSE OUT.



IEC standard has no prescription of output waveform with $1k\Omega$ load at CDN OUT.

20-3. Waveform for Reference

Set the input impedance of the oscilloscope 50Ω and make measurement range of the oscilloscope appropriate for the waveform to be measured.

Example of the observed waveform (Output: 1000V, Using AT-810)

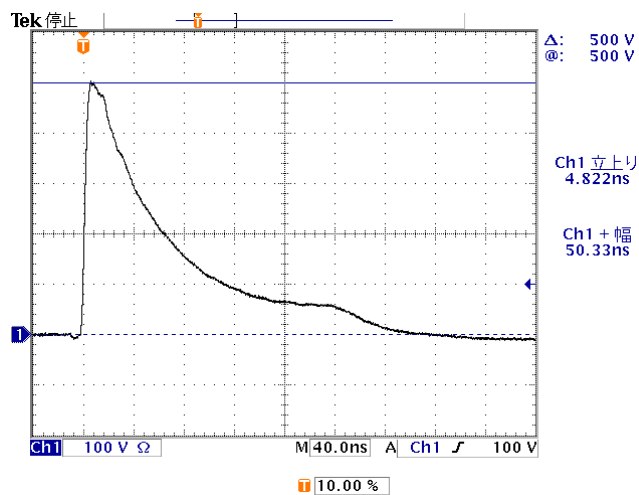

The measured value is half of the output value (500V in the above) because of 50Ω termination.

21. WARRANTY

Servicing terms

The following terms are applicable to servicing by Noise Laboratory Co., Ltd., (hereafter referred to as the Company) provided to maintain the intended performance of its products.

1. Scope

The following terms shall apply only to products made by the Company.

2. Technical servicing fee

In the event of a failure of a product within the warranty period (see warranty section), the Company will repair a product without charge. After the warranty expires, repairs will be billed at a nominal cost.

3. Ownership of defective parts

Any defective part exchanged under the Company's servicing belongs to it.

4. Limited liability

In the event that damages resulting from servicing by the Company are intentional or caused by negligence, the Company will pay the cost but at the purchase value of the relevant product maximum. But, notwithstanding the foregoing, the Company shall not be responsible for any incidental or consequential damages of any nature, including without limitation thereof loss of would-be profit or compensation demanded from a third party

5. Refusal to offer servicing

The company may not accept a repair order in the following cases:

- More than 5 years have passed since the product discontinued
- More than 8 years have passed after delivery
- Required component for servicing already discontinued and no alternative is available.
- Product changed, repaired or remodeled without obtaining a prior permission from the Company.
- Product severely damaged to the extent it has lost its original form

Limited warranty

Noise Laboratory Co., Ltd. (hereafter referred to as the Company) warrants its products to be free from defects in materials and workmanship under normal use and service for a period of one year from date of delivery. In the event of failure of a product covered by this warranty, the Company will repair the product or may, at its option, replace it in lieu of repair without charge.

Notwithstanding the foregoing, the Company shall not be responsible for any incidental or consequential damages of any nature, including without limitation thereof loss of would-be profit or compensation demanded from a third party. This warranty is valid only in Japan.

1. Scope

This warranty shall only apply to products made by the Company.

2. Period

One year from date of delivery. The warranty may be valid in 6 months after servicing if the same failure on the same component has repeated.

3. Exclusions

The followings are exclusions from this warranty:

- Consumable parts (including HV relay)
- Failure caused by misuse, neglect, accident or abnormal conditions of operation
- Failure caused by remodeling on the user side without prior permission from the Company
- Failure caused by servicing by unauthorized personnel by the Company
- Failure due to force majeure including but not limited to, acts of God, fire, war, riot, rebellion and others
- Failure due to shock or drop in or after transit
- Failure due to operation in environment being out of ambient specifications.
- A unit shipped to overseas.

22. MAINTENANCE

1. When repair, maintenance or internal adjustment of the unit is required, a qualified service engineer takes charge of such work.
2. Maintenance on the user side is restricted to the outside cleaning and functional check of the unit.
3. When checking or replacing the fuse, turn off the switch of the unit and disconnect the plug socket beforehand.
4. When cleaning the unit, turn off the switch of this unit and the connected equipment and disconnect the plug socket beforehand.
5. Avoid using chemicals for cleaning. Otherwise, the coating of the unit may peel off or the sight glass may be broken.
6. Do not open the cover of this unit.

23. NOISE LABORATORY SUPPORT NETWORK

- If a symptom which seems a trouble is found, inform the model name and serial number of the product together with the symptom to Noise Laboratory or your nearest sales agent of Noise Laboratory.
- When the product is returned to Noise Laboratory, write the state of the trouble, contents of your request, model name and serial number in a repair order, and pack the product and repair order sheet in the former package of equivalent suitable for transit and send them back.

NOISE LABORATORY CO., LTD.

SALES DEPT. TEL: +81-42-712-2051 FAX +81-42-712-2050

E-mail: sales@noiseken.com

<http://www.noiseken.com>

24. Information for CE Marking, EU and European territories

Manufacture: Noise Laboratory Co., Ltd
1-4-4, Chiyoda, Chuo-ku, Sagamihara City,
Kanagawa Pref., 252-0237, Japan

Importers: Territory: Germany, Austria, Benelux and Eastern Europe
DHS Elmea Tools GmbH Main Office
Carl-Zeiss-Strasse 43
63322 Roedermark, Germany

DHS Elmea Tools GmbH Office Tulln/Austria
Bruedergass 1-3, Top B14
3430 Tulln, Austria

DHS Elmea Tools GmbH Office BeNeLux
Het Voorburg 7
4101 KK Culemborg, Niederlande

Territory: Italy
TESEO SpA
Corso Alexander Fleming, 27
10040 Druento (TO), Italy

Territory: France, Spain and Portugal
AR France
Bat D1, 7 rue du fossé Blanc
92230 Gennevilliers, France

Territory: U.K., Ireland, Norway, Sweden and Denmark
AR Europe
Unit 8, Madingley Court, Chippenham Drive,
Kingston, Milton Keynes, Buckinghamshire MK10 0BZ, United Kingdom

Instruction for class A equipment:

Caution: This equipment is not intended for use residential environments and may not provide adequate protection to radio reception in such environments.

NOISE LABORATORY CO., LTD.

1-4-4, Chiyoda, Chuo-ku, Sagami-hara City, Kanagawa Pref., 252-0237, Japan

TEL: +81-42-712-2051 FAX: +81-42-712-2050

URL: <http://www.noiseken.co.jp>

Printed in Japan