

INSTRUCTION MANUAL

INJECTION UNIT

For LIGHTENING SURGE SIMULATOR

LSS-6000 SERIES

MODEL: LSS-INJ6400SIG

NOISE LABORATORY CO., LTD.

2.01Edition
AEE00146-00E-1B

NOTICE

The contents of this booklet are subject to change without prior notice.

No part of this booklet may be reproduced or transferred, in any form, for any purpose, without the permission of Noise Laboratory Co., Ltd.

The contents of this booklet have been thoroughly checked. However, if a doubtful point, an error in writing or a missing is found, please contact us.

Noise Laboratory Co., Ltd. shall have no liability for any trouble resulting from the misuse or improper handling of this product regardless of the contents of this booklet or arising from the repair or remodeling of this product by a third party other than Noise Laboratory Co., Ltd. or its authorized person.

Noise Laboratory Co., Ltd. shall have no liability for any trouble resulting from the remodeling or modification of this product.

In no event shall Noise Laboratory Co., Ltd. be liable for any results arising from the use of this produc

1. IMPORTANT SAFETY PRECAUTIONS

The following is very important matters in order to safely handle this product (called the unit hereafter). Read carefully and strictly observe them.

- 1. As the unit outputs high voltage (6600V maximum) and great current (157A maximum) by surge from LSS-6000 series, carefully handle it. Mishandling or careless operation may result in a fatal wound.**
- 2. Use of the unit and the lightning surge simulator (LSS-6000 series) unit in an explosive area such as "No fire" area etc. is prohibited. If used in such an area, it is liable to cause combustion or ignition due to discharge.**
- 3. Any person who has an implanted pacemaker in the body should not operate this unit. Furthermore, such a person should not enter the test area while this unit is operating.**
- 4. Test equipment to be used with this unit should be capable of insulating against at least a voltage of 6600V. The equipment under test (called EUT hereafter) using this unit should be performed in a protective enclosure or cover against scattering broken pieces, fire electric shock, etc.**
- 5. When connecting this unit to accessories for test waveforms and test conditions, optional equipment and other equipment, press STOP button of the lightning surge simulator (LSS-6000 series) and check that lamp of STOP button is lighting up beforehand. Otherwise, you may receive an electric shock. There may be residual voltage even if the test is stopped. Therefore, start operation after a lapse of more than 3 seconds.**

< LSS-6000 Series >

LSS-6010, LSS-6110: Combination Wave Generator

LSS-6030, LSS-6130: Combination Wave, 10/700 μ s Surge, 0.5 μ s/100kHz Ring Wave Generator

2. APPLICATION FORM FOR INSTRUCTION MANUAL

We place an order for an instruction manual.

Model: LSS-INJ-6400SIG

Serial No.: _____

Applicant:

Company name: _____

Address: _____

Department: _____

Person in charge: _____

Tel No.: _____

Fax No. _____

Cut off this page "APPLICATION FORM FOR INSTRUCTION MANUAL" from this volume and keep it for future use with care.

When an INSTRUCTION MANUAL is required, fill in the above Application Form and mail or fax it to the following sales department of our company.

To: Noise Laboratory Co., Ltd.
1-4-4 Chiyoda Chuo-ku Sagamihara City,
Kanagawa Pref., 252-0237 Japan
Tel: +81-(0)42-712-2051 Fax: +81-(0)42-712-2050

Cut
line

Memorandum

3. TABLE OF CONTENTS

1. IMPORTANT SAFETY PRECAUTIONS	1
2. APPLICATION FORM FOR INSTRUCTION MANUAL	3
3. TABLE OF CONTENTS	5
4. PREFACE	6
4-1 PREFACE.....	6
4-2 FUNCTIONS AND CAPABILITIES	6
5. BASIC SAFETY PRECAUTIONS	7
6. APPEARANCE OF THE UNIT	9
7. HOW TO CONNECT EQUIPMENT	11
7-1 CONNECTION OF REAR PANEL.....	11
7-2 CONNECTION OF FRONT PANEL (IN CASE OF LSS-6000 SERIES)	11
7-3 CONNECTION OF THE FRONT PANEL (IN CASE OF LSS-6230)	12
7-3 SETTING WHEN ARRESTORS COUPLING	13
7-4 SETTING WHEN CAPACITORS COUPLING	15
8. BLOCK CHART	17
9. SPECIFICATIONS	18
10. ACCESSORIES	19
11. WARRANTY	20
12. MAINTENANCE	22
13. NOISE LABORATORY SUPPORT NETWORK	23

4. PREFACE

4-1 PREFACE

We thank you for your purchase of the injection unit for the Lightning Surge Simulator LSS-6000 series: LSS-INJ6400SIG. This manual contains how to use the LSS-INJ6400SIG and other important information. In order to obtain the highest performance from your LSS-INJ6400SIG, thoroughly understand the contents of this manual and use as ready reference for operation.

The unit is the injection unit for tests for interconnection lines described in IEC61000-4-5.

Notice

- **The unit is just only for Lightning Surge Simulator (LSS-6000 Series).**
- **For details about how to use Lightning Surge Simulator (LSS-6000 Series), refer to the instruction manual of each model.**

4-2 Functions and capabilities

1. The unit is used for the surge immunity tests for interconnection lines described in IEC61000-4-5.
2. EUT's power capacity is DC50V/1A. The unit can be used to inject high voltage surge (maximum 6600V) to interconnection lines.
3. Bypassing 20mH inductor is available by connecting the connection plug in the accessory to the inductor bypass terminal.
4. The protective arrester in the accessory is attachable between each line and ground.

5. BASIC SAFETY PRECAUTIONS

1. As the unit outputs high voltage (6600V maximum) and great current (157A maximum) by surge from LSS-6000 series, carefully handle it. Mishandling or careless operation may result in a fatal wound. Do not touch the surge in connector, DC line out connector, DC line in terminal in conducting tests because high voltage is generated.
2. Use of the unit and the lightning surge simulator (LSS-6000 series) unit in an explosive area such as "No fire" area etc is prohibited. If used in such an area, it is liable to cause combustion or ignition due to discharge.
3. Any person who has an implanted pacemaker in the body should not operate this unit. Furthermore, such a person should not enter the test area while this unit is operating. Otherwise, the electronic medical device can malfunction so that can result fatal.
4. Mishandling or careless operation may result in fatal wounds.
5. Test equipment to be used with this unit should be capable of insulating against at least a voltage of 6600V. The equipment under test (called EUT hereafter) using this unit should be performed in a protective enclosure or cover against scattering broken pieces, fire electric shock, etc.
6. Do not touch surge in cables, line out cables etc. Otherwise, a fatal accident may happen.
7. In case of touching the surge in connector, the socket of DC line out (the hole for inserting the connection plug), and DC line in terminals just after conducting tests, as it takes about 3 seconds for automatic elimination of electricity of the lightning surge simulator, do not touch them for this interval.
8. Never fail to connect PE terminal to the FG terminal of the lightning surge simulator by PE cable (accessory).
9. EUT can be electrified by high voltage after injecting surge. Eliminate electricity of EUT before touching it.
10. In case of touching DC line out connector, never fail to make high voltage circuit "OFF" status by pressing STOP button or EMERGENCY button.

- 11. Connect the connection plug, the capacitor / arrestor unit, the arrestor unit, and the surge protection arrestor correctly and firmly depending on the test application. Misconnection may cause very dangerous situation because of residual high voltage.**
- 12. Never fail to watch the unit, the lightning surge simulator, and EUT in operation.**
- 13. Do not open the unit because high voltage is generated internally.**
- 14. In case of bypassing the inductor of each line's decoupling network, as the surge can be back to the input side with some EUT impedance condition, connecting protection instruments is recommendable. The surge protection arrestor in the accessory can connect between each line and ground. The discharge starting voltage of the arrestor is approximately 350V under 1kV/ μ s condition. Even if the arrestor is connected, the voltage less than the discharge starting voltage may return to line input side and damage the power supply. In such a case, connect a protective instrument between the power supply and line in.**
- 15. Avoid using or storing the unit in high or low temperature environment. (Operating temperature range: 15-35°C / Operating humidity range: 25-75%)**
- 16. If dewing or condensation occurs, thoroughly dry it before operating the unit.**
- 17. Avoid using the unit in an extremely humid or dusty place.**
- 18. Our company and sales agents shall have no responsibility for any accident resulting in injury or death, any breakage or resultant damages due to irresponsible handling.**
- 19. Only a qualified engineer can perform repair, maintenance and internal adjustment of the unit.**
- 20. Use the accessories and optional equipment supplied by our company for safe handling.**
- 21. Avoid giving a strong shock to the unit.**
- 22. Do not wipe the unit with thinner, alcohol or similar solvent. When the body is dirty, soak a cloth in detergent, squeeze the cloth and wipe the body with it.**

6. APPEARANCE OF THE UNIT

FRONT PANEL

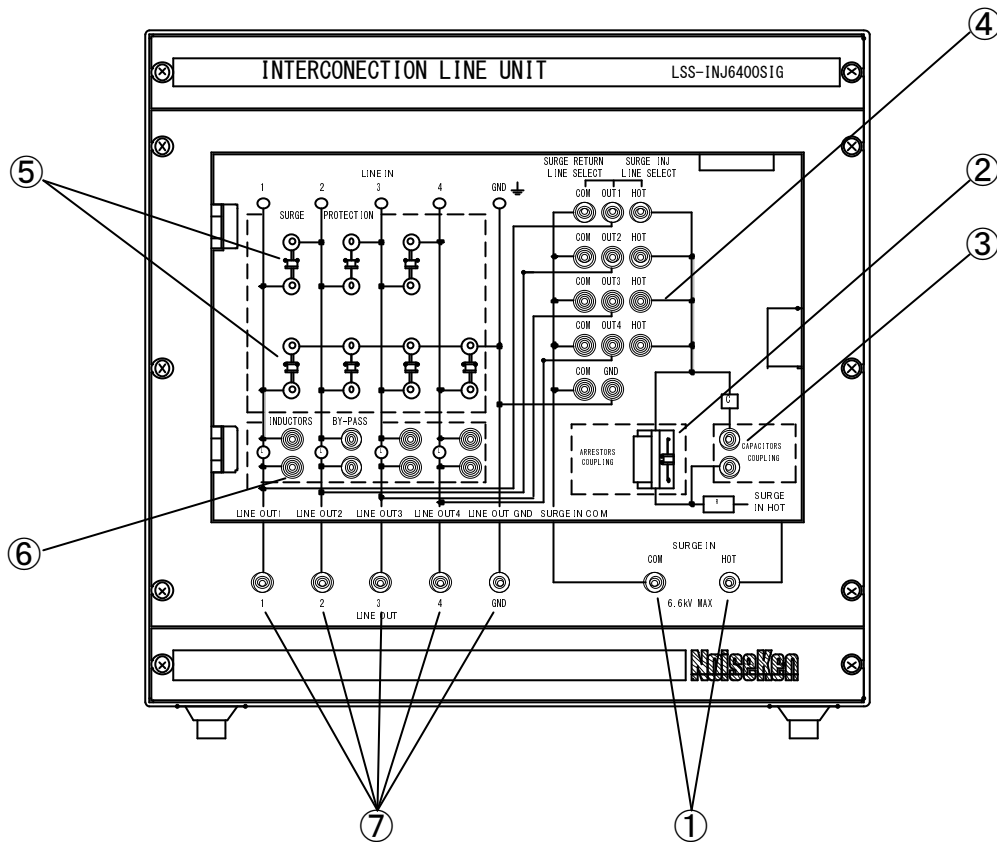

- ① **SURGE IN CONNECTOR [SURGE IN: HOT, COM]:** Used for inputting surge from the lightning surge simulator. Connect [HOT] to [L1] of LSS-6000 series and [COM] to [L2] by the surge connecting cable.
When using LSS-6230, the HOT and COM sides shall be connected to the L and N
- ② **sides of EUT LINE OUTPUT terminals, respectively, by using the supplied**
- ③ **Surge IN Cable (for LSS-6230)**
- ④ **ARRESTORS COUPLING PART [ARRESTORS COUPLING]:** Connects the capacitor / arrestor unit or the arrestor unit (accessory) in case of arrestor coupling test.
- ⑤ **CAPACITORS COUPLING PART [CAPACITORS COUPLING]:** Connects the connection plug (accessory) in case of capacitor coupling test.
- ⑥ **SURGE INJECTION SETTING PART [SURGE INJ LINE SELECT] [SURGE RETURN LINE SELECT]:** Selects surge injection line and return line.
- ⑦ **SURGE PROTECTION INSTRUMENT CONNECTOR [SURGE PROTECTION]:** Used for connecting surge protection instruments to avoid surge return. A gas arrestor (90V) is connected when shipped. Remove the gas arrestor or connect other surge protection instruments depending on cases.
- ⑧ **INDUCTOR BY-PASS CONNECTOR [INDUCTORS BY-PASS]:** Connects the connection plug in case of bypassing inductors in the decoupling network. In case of bypassing inductors, never fail to bypass all lines.
- ⑨ **DC LINE OUT CONNECTOR [LINE OUT: 1,2,3,4,GND]:** Supplies power to EUT and injects surge to lines set by surge injection set part.

REAR PANEL

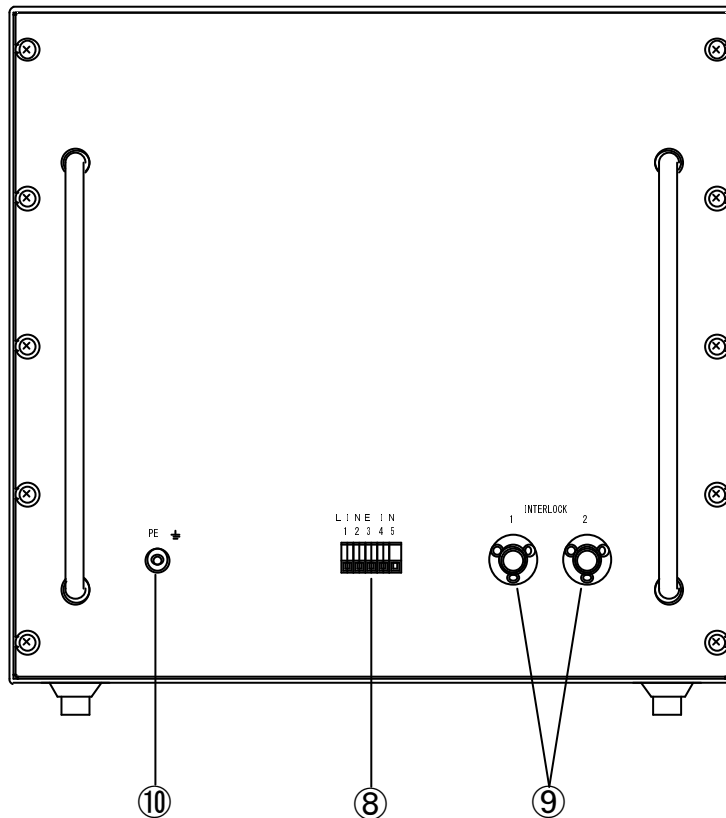

⑧ **DC LINE IN TERMINAL [LINE IN]:** Inputs power for EUT.

⑨ **INTERLOCK CONNECTOR [INTERLOCK: 1,2]:** Connect [1] to the lightning surge simulator's interlock connector by the interlock connection cable (accessory). Connect interlock connector (of the surge simulator's accessory) to [2].

⑩ **PE TERMINAL [PE]:** Protective Earth terminal of the unit. Never fail to connect [PE] to FG terminal of the lightning surge simulator (LSS-6000 series) by PE cable (accessory).

7. HOW TO CONNECT EQUIPMENT

7-1 Connection of Rear Panel

Connect PE terminal to FG terminal of LSS-6000 series by PE cable (accessory) as indicating in the figure below. Connect the interlock connector [1] to the LSS-6000 series interlock connector by the interlock cable (accessory). As not attached, prepare cable to Line In terminal (material: AGW10-24).

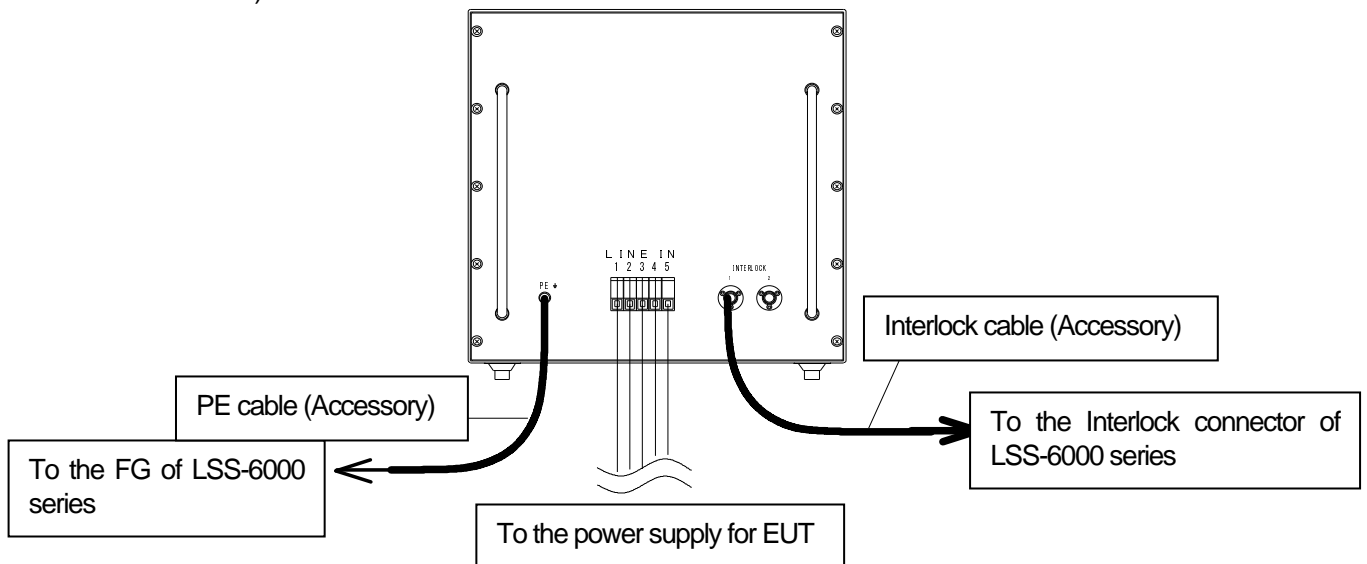

7-2 Connection of Front Panel (in case of LSS-6000 Series)

Connect the surge in connector [SURGE IN: HOT, COM] to the surge out terminal [L1, L2] by the surge in cable (accessory). Connect line out connector [LINE OUT: 1,2,3,4,GND] to EUT by DC line cable.

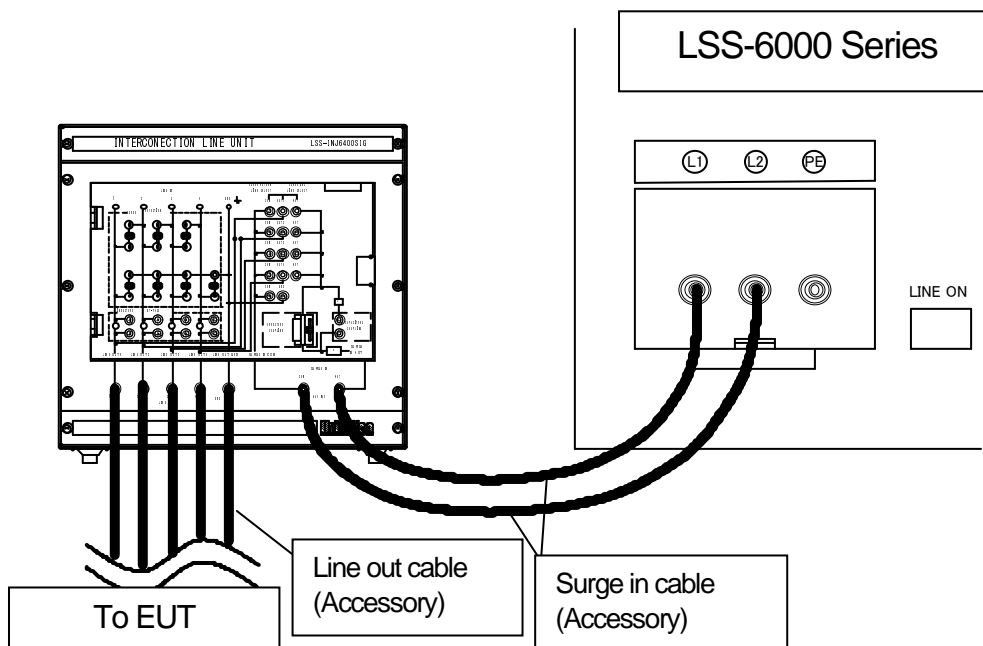

7-3 Connection of the front panel (in case of LSS-6230)

Connection of the LSS-INJ6400SIG to the LSS-6230 is done by using the supplied Surge In Cable. Connect the safety socket side of the cables to the SURGE IN terminals on the LSS-INJ6400SIG and solderless terminal side to the EUT LINE OUTPUT (L, N) terminals on the LSS-6230.

Next, connect the safety socket side of the supplied Line Out Cables to the LINE OUT terminals (LINE OUT1, 2, 3, 4, GND). Connect the EUT to the other end of the cables (clip side)

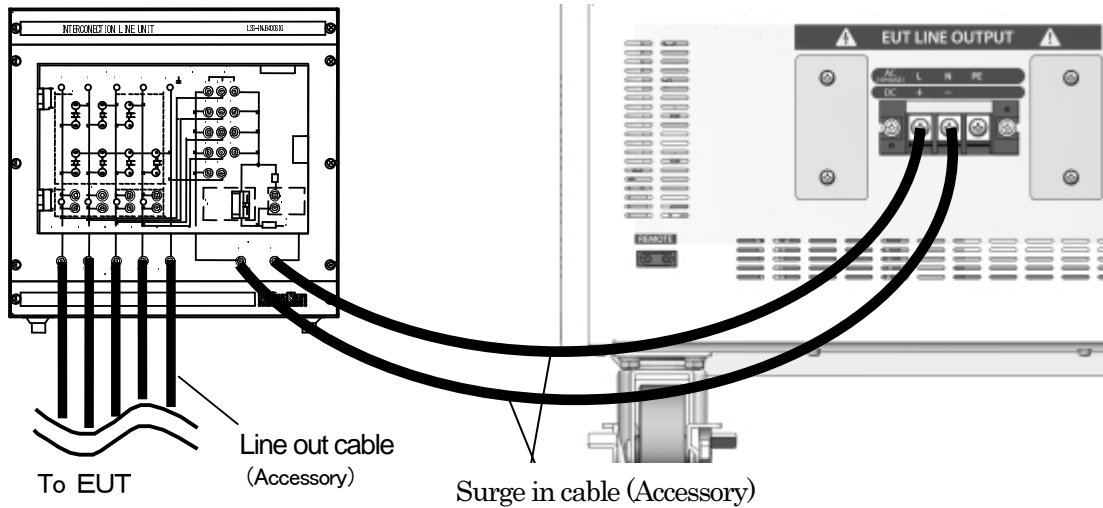

7-3 Setting When Arrestors Coupling

(1) To inject surge to Line - Line

Example: In case of injection line: [OUT1] and return line: [OUT2]

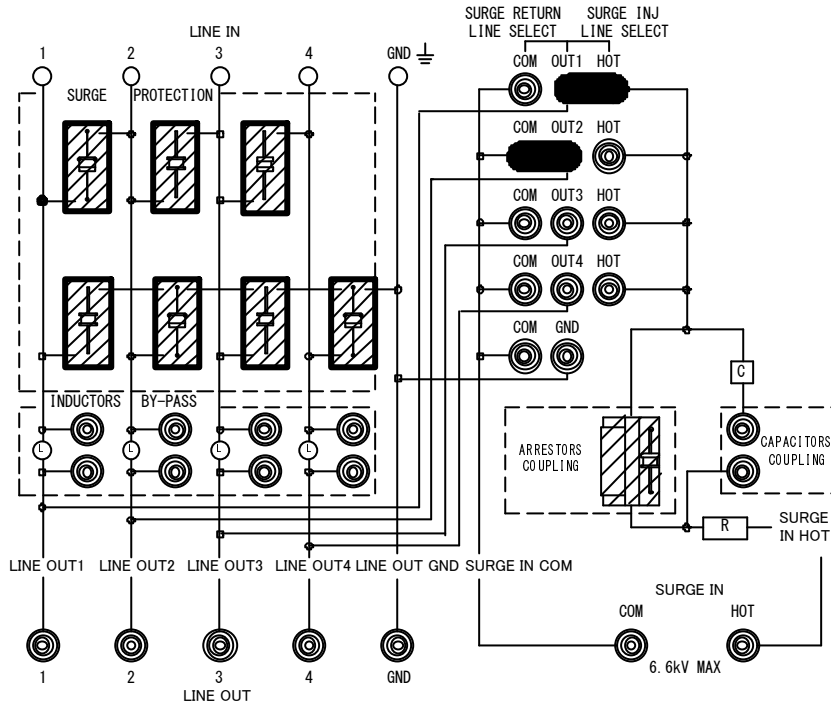

- ① Connect the capacitor / arresstor unit (accessory) or the arresstor unit (accessory) to [ARRESTORS COUPLING].
*Use the capacitor / arresstor unit if transmission signal of EUT is less than 5kHz, and use the arresstor unit if more than 5kHz.
- ② Connect the connection plug to [SURGE INJ LINE SELECT] [SURGE RETURN LINE SELECT]. The above figure shows the example of setting [OUT1] as the surge injection line and [OUT2] as the surge return line.
- ③ The gas arresstor (90V) is connected to [SURGE PROTECTION]. Remove the gas arresstor or connecting another surge protection instrument depending on necessity.
*The gas arresstor is connected when shipped. The gas arresstor should be changed if it does not emit light when surge injected. In case of using surge absorbers etc other than the gas arresstor, connect a surge protection instrument depending on test conditions.
- ④ In case of bypassing the inductor (20mH) in the decoupling network, connect the connection plug (accessory) to [INDUTORS BY-PASS]. Never fail to bypass all lines.
*In case of bypassing the inductor (20mH), the surge may return to the line input side and damage EUT. Besides, the surge may not inject to EUT.

(2) To inject surge to Line-Ground

Example: In case of injection line: [OUT1] and return line: [GND].

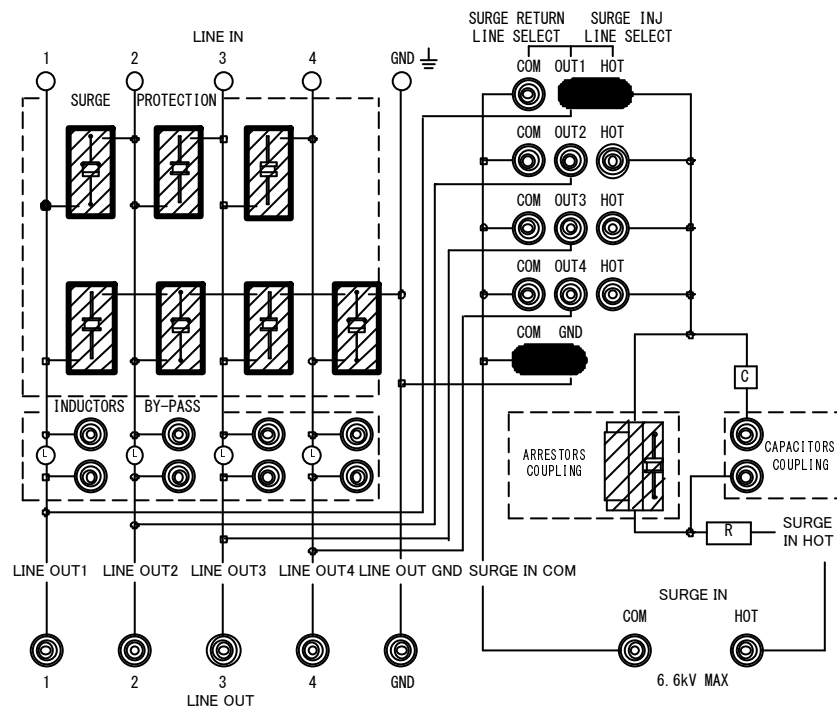

- ① Connect the capacitor / arrester unit (accessory) or the arrester unit (accessory) to [ARRESTORS COUPLING].
*Use the capacitor / arrester unit if transmission signal of EUT is less than 5kHz, and use the arrester unit if more than 5kHz.
- ② Connect the connection plug to [SURGE INJ LINE SELECT] [SURGE RETURN LINE SELECT]. The above figure shows the example of setting [OUT1] as the surge injection line and [GND] as the surge return line.
- ③ The gas arrester (90V) is connected to [SURGE PROTECTION]. Remove the gas arrester or connecting another surge protection instrument depending on necessity.
*The gas arrester is connected when shipped. The gas arrester should be changed if it does not emit light when surge injected. In case of using surge absorbers etc other than the gas arrester, connect a surge protection instrument depending on test conditions.
- ④ In case of bypassing the inductor (20mH) in the decoupling network, connect the connection plug (accessory) to [INDUTORS BY-PASS]. Never fail to bypass all lines.
*In case of bypassing the inductor (20mH), the surge may return to the line input side and damage EUT. Besides, the surge may not inject to EUT.

7-4 Setting When Capacitors Coupling

(1) To inject surge to Line - Line

Example: In case of injection line: [OUT1] and return line: [OUT2]

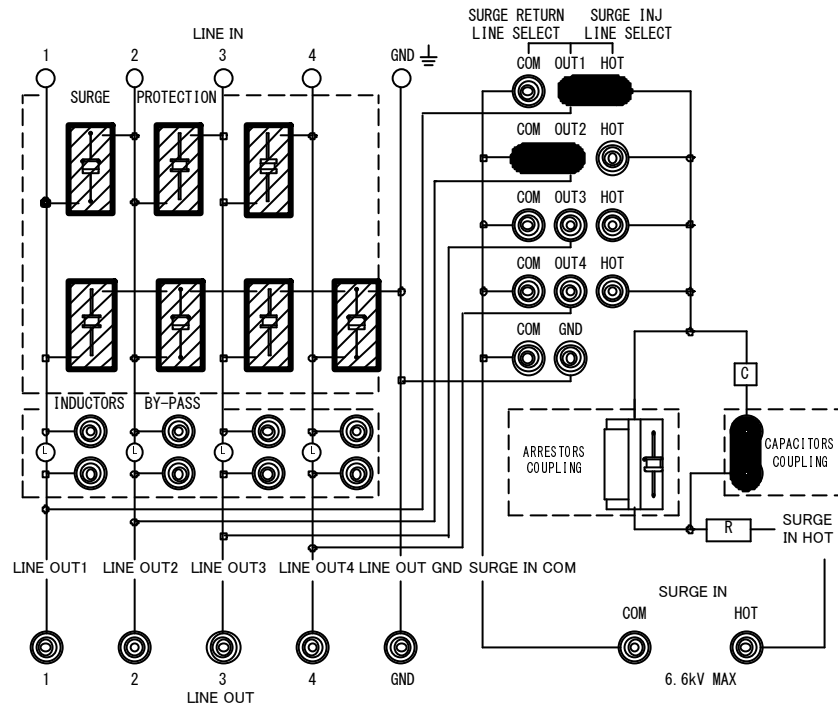

- ① Connect the connection plug (accessory) to [CAPACITORS COUPLING].
- ② Connect the connection plug to [SURGE INJ LINE SELECT] [SURGE RETURN LINE SELECT]. The above figure shows the example of setting [OUT1] as the surge injection line and [OUT2] as the surge return line.
- ③ The gas arrestor (90V) is connected to [SURGE PROTECTION]. Remove the gas arrestor or connecting another surge protection instrument depending on necessity.
*The gas arrestor is connected when shipped. The gas arrestor should be changed if it does not emit light when surge injected. In case of using surge absorbers etc other than the gas arrestor, connect a surge protection instrument depending on test conditions.
- ④ In case of bypassing the inductor (20mH) in the decoupling network, connect the connection plug (accessory) to [INDUTORS BY-PASS]. Never fail to bypass all lines.
*In case of bypassing the inductor (20mH), the surge may return to the line input side and damage EUT. Besides, the surge may not inject to EUT.

(2) To inject surge to Line-Ground

Example: In case of injection line: [OUT1] and return line: [GND].

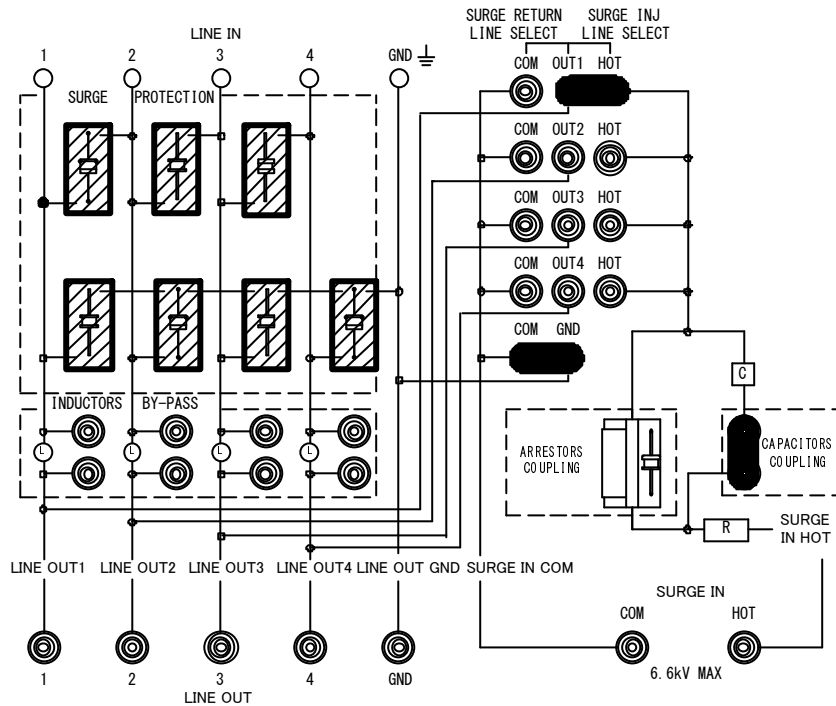

- ① Connect the connection plug (accessory) to [CAPACITORS COUPLING].
 - ② Connect the connection plug to [SURGE INJ LINE SELECT] [SURGE RETURN LINE SELECT]. The above figure shows the example of setting [OUT1] as the surge injection line and [GND] as the surge return line.
 - ③ The gas arrestor (90V) is connected to [SURGE PROTECTION]. Remove the gas arrestor or connecting another surge protection instrument depending on necessity.
*The gas arrestor is connected when shipped. The gas arrestor should be changed if it does not emit light when surge injected. In case of using surge absorbers etc other than the gas arrestor, connect a surge protection instrument depending on test conditions.
 - ④ In case of bypassing the inductor (20mH) in the decoupling network, connect the connection plug (accessory) to [INDUTORS BY-PASS]. Never fail to bypass all lines.
*In case of bypassing the inductor (20mH), the surge may return to the line input side and damage EUT. Besides, the surge may not inject to EUT.
- **When using the unit, never fail to turn off the line switch of LSS-6000 series.**
If AC or DC power is supplied to [HOT] and [COM] terminals of the unit from LSS-6000 series, the unit may cause combustion.

8. BLOCK CHART

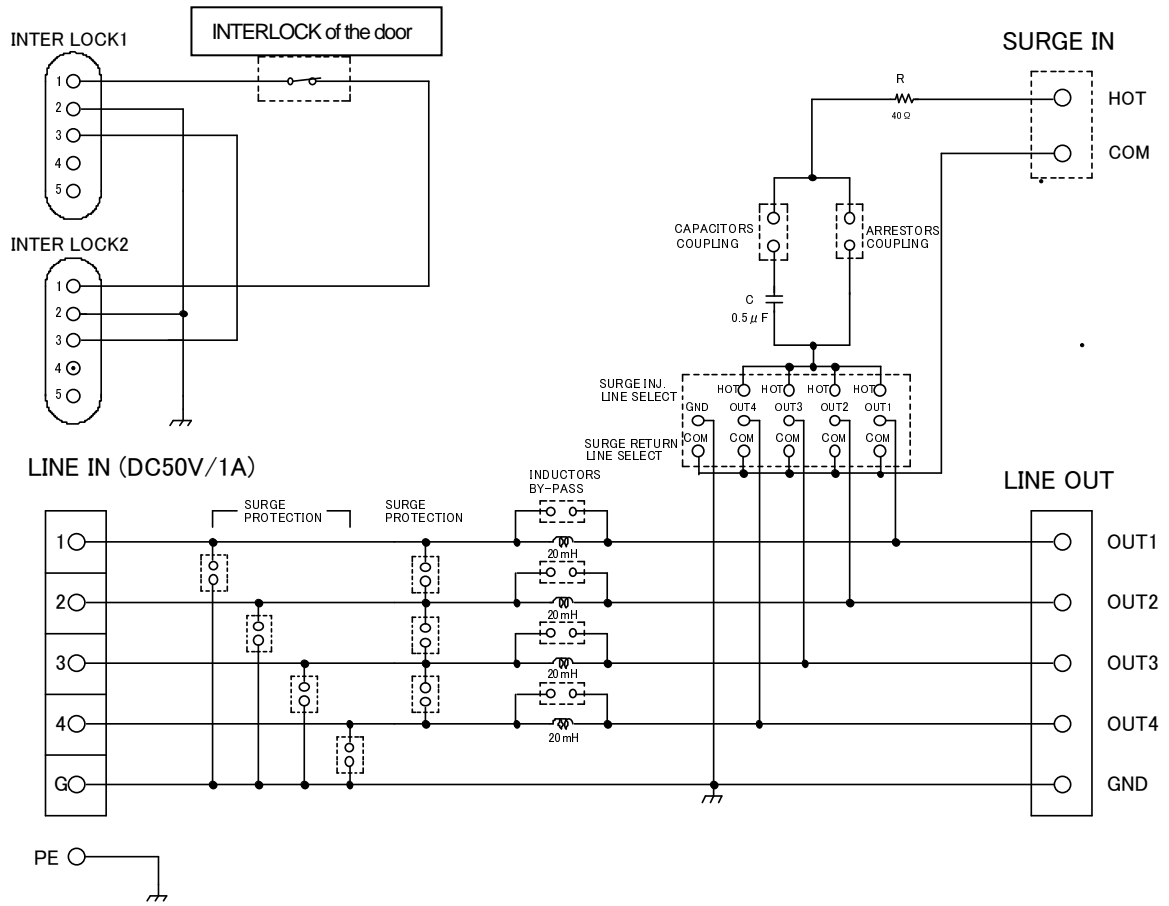

9. SPECIFICATIONS

Items	Specifications	Note
Surge Input Voltage	500V-6600V (Combination Wave)	
EUT Capacity	DC50V/1A	
The Number of Lines (Max.)	4 lines	
Decoupling Coil	20mH / each line	
Matching Resistance	40Ω ± 10%	
Dimension	W (488) x H(456) x D(550)mm	
Weight	Approximately 45kg	

The specifications and functions of the unit are subject to change without prior notice.

10. ACCESSORIES



A



B

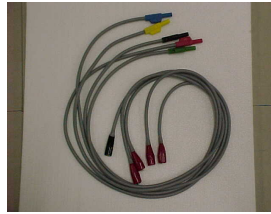

C



D



E



F



G



H



I

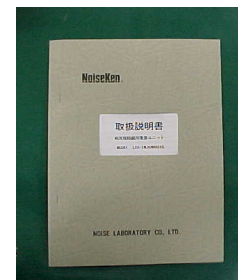

J

A: Accessory bag	1 pc
B: Surge In Cable (1m) *Used in connection with LSS-6000/6100...	2 pcs
C: Line Out Cable (1m).....	5 pcs
D: Surge In Cable (1m) *Used in connection with LSS-6230	2 pcs
E: Connection Plug	7 pcs
F: Capacitor / Gas Arrestor Unit.....	1 pc
G: Gas Arrestor Unit	1 pc
H: Interlock Connection Cable.....	1 pc
I: PE Cable (2m).....	1 pc
J: Instruction Manual	1 pc

*Two pairs of Surge In Cables are included. One type is with Multi-Contact safety sockets at both ends. This is used for LSS-6000/6100. The other type has a multi-Contact safety socket at one end and solderless terminal at the other end. This is for connection to LSS-6230.

11. WARRANTY

Servicing terms

The following terms are applicable to servicing by Noise Laboratory Co., Ltd., (hereafter referred to as the Company) provided to maintain the intended performance of its products.

1. Scope

The following terms shall apply only to products made by the Company.

2. Technical servicing fee

In the event of a failure of a product within the warranty period (see warranty section), the Company will repair a product without charge. After the warranty expires, repairs will be billed at a nominal cost.

3. Ownership of defective parts

Any defective part exchanged under the Company's servicing belongs to it.

4. Limited liability

In the event that damages resulting from servicing by the Company are intentional or caused by negligence, the Company will pay the cost but at the purchase value of the relevant product maximum. But, notwithstanding the foregoing, the Company shall not be responsible for any incidental or consequential damages of any nature, including without limitation thereof loss of would-be profit or compensation demanded from a third party.

5. Refusal to offer servicing

The company may not accept a repair order in the following cases:

- More than 5 years have passed since the product discontinued
- More than 8 years have passed after delivery
- Required component for servicing already discontinued and no alternative is available.
- Product changed, repaired or remodeled without obtaining a prior permission from the Company.
- Product severely damaged to the extent it has lost its original form

Limited warranty

Noise Laboratory Co., Ltd. (hereafter referred to as the Company) warrants its products to be free from defects in materials and workmanship under normal use and service for a period of one year from date of delivery. In the event of failure of a product covered by this warranty, the Company will repair the product or may, at its option, replace it in lieu of repair without charge.

Notwithstanding the foregoing, the Company shall not be responsible for any incidental or consequential damages of any nature, including without limitation thereof loss of would-be profit or compensation demanded from a third party. This warranty is valid only in Japan.

1. Scope

This warranty shall only apply to products made by the Company.

2. Period

One year from date of delivery. The warranty may be valid in 6 months after servicing if the same failure on the same component has repeated.

3. Exclusions

The followings are exclusions from this warranty:

- Consumable parts (including HV relay)
- Failure caused by misuse, neglect, accident or abnormal conditions of operation
- Failure caused by remodeling on the user side without prior permission from the Company
- Failure caused by servicing by unauthorized personnel by the Company
- Failure due to force majeure including but not limited to, acts of God, fire, war, riot, rebellion and others
- Failure due to shock or drop in or after transit
- Failure due to operation in environment being out of ambient specifications.
- A unit shipped to overseas.

12. MAINTENANCE

1. When repair, maintenance or internal adjustment of the unit is required, a qualified service engineer takes charge of such work.
2. Maintenance on the user side is restricted to the outside cleaning and functional check of the unit.
3. When replacing the fuses, turn off the switch of this unit and the connected equipment and disconnect the plug socket beforehand.
4. When cleaning the unit, turn off the switch of this unit and the connected equipment and disconnect the plug socket beforehand.
5. Avoid using chemicals for cleaning. Otherwise, the coating of the unit may peel off or the sight glass may be broken.
6. Do not open the cover of the unit.

13. NOISE LABORATORY SUPPORT NETWORK

- If a symptom which seems a trouble is found, inform the model name and serial number of the product together with the symptom to Noise Laboratory or your nearest sales agent of Noise Laboratory.
- When the product is returned to Noise Laboratory, write the state of the trouble, contents of your request, model name and serial number in a repair order, and pack the product and repair order sheet in the former package of equivalent suitable for transit and send them back.

NOISE LABORATORY CO., LTD.

1-4-4, Chiyoda, Chuo-ku, Sagami-hara City, Kanagawa Pref., 252-0237, Japan

TEL: +81-(0)42-712-2051 FAX: +81-(0)42-712-2050

URL: <http://www.noiseken.co.jp>

Printed in Japan