

# INSTRUCTION MANUAL

## DISCHARGE GUN for ELECTROSTATIC TESTING

MODEL GT-30R  
GT-30R330  
GT-30R2K  
GT-30R3302K

- Thank you very much for your purchasing this instrument.
- This instrument generates high voltage.  
Since failure to follow instructions for handling this instrument may cause an electric shock or other kinds of accidents, please be careful for safety in handling this instrument.
- Please read this booklet carefully, understand its content well to use this instrument safely and properly, and keep it by your side or other proper location so that it may be always readily available.

NOISE LABORATORY CO., LTD.

## NOTICE

- No part of this booklet may be reproduced or transferred, in any form, for any purpose, without the permission of Noise Laboratory Co., Ltd.
- The contents of this booklet have been thoroughly checked. However, if a doubtful point, an error in writing or a missing is found, please contact us.
- Noise Laboratory Co., Ltd. shall have no liability for any trouble resulting from the misuse or improper handling of this product regardless of the contents of this booklet or arising from the repair or remodeling of this product by a third party other than Noise Laboratory Co., Ltd. or its authorized person.
- Noise Laboratory Co., Ltd. shall have no liability for any trouble resulting from the remodeling or modification of this product.
- In no event shall Noise Laboratory Co., Ltd. be liable for any results arising from the use of this product.
- Trademarks, company names, and similar that appear in this document are trademarks or registered trademarks of their respective companies. This document does not use the TM and ® symbols.

# 1. IMPORTANT SAFETY PRECAUTIONS

The "Important Safety Precautions" explain rules that must be followed to prevent any risk of harm or injury to the user of the instrument or to other people.

- **The instrument may only be used by trained EMC technicians (electrical technicians)**

There is a risk of death or serious injury, and of the emission of electromagnetic noise that exceeds the stipulated limits. Please use the instrument in conjunction with appropriate measures for dealing with electromagnetic noise such as a Faraday cage or shielded room.

- **Do not use the instrument for any purposes other than the EMC testing purposes described in this instruction manual**

Failure to follow this rule risks death or serious injury.

- **The instrument may not be used by people fitted with electronic medical devices such as pacemakers and such people may not enter the testing site while the instrument is operating**

Failure to follow this rule risks death or serious injury.

- **The instrument may not be used in a location where fire is prohibited or there is a risk of explosion**

Failure to follow this rule risks igniting a fire due to an electrical discharge.

Before setting up the test site, connecting the equipment, or starting testing, please read the Chapter entitled "Basic Safety Precautions for the Safe Use of the Simulator" which contains additional safety advice.

## 2. CHECK PACKAGE CONTENTS

Before using the instrument, please check that none of the main unit and associated items are missing.

This product can be used to perform the tests that conform to different test standards by changing the CR unit and discharge cup.

For that reason, the product is available in four different sets. This section shows what is supplied with each set. Read it according to the contents of your set.

- 2-1. GT-30R (Set for Test under IEC 61000-4-2)
- 2-2. GT-30R2K (Set for 2k $\Omega$  Test under ISO 10605)
- 2-3. GT-30R330 (Set for 330 $\Omega$  Test under ISO 10605)
- 2-4. GT-30R3302K (Set for 330 $\Omega$  & 2k $\Omega$  Test under ISO 10605)

### 2-1. GT-30R (Set for Test under IEC 61000-4-2)

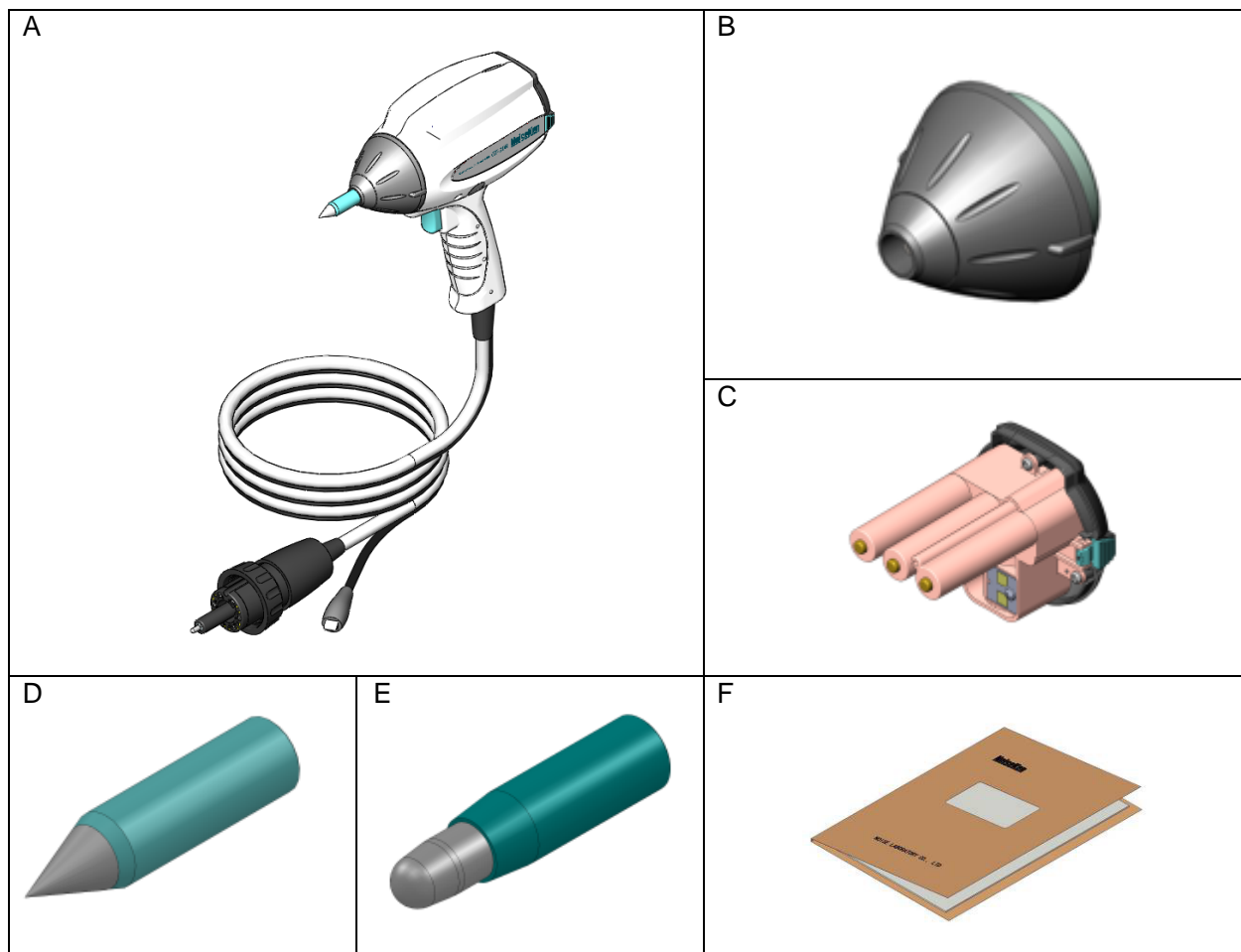

Item	Quantity
A: Main unit of the discharge gun .....	1
B: 330 $\Omega$ testing discharge cup (Attached to the main unit).....	1
C: CR unit 150pF-330 $\Omega$ (Attached to the main unit) .....	1
D: Contact discharge tip (Conical) .....	1
E: Air discharge tip (Round) .....	1
F: Instruction manual (This book) .....	1

2-2. GT-30R2K (Set for 2kΩ Test under ISO 10605)

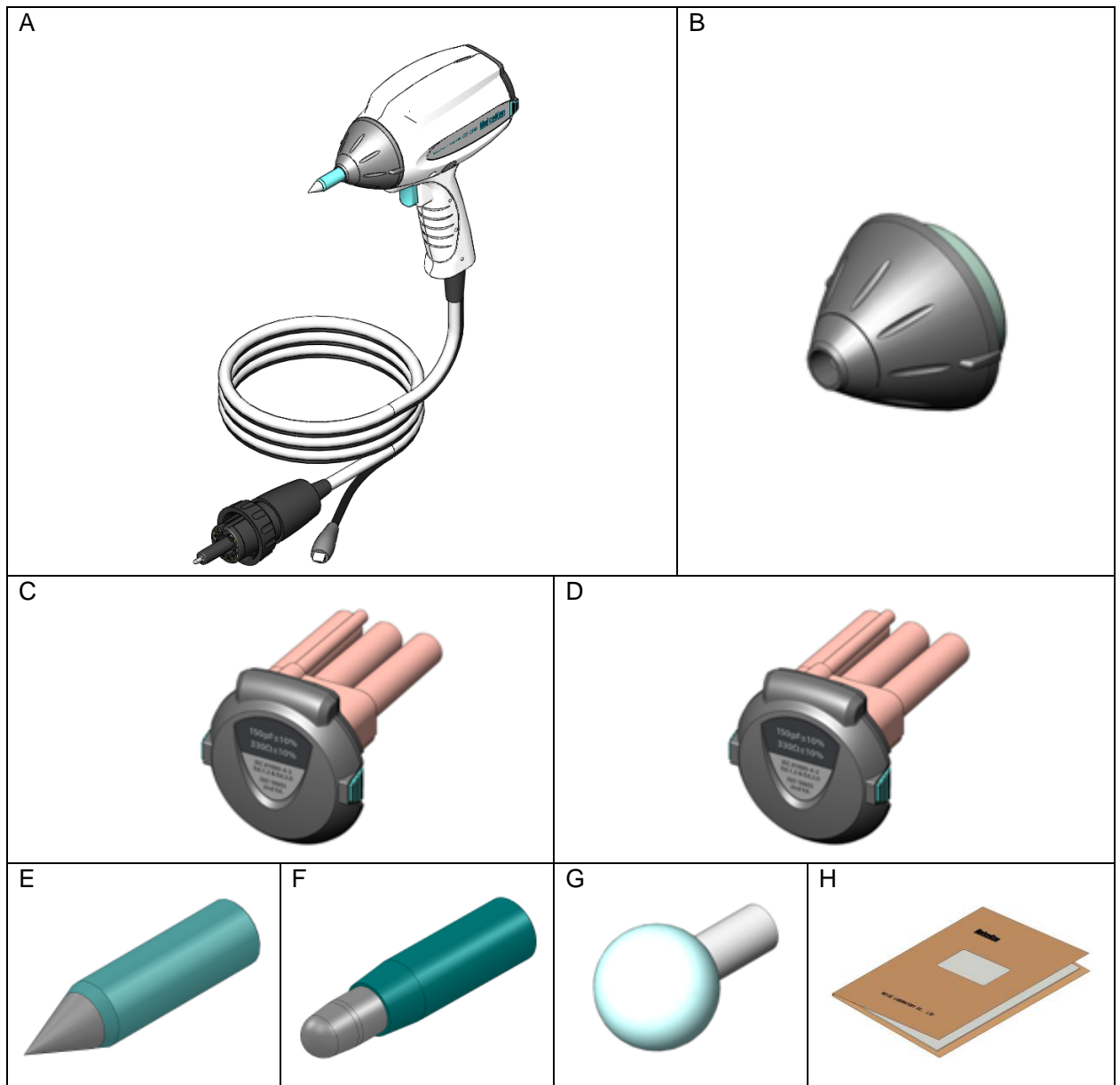

Item	Quantity
A: Main unit of the discharge gun .....	1
B: 2kΩ testing discharge cup (Attached to the main unit) .....	1
C: CR unit 150pF-2kΩ (Attached to the main unit) .....	1
D: CR unit 330pF-2kΩ .....	1
E: Contact discharge tip (Conical) .....	1
F: Air discharge tip (Round) .....	1
G: High voltage air discharge tip (SphericalΦ30mm) .....	1
H: Instruction manual (This book).....	1

2-3. GT-30R330 (Set for 330Ω Test under ISO 10605)

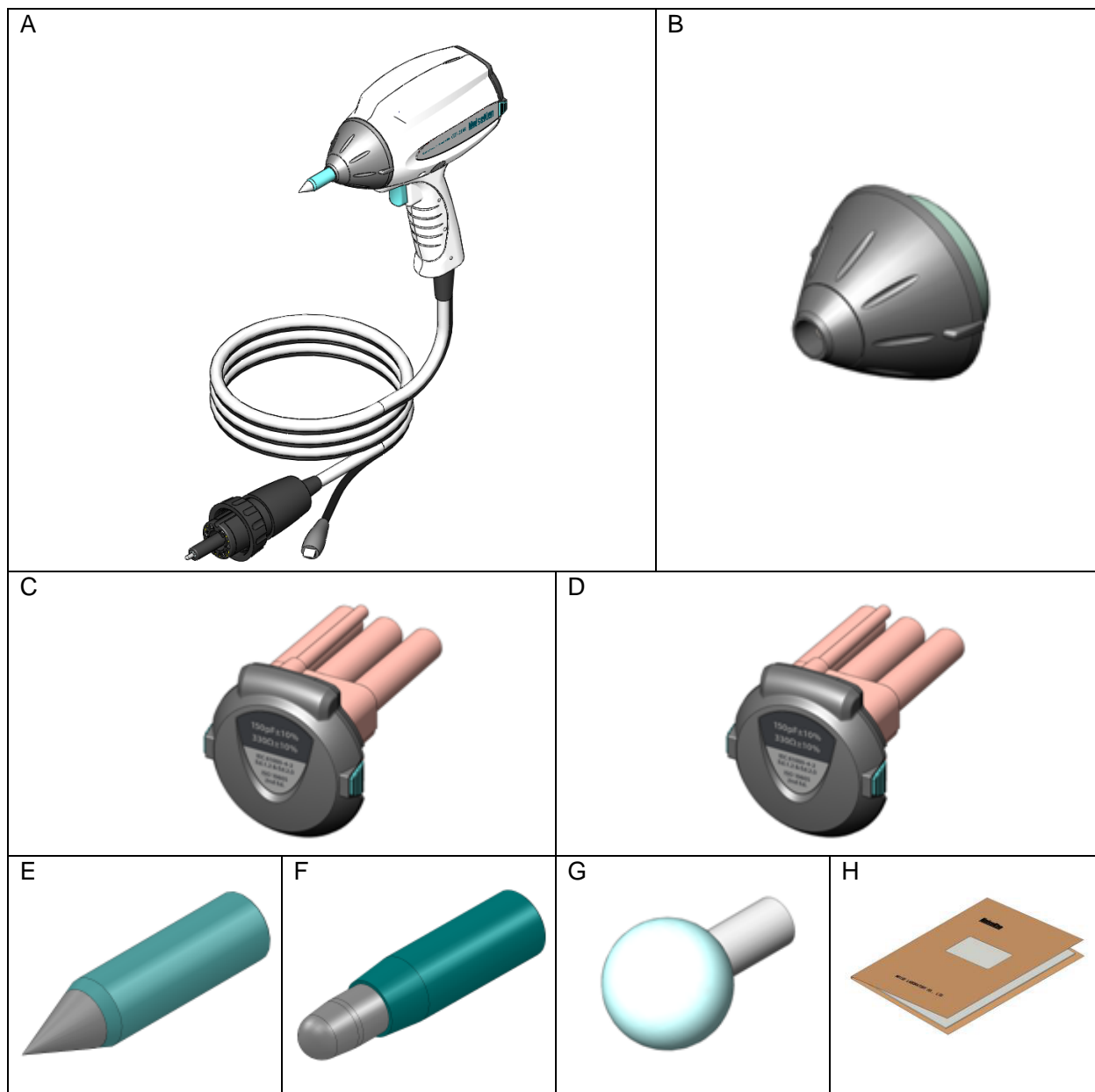

Item	Quantity
A: Main unit of the discharge gun .....	1
B: 330Ω testing discharge cup (Attached to the main unit).....	1
C: CR unit 150pF-330Ω (Attached to the main unit) .....	1
D: CR unit 330pF-330Ω.....	1
E: Contact discharge tip (Conical) .....	1
F: Air discharge tip (Round).....	1
G: High voltage air discharge tip (SphericalΦ30mm) .....	1
H: Instruction manual (This book).....	1

2-4. GT-30R3302K (Set for 330 Ω & 2kΩ Test under ISO 10605)

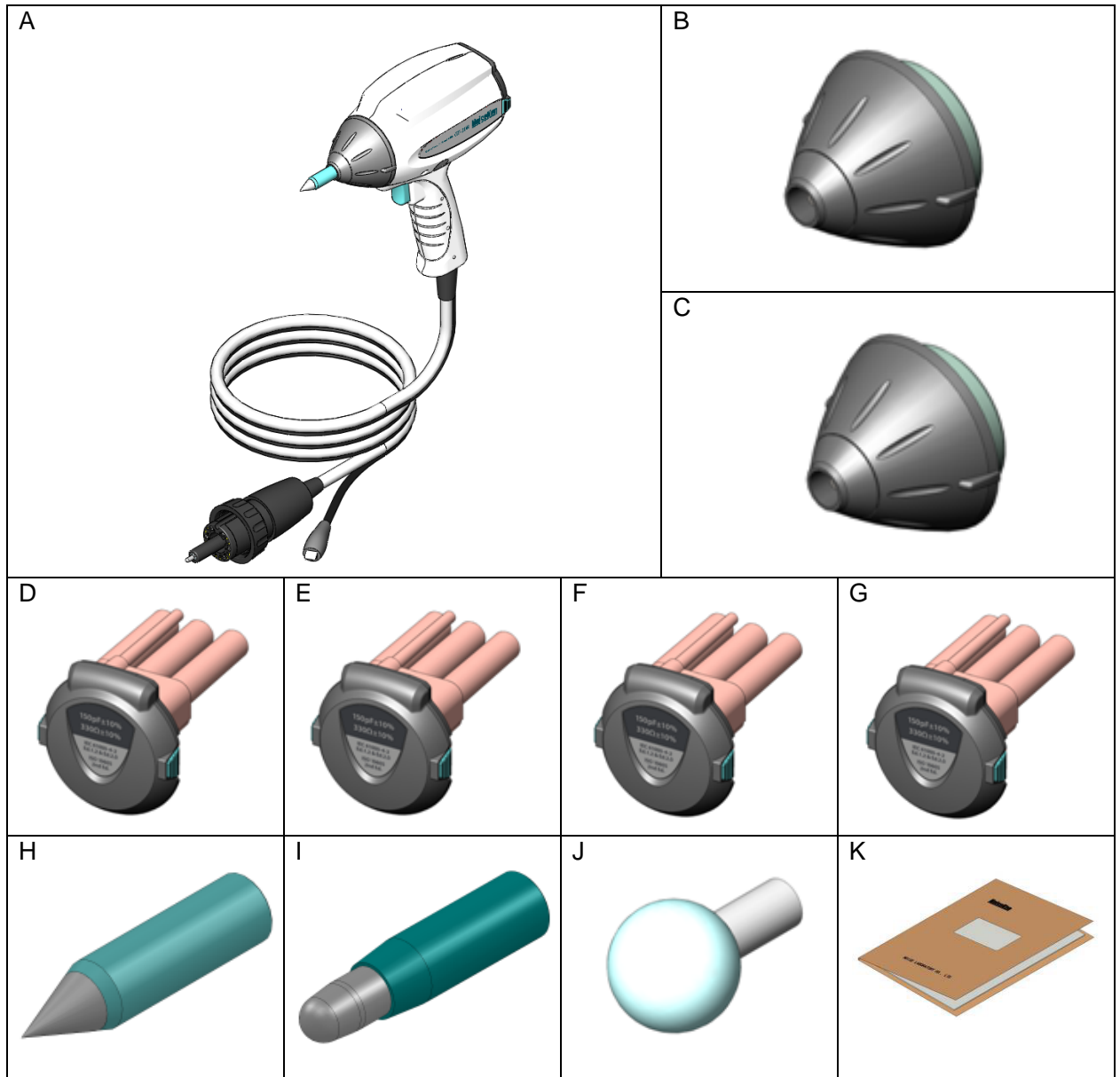

Item	Quantity
A: Main unit of the discharge gun .....	1
B: 330Ω testing discharge cup (Attached to the main unit).....	1
C: 2kΩ testing discharge cup .....	1
D: CR unit 150pF-330Ω (Attached to the main unit) .....	1
E: CR unit 150pF-2kΩ .....	1
F: CR unit 330pF-2kΩ.....	1
G: CR unit 330pF-330Ω .....	1
H: Contact discharge tip (Conical).....	1
I: Air discharge tip (Round) .....	1
J: High voltage air discharge tip (SphericalΦ30mm).....	1
K: Instruction manual (This book).....	1

### 3. APPLICATION FORM FOR INSTRUCTION MANUAL

To: Noise Laboratory Co., Ltd. via sales agent

We place an order for an instruction manual.

Model Name

Serial No.

--	--	--	--	--	--	--	--	--	--

Applicant Address

\_\_\_\_\_

\_\_\_\_\_

\_\_\_\_\_

Company Name

Department

Contact Person

Phone No.

FAX No.

\_\_\_\_\_

\_\_\_\_\_

\_\_\_\_\_

\_\_\_\_\_

\_\_\_\_\_

Cut off this page "**PURCHASE ORDER FOR INSTRUCTION MANUAL**" from this volume and **keep it for future use with care.**

When an INSTRUCTION MANUAL is required, fill in the above Application Form and mail or fax it to your nearest sales agent of Noise Laboratory or Noise Laboratory.





## 4. TABLE OF CONTENTS

<b>1. IMPORTANT SAFETY PRECAUTIONS</b> .....	<b>1</b>
<b>2. CHECK PACKAGE CONTENTS</b> .....	<b>2</b>
2-1. GT-30R (Set for Test under IEC 61000-4-2).....	2
2-2. GT-30R2K (Set for 2k $\Omega$ Test under ISO 10605).....	3
2-3. GT-30R330 (Set for 330 $\Omega$ Test under ISO 10605).....	4
2-4. GT-30R3302K (Set for 330&2k $\Omega$ Test under ISO 10605).....	5
<b>3. APPLICATION FORM FOR INSTRUCTION MANUAL</b> .....	<b>6</b>
<b>4. TABLE OF CONTENTS</b> .....	<b>8</b>
<b>5. PREFACE</b> .....	<b>10</b>
5-1. Features.....	10
5-2. Combinations with Simulators.....	10
<b>6. BASIC SAFETY PRECAUTIONS FOR THE SAFE USE OF THE SIMULATOR</b> .....	<b>11</b>
6-1. Meaning of Safety Symbols.....	11
6-2. DANGER Alerts.....	12
6-3. WARNING Alerts.....	12
6-4. CAUTION Alerts.....	14
<b>7. POINTS TO NOTE REGARDING CONSUMABLES ITEMS</b> .....	<b>16</b>
7-1. High Voltage Relay.....	16
7-2. Discharge Tip.....	16
7-3. CR Unit.....	16
<b>8. INTRODUCTION</b> .....	<b>17</b>
8-1. How to Read This Document.....	17
8-2. Terms and Definitions.....	18
<b>9. NAME AND FUNCTION OF EACH PART</b> .....	<b>19</b>
9-1. External Appearance and Descriptions.....	19
<b>10. SIMULATOR MAIN UNIT AND CONNECTIONS</b> .....	<b>23</b>
10-1. Connection to The Simulator Main Unit.....	24
<b>11. HOW TO REPLACE COMPONENT UNITS</b> .....	<b>25</b>
11-1. Discharge Cup.....	25
<i>Combination of Discharge Cup and CR Unit</i> .....	25
<i>Replacing Discharge Cup</i> .....	26
11-2. Discharge Tip.....	27
<i>Types of Discharge Tips and Their Applications</i> .....	27
<i>Replacing Discharge Tip</i> .....	28
11-3. CR Unit.....	29
<i>Replacing CR Unit</i> .....	29
11-4. GND Clip.....	30
<b>12. OPERATION</b> .....	<b>31</b>
12-1. Starting Test.....	31
12-2. LED Light.....	32
12-3. Stopping a Test.....	32

<b>13. SPECIFICATIONS.....</b>	<b>33</b>
13-1. List of Specifications.....	33
13-2. Discharge Parameters and Waveform (150pF-330Ω, 330pF-330Ω) .....	34
13-3. Discharge Parameters and Waveform (150pF-2000Ω, 330pF-2000Ω) .....	35
<b>14. CHECKING WAVEFORM.....</b>	<b>36</b>
14-1. Equipment and Configuration.....	36
14-2. Accessories for Observing Waveform .....	36
<b>15. RELATED ACCESSORIES .....</b>	<b>37</b>
<b>16. CALIBRATION .....</b>	<b>38</b>
<b>17. WARRANTY .....</b>	<b>39</b>
<b>18. MAINTENANCE .....</b>	<b>41</b>
<b>19. CONTACTING TECHNICAL SUPPORT .....</b>	<b>42</b>

## 5. PREFACE

Thank you very much for your purchase of the discharge gun for electrostatic discharge testing “GT-30R”. It is recommended that the contents of this manual should be thoroughly understood and used as a ready reference for operation.

To ensure the safety and procedure of electrostatic tests, thoroughly read this Instruction Manual together with the instruction manual for Electrostatic Discharge Simulator to be connected to this product.

- **This Instruction Manual was prepared so that any person who can observe the prescribed instruction method and operating precautions may safely handle and fully utilize this discharge gun.**
- **Keep this Instruction Manual by your side or other proper location so that it may be readily available when using this discharge gun.**

### 5-1. Features

This product is an electrostatic discharge gun conforming to IEC 61000-4-2 and is designed to generate static electricity for conducting the electrostatic discharge immunity test. When conducting the electrostatic test, this product should be connected to the Noiseken’s Electrostatic Discharge Simulator (e.g. ESS-S3011, ESS-B3011).

Changing the discharge cup and CR unit makes it possible to perform the electrostatic discharge immunity test conforming to ISO 10605.

As for conforming standard and combination of the units, refer to Table 11.1, Table 11.2, 13.SPECIFICATIONS and 15.RELATED ACCESSORIES.

### 5-2. Combinations with Simulators

This product is a discharge gun used to perform electrostatic tests. Its available functions vary, depending on the simulator used in the combination with it.

Simulator model	Connectivity/Availability	Functional restriction on this instrument
ESS-S3011	⊙	No functional restrictions
ESS-B3011	⊙	
ESS-2000AX	○	● The following functions are not available. <ul style="list-style-type: none"><li>▪ Discharge detection</li><li>▪ Pre-check</li><li>▪ LED light illuminating EUT</li><li>▪ CR &amp; cup combination recognition</li></ul>
ESS-2002EX	○	
ESS-2000	○	
ESS-2002	○	

⊙: Recommended combination, which can be connected and used without any functional restriction.



○: Can be connected and used but some functions are not available.

## 6. BASIC SAFETY PRECAUTIONS FOR THE SAFE USE OF THE SIMULATOR











- The "Basic Safety Precautions" explain rules that must be followed to prevent damage to property or injury to the user of the instrument or to other people.
- The symbols below are used to indicate the level of injury or damage that may result if the instrument is used in a way that ignores these precautions. Please take careful note of the meanings of these symbols before proceeding to read this manual.

### 6-1. Meaning of Safety Symbols

- ◆ The following symbols indicate the level of injury or damage that may result if the instrument is used incorrectly in a way that ignores the associated precautions.

 <b>DANGER</b>	<p>This symbol indicates that failure to comply with the associated precaution "is highly likely to result in the risk of death or serious injury".</p>
 <b>WARNING</b>	<p>This symbol indicates that failure to comply with the associated precaution "may result in death or serious injury".</p>
 <b>CAUTION</b>	<p>This symbol indicates that failure to comply with the associated precaution "may result in damage but that only physical damage is likely to occur".</p>

- ◆ The following symbols indicate the nature of the associated precaution.

	<p>Indicates a warning (a situation where caution is required).</p>		
	<p>Indicates a prohibition (an action that is not allowed to occur).</p>	 Prohibited	 Disassembly Prohibited
	<p>Indicates an instruction (an action that must always be taken).</p>	 Safety Rule	 Always earth correctly
		 Unplug from Mains Power	

### 6-2. DANGER Alerts

---



Disassembly  
Prohibited

- **Do not disassemble or modify**  
**Do not remove the cover**

Failure to comply with the precaution may result in death or serious injury and possible consequences include fire and electric shock.

For inspection or repair of internal components, please contact your sales agent or the Noise Laboratory repair and calibration center.

### 6-3. WARNING Alerts

---



Unplug from Mains Power

- **Stop using the instrument immediately if any of the following problems occur**
  - Unit emits smoke and an unusual smell
  - Water or other foreign material has got inside the unit
  - Unit is dropped or damaged
  - AC power cable is damaged (possibly exposing or disconnecting the wires, etc.)

Continuing to use the instrument in a faulty condition risks causing fire, electric shock, or similar. Disconnect from the power supply immediately and unplug the AC plug from the socket.

After confirming that no more smoke is being emitted, send the instrument to your sales agent or the Noise Laboratory repair and calibration center for repair. Repairing the instrument yourself is dangerous and should never be attempted.



Safety Rule

- **Turn the power switch to "Off" on the instrument before connecting or changing any of the cables**

Failure to comply with this rule may result in electric shock or misoperation.



## Safety Rule

- **Only use the instrument with a power supply voltage and frequency that is within the indicated range (AC 100V to 240V, 50Hz/60Hz)**  
Using the instrument with a power supply voltage or frequency outside the indicated range may result in fire or electric shock.
- **Firmly insert the AC power cable plug into the socket**  
Failing to fully insert the plug may result in heating or the build-up of dust leading to fire, electric shock, or similar.  
Plugging too many cables into the same power outlet may also cause cables to overheat leading to fire, electric shock, or similar.



## Always earth correctly

- **Plug the AC power cable into a socket that has a protective earth terminal**  
The AC power cable provided with the instrument has a three-pin plug that connects to the power supply and protective earth terminal.  
The protective earth on the three-pin plug connects via the AC power cable to the metal parts on the instrument.  
Because this provides protection from electric shock, ensure that you plug the power supply cable into a socket that has a properly earthed protective earth terminal.  
Using the instrument without a protective earth connection may result in electric shock.



## Prohibited

- **Do not insert objects into the instrument or its connectors**  
Inserting metallic or flammable items into the ventilation slits, connectors, or other openings may result in fire, electric shock, or similar.
- **Do not touch the tip of the discharge gun while the instrument is operating**  
Failure to comply with this rule may result in electric shock or injury.
- **Do not aim at a person during testing**  
This is very dangerous and may result in unexpected injury so should never be attempted.
- **Do not install in a location that obstructs access to the power supply, STOP, and other switches**  
Failure to comply with this rule may prevent you from reacting quickly when a problem occurs and may result in fire or electric shock.
- **Do not use the AC power cable for any purpose other than this instrument**  
The supplied AC power cable is only intended for use with this instrument. Do not use it for any purpose than this instrument. Use on any other electrical equipment risks overheating leading to fire, electric shock, or similar. Similarly, using an AC power cable from another electrical device may prevent the instrument from operating at its intended level of performance and may result in overheating if the current carrying capacity of the cable is insufficient, leading to fire, electric shock, or similar.

- **Do not damage the AC power cable**

Damage to the AC power cable may result in fire, electric shock, or similar. Take particular care in relation to the following precautions.

- Do not manipulate the AC power cable
- Do not bend the AC power cable excessively
- Do not twist the AC power cable
- Do not pull the AC power cable
- Do not locate the AC power cable close to a heater
- Do not place heavy objects on the AC power cable

#### 6-4. CAUTION Alerts

---



**CAUTION**



Safety Rule

- **If condensation appears after the instrument is moved from a cold to a warm location, allow to dry naturally before using**  
Using the instrument while condensation is present may result in electric shock, faults, or fire.
- **Clean the AC plug periodically**  
Allowing dust or dirt to accumulate between the AC plug and socket and absorb moisture may reduce the electrical insulation and result in fire. Periodically unplug the AC plug from the mains socket and clean off any dirt or dust using a dry cloth.
- **Clean the high-voltage input and output connectors periodically**  
Allowing dust or dirt to accumulate between the high-voltage input connector and high-voltage output connector and absorb moisture may reduce the electrical insulation and result in fire. Periodically unplug the AC plug from the mains socket, wait for five or more seconds, then unplug the high-voltage input connector from the high-voltage output connector and blow dehumidified air into the high-voltage output connector to clean out any dust or dirt. Also clean off any dirt or dust on the high-voltage input connector using a dry cloth.
- **If the instrument becomes dirty, clean with a dry cloth**  
Never use benzene, thinner or other solvents as these may degrade the exterior surface or printed text.  
If the exterior, operation panel, or other parts of the instrument become dirty, wipe with a dry soft cloth. If the dirt is difficult to remove, moisten the cloth with water or apply a small quantity of a neutral detergent to the cloth. Wipe dry after using these to clean the instrument.
- **Ensure that the safety warning labels are always visible**  
If the safety warning labels become dirty or start to peel off, please reattach them for safety. If the labels are lost, please contact your sales agent or the Noise Laboratory repair and calibration center for replacements.
- **The twisted cable must be repaired**  
Don't use or keep cable when it is twisted. There is possibility that cable is disconnected internally.





Prohibited

- **Do not use the instrument with other than a recommended discharge gun**  
Using the instrument with other than a recommended discharge gun may result in poor operation and abnormal test results.
- **Do not apply static electricity to the instrument itself**  
Failure to comply with this rule may cause the instrument to become faulty.
- **Do not install the instrument in any of the following locations**  
Installing the instrument in any of the following locations may result in fire, electric shock, and similar.
  - Humid or dusty environments
  - Locations where the instrument is likely to become hot such as close to a heater or exposed to direct sunlight
  - Locations where the instrument is likely to get wet such as next to a window
- **Do not block the ventilation slits or use in a location with poor ventilation**  
Do not block the ventilation slits on the instrument. Blocking the ventilation slits causes heat to build up inside the unit which may lead to fire. Take particular note of the following precautions.
  - Do not lie the unit face up, on its side, or upside down
  - Do not position in cramped locations with poor ventilation
  - Allow a gap of at least 10cm from walls and similar when installing
- **Do not unplug the high-voltage input connector by pulling on the cable**  
Failure to comply with this rule may damage the cable, resulting in faults or fire.  
Hold by the high-voltage connector when unplugging.
- **Do not operate the instrument or insert or remove the AC plug or high-voltage input connector if you have wet hands**  
Failure to comply with this rule may result in electric shock or faults.
- **Do not place water-filled containers on the instrument**  
If the water is spilt and gets inside the instrument it may result in fire or electric shock.
- **Do not drop or subject to strong physical shocks**  
Failure to comply with this rule may result in faults.
- **Do not knock or scratch with hard objects**  
Such actions may damage the exterior coating or LCD panel.

\* If this instrument becomes faulty during normal use, it will be repaired in accordance with the terms of the warranty. However, please note that Noise Laboratory Co., Ltd. and its sales agents accept no liability for any compensation for losses or similar, or damage to the EUT (Equipment Under Test) or other peripheral equipment, caused by faults in the instrument, deterioration of consumables, or other external causes.

## 7. POINTS TO NOTE REGARDING CONSUMABLES ITEMS

### 7-1. High Voltage Relay

---

- This product contains the high-voltage relay.
- The high-voltage relays are consumable items. The electrical contacts in the high-voltage relays deteriorate with use and this can result in poor electrical connections, contact welding, or insulation failure occurring during normal use.
- If you experience problems such as being unable to apply a static discharge after starting a test or a static discharge occurs as soon as a high voltage is output, the cause may be deterioration of a high-voltage relay. In this case, please contact your sales agent or the Noise Laboratory repair and calibration center.  
Do not attempt to repair the instrument yourself as this is very dangerous.

### 7-2. Discharge Tip

---

- The discharge tips are supplied with this product.
- The discharge tips are consumable items. The surface of the discharge tip is being worn away with repeating contacting and discharging.  
In case of the contact discharge tip, especially, the sharp point of it becomes so dull that it cannot pierce the insulation coating of EUT and a proper contact discharge test cannot be conducted.  
In such a case, it must be replaced. Noise Laboratory sells individual new discharge tips.

### 7-3. CR Unit

---





- The CR unit is attached to this product.
- The CR unit is a consumable item. The characteristics of the CR unit is changing with repeating discharge, and in some cases, capacitance or resistance can become out of the tolerance described on the specification even in normal usage.  
Therefore, periodic calibration is recommended. For such calibration and replacement, please contact our sales agent or the Noise Laboratory repair and calibration center. Noise Laboratory sells individual new CR units.

## 8. INTRODUCTION

### 8-1. How to Read This Document

---

The symbols used in this document and their explanations are shown below.

	Indicates a supplementary explanation.
	Indicates where to refer to.
	Indicates that there is a setting restriction.
	Indicates that it must be checked before use.
<b>[ ]</b>	Indicates what is stated on the panel of the simulator.
[ ]	Indicates what is shown on the display section of the simulator.

## 8-2. Terms and Definitions

Term	Definition
EMC	Abbreviation of <u>E</u> lectro <u>M</u> agnetic <u>C</u> ompatibility. The concept which is generally required on electronic products and devices as a basic ability to radiate emission within the limit and to have enough immunity against external disturbances.
EMC technician	A person who has enough skill and knowledge in EMC field. In this manual, this term means especially a person who understands methods of ESD immunity testing well.
Protective earth terminal	An exclusively used terminal to ground a part of the electronic product, such as chassis, etc., where is likely to be touched by a human body, for preventing an electric shock in case of internal electric leakage of the product.
EUT	<u>E</u> quipment <u>U</u> nder <u>T</u> est. Equipment to be tested by test equipment.
Electrostatic discharge (ESD) immunity test	A category of immunity test which simulates electrostatic discharge phenomenon that a charged human body or object discharges to an electronic product.
Contact discharge	A method of the ESD immunity testing in which the discharge tip of the discharge gun is kept in contact with the EUT or coupling plane and the discharge is actuated by the discharge switch of the simulator. It is an unrealistic phenomenon in nature, but enables the test more reproducible.
Air discharge	A method of the ESD immunity testing in which the discharge tip of the discharge gun is moved towards the EUT until the tip touches the EUT. It is closer to natural phenomenon but has an unstable elements since it is dependent on test environment due to discharge in the air.
Discharge gun	A part of the simulator including charging and discharging circuit. One-hand handling is available.
CR unit	A part of the discharge gun equipped a charge capacitor (C) and a discharge resistor (R). The unit should be exchangeable to change the constant values of C and R on the circuit according to the standard requirement.
Gun head	A head part of the discharge gun. There are mainly two types, for IEC standard and for ISO standard. It should be exchanged according to the standard.
Discharge tip	Literally a "tip" part of the discharge gun. There are mainly two types, a conical type for contact discharge and a round type for air discharge.

## 9. NAME AND FUNCTION OF EACH PART

### 9-1. External Appearance and Descriptions

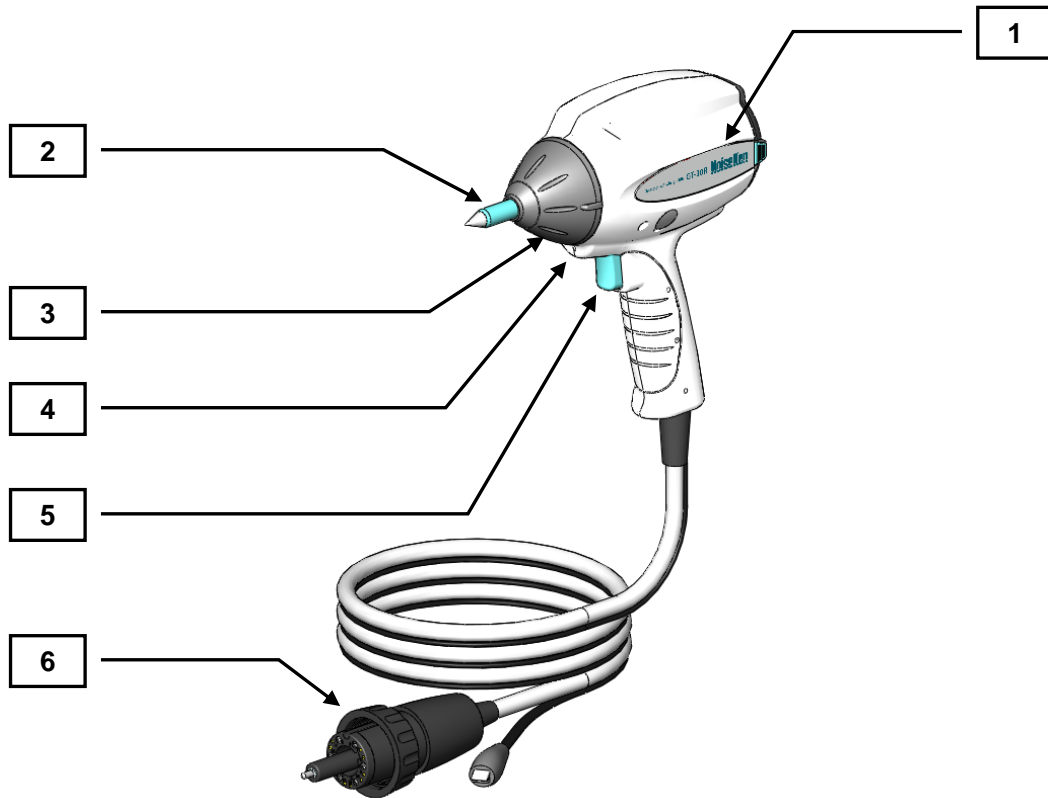

**Figure 9.1 Appearance-1**

- 1** Model number label  
Indicates Noiseken's logo, product name and model number.
- 2** Discharge tips  
Electrode tips used to perform electrostatic discharges.  
Use the three types of electrode tips according to what need to be tested.

These discharge tips are screw-in types, which can be replaced.

For details of how to replace them, see **0. 11-2. Discharge Tip**.



- Conical discharge tip  
For contact discharge test

Conforming to IEC and ISO



- Round discharge tip  
For air discharge test

Conforming to IEC and ISO

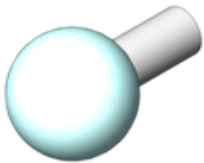

- Spherical discharge tip:  $\Phi 30\text{mm}$   
For high voltage (over 15kV) air discharge

Conforming to ISO

\* The spherical discharge tip is only supplied with the ISO 10605 test set (MODEL: GT-30R330, GT-30R2K)

**3** Discharge cup

Adjusts output waveform.

For ISO tests, the discharge cup must be changed along with the CR unit.

Discharge cups are screw-in types, which can be replaced.

For details, see **11-1. Discharge Cup**.

**4** LED light

White LED light used to illuminate EUT.



With NoiseKen's previous simulator models such as ESS-2000AX, the LED light cannot be turned on.

---

**5** Trigger switch

Starts electrostatic discharge.

The operation varies, depending on the setting of the combined simulator.

**6** High voltage input connector

Connects to the high voltage output connector of the main unit of the simulator.

It can also be connected to NoiseKen's previous simulator models such as ESS-2000AX.

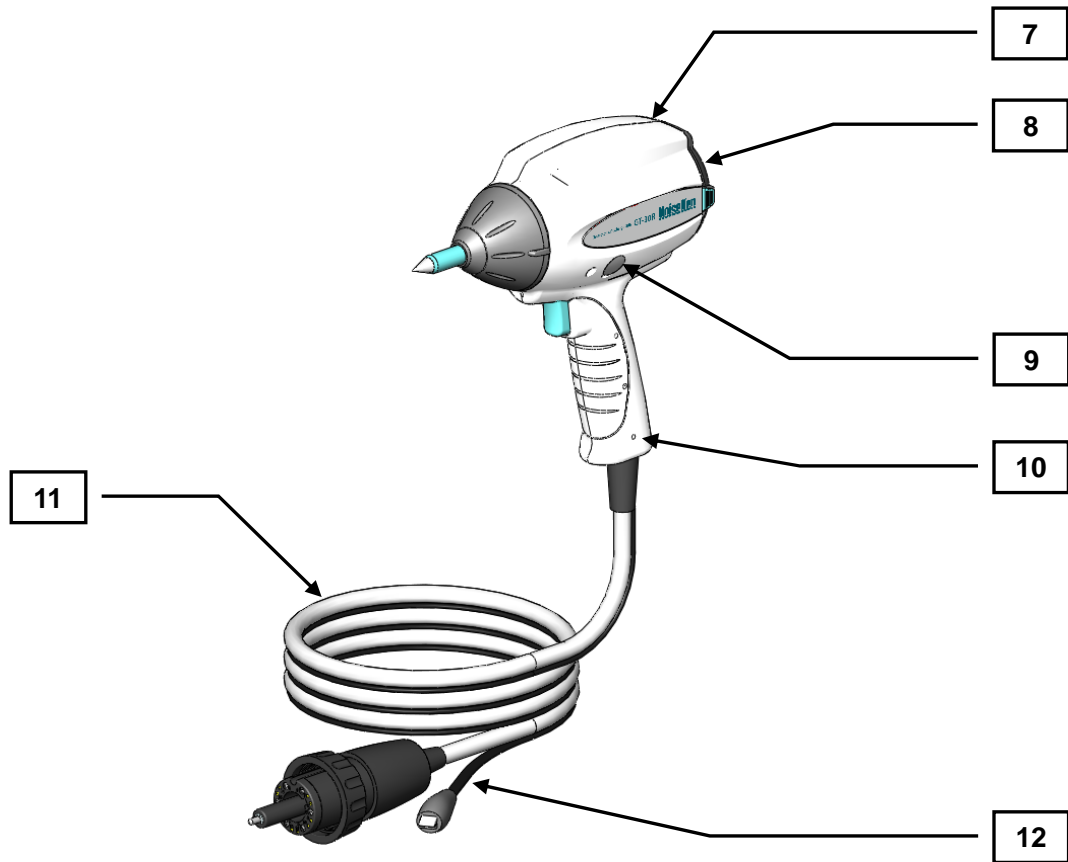

**Figure9.2 Appearance-2**

The serial number label and inspection certification label are placed where the CR unit **8** is attached.

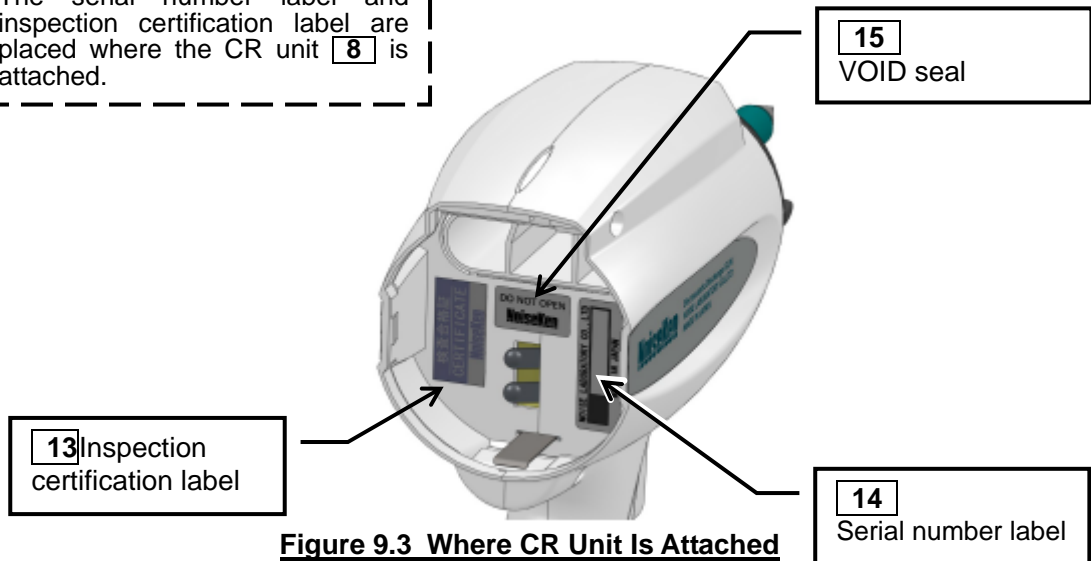

**Figure 9.3 Where CR Unit Is Attached**

**7** Status display lamp

It is turned on in red, when the start switch is pressed on the main unit of the simulator.  
If the discharge detection function on the main unit is set to [ON], it is turned on in green when a discharge is detected.

---



With NoiseKen's previous simulator models such as ESS-2000AX, the light is turned on only in red.

---

**8** CR unit

The CR unit contains an energy storage capacitor for electrostatic discharges and a discharge resistor.  
It can be replaced according to the test standard and what needs to be tested.  
For information about how to replace it, see **0. 11-3. CR Unit**.

**9** Optional ground terminal

The ground terminal is used to attach NoiseKen's optional products (impulse field adaptor, etc.).

**10** Probe stand mounting hole

The hole is used to mount the gun to the probe stand.

**11** High voltage cable

Connects the gun to the main unit (Approx. 2m).

---



Don't use or keep cable when it is twisted.  
There is possibility that cable is disconnected internally.

---

**12** GND cable

This ground return cable serves as the return channel for electrostatic discharges.  
The alligator clip at the end can be detached and screwed in to the ground plane.  
For details, see **11-4. GND Clip**.

---



Make sure to connect the GND cable to the ground plane.  
Failure to comply with this rule may result in electric shock or injury.

---

**13** Inspection certification label

Label certifying that the instrument passed the Noise Laboratory delivery inspection.

**14** Serial number label

Indicates serial number of this product.  
Placed where the CR unit is attached to the product, this label can be checked by removing the CR unit.

**15** VOID seal

Attached to avoid unauthorized detachment. If it is peeled off, the history is recorded.



## 10. SIMULATOR MAIN UNIT AND CONNECTIONS

### **WARNING**

- **Be sure to turn off the power supply of the main unit when connecting the discharge gun to the main unit or changing setup of equipment.**  
Failure to comply with this rule may cause an electric shock, an injury, or malfunction.
- **Be sure not to insert stuff into the main unit.**  
If something metallic or burnable goes into the main unit through the connector part or the vent, it might cause an electric shock or a fire.

### **CAUTION**

- **Be sure not to use this product with the ESD simulator main unit other than the recommendable models.**  
Failure to comply with this rule may cause malfunction or wrong test results.
- **Clean the HV connectors periodically**  
Allowing dust or dirt to accumulate between the HV input connector and the HV output connector and absorb moisture may reduce the electrical insulation and result in fire.  
Periodically unplug the HV input connector from the HV output connector, and clean off any dirt or dust using a dry cloth. As for the HV output connector, more than 5 seconds after unplugging the AC plug if the main unit, blow dehydrated air to it to blow off dirt and dust.
- **Do not unplug the high-voltage input connector by pulling on the cable**  
Failure to comply with this rule may damage the cable, resulting in faults or fire.  
Hold by the high-voltage connector when unplugging.
- **Do not operate the instrument or insert or remove the AC plug or high-voltage input connector if you have wet hands**  
Failure to comply with this rule may result in electric shock or faults.
- **The twisted cable must be repaired**  
Don't use or keep cable when it is twisted. There is possibility that cable is disconnected internally.

### 10-1. Connection to The Simulator Main Unit

---

Fit the projection of the high voltage output connector of the tester to the groove of the high voltage input connector of the discharge gun and join them. Fix the joint by rotating the set screw of the high voltage input connector of the discharge gun clockwise.

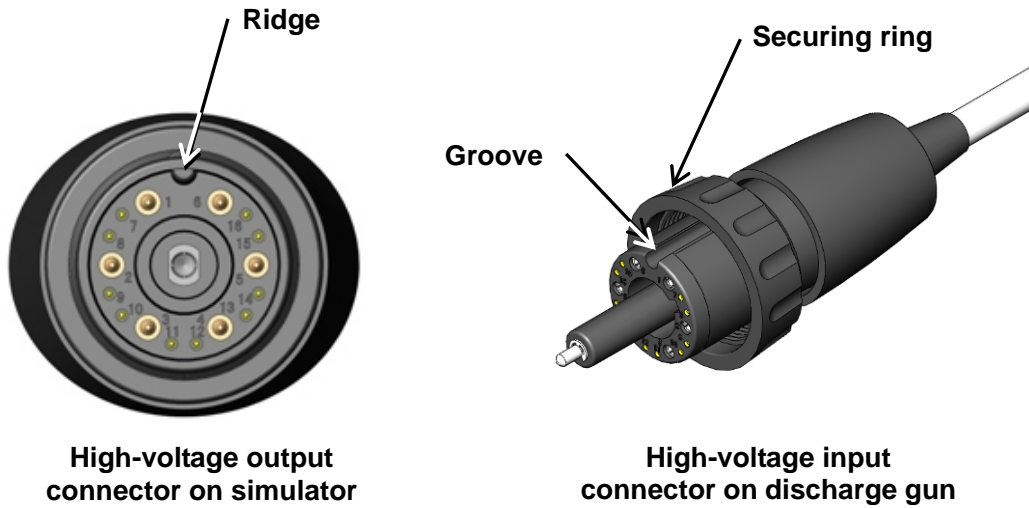

**Figure 10.1 High-voltage Connector**

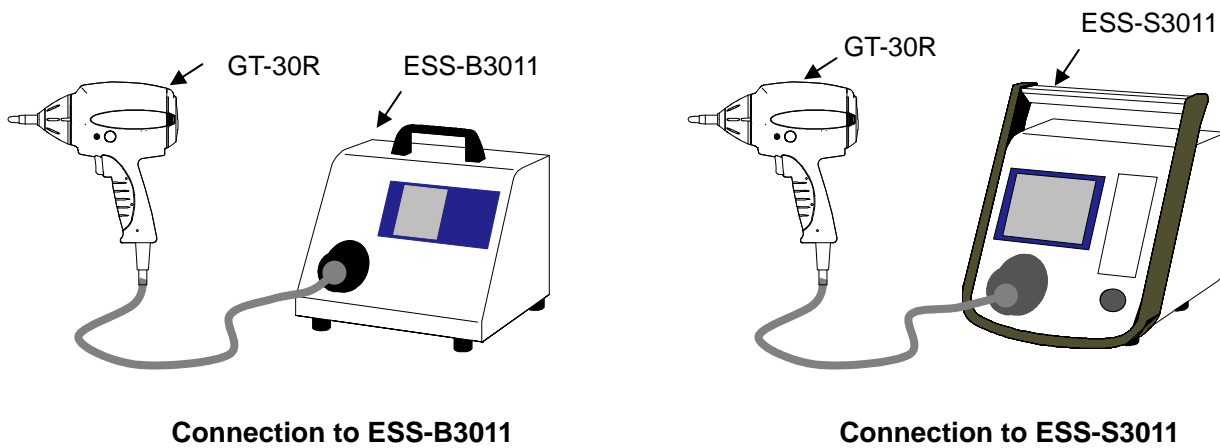

**Figure 10.2 Connection to Main Unit**



This product can also be connected to NoiseKen's previous simulator models such as ESS-2000AX.

For details, see **5-2. Combinations with Simulators.**

---

# 11. HOW TO REPLACE COMPONENT UNITS

## 11-1. Discharge Cup

### **WARNING**

- **When demounting or mounting the discharge cup, turn off the electrostatic discharge simulator or make it 【STOP】 status.**

Failure to follow this instruction might cause an electric shock or an injury.

### **CAUTION**

- **Use the discharge cup with the correct CR unit.**

Wrong combination of the discharge cup and CR unit can cause difference of the test result.

## Combination of Discharge Cup and CR Unit

By replacing the discharge cup and CR unit, this product allows the single discharge gun to output the output current waveforms that support two types of test standards (IEC 61000-4-2 and ISO 10605).

The combinations of the discharge cup and CR unit and their compliance test standards are as follows.

**Table 11.1 Combinations of Discharge Cup and CR Unit**

Discharge Cup	CR Unit	Compliance Test Standard
Discharge cup for 330Ω test	▪ 150pF-330Ω	IEC 61000-4-2
	▪ 150pF-330Ω ▪ 330pF-330Ω	ISO 10605 (330Ω test)
Discharge cup for 2kΩ test	▪ 150pF-2kΩ ▪ 330pF-2kΩ	ISO 10605 (2kΩ test)



The discharge cups and CR units other than those supplied with the product are optionally available (i.e. sold separately). The supplied accessories differ depending on the model. For details, refer to “2.CHECK PACKAGE CONTENTS” (P2-P4)

## Replacing Discharge Cup

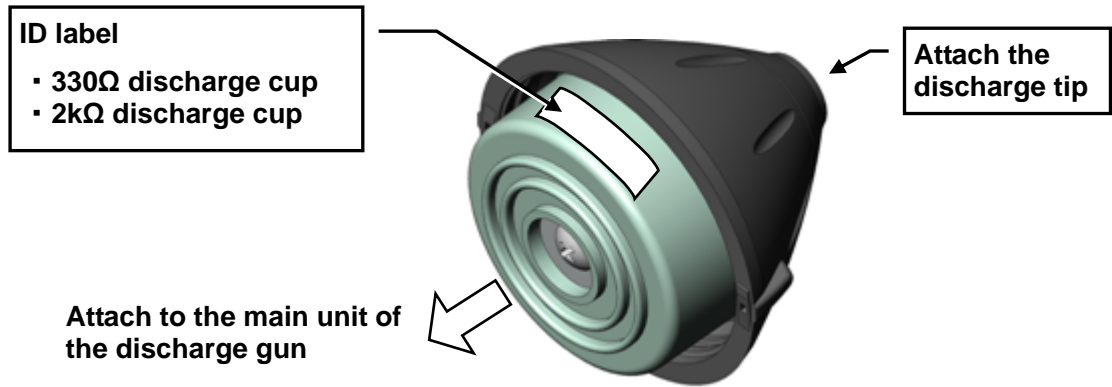

**Figure 11.1 Appearance of Discharge Cup**

To remove the discharge cup, turn it slowly anticlockwise while holding it firmly by hand. To attach it, turn it clockwise facing the main unit of the gun, until it locks, making a click sound.

In this case, align the side rib to the horizontal position.



Disassembly Prohibited

Do not disassemble the discharge cup. If you loose the screw of the discharge cup or remove the cover excessively, you may damage it.

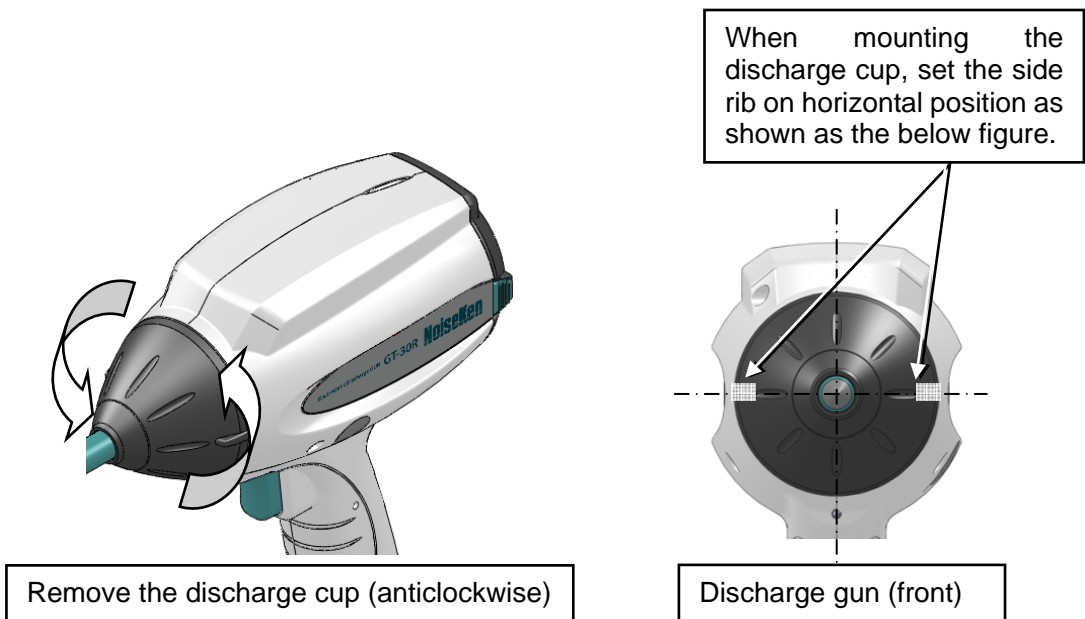

**Figure 11.2 How to Attach/Remove Discharge Cup**



The discharge cup is fixed with two-step locking structure. This locking structure may sometimes be tight soon after starting using. When mounting the discharge cup, confirm that the discharge cup is fixed completely with checking the position of the side rib. Since the gun may not perform well if the discharge cup is not on the right position, be sure to make it on right position.

## 11-2. Discharge Tip



**⚠ WARNING**

- **Before replacing the discharge tip, set the simulator to the stop state [STOP]**  
Failure to comply with this rule may result in electric shock or injury.
- **Before touching the discharge tip, remove static charge**  
After an electrostatic test, the discharge tip may still be charged at a high voltage. When replacing the discharge tip, remove any static charge (by making the discharge tip contact the GND clip, etc.) before touching the discharge tip.

## Types of Discharge Tips and Their Applications

There are three types of discharge tips, which are available as default, as shown in the following table. They must be used differently, according to the applicable test standard and test method.

**Table 11.2 Types of Discharge Tips and Their Applications**

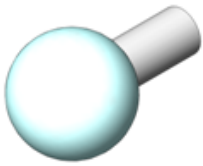
Type/Application	Shape	Compliance Standard
<b>Conical discharge tip</b> For contact discharge test		<ul style="list-style-type: none"> <li>● IEC 61000-4-2 Ed1.2 &amp; Ed2.0</li> <li>● ISO 10605 1st &amp; 2nd Ed.</li> </ul>
<b>Round discharge tip</b> For air discharge test		<ul style="list-style-type: none"> <li>● IEC 61000-4-2 Ed1.2 &amp; Ed2.0</li> <li>● ISO 10605 1st &amp; 2nd Ed.</li> </ul>
(*1) <b>Spherical discharge tip: <math>\Phi 30\text{mm}</math></b> For high voltage (over 15kV) air discharge		<ul style="list-style-type: none"> <li>● ISO 10605 2nd Ed.</li> </ul>

(\*1) The spherical discharge tip is only supplied with the ISO 10605 test set.



The air discharge tip for high voltages is used for tests under ISO 10605 2nd Edition.

It must be noted that the air discharge tip for high voltages is not allowed to be used under IEC 61000-4-2.

The round discharge tip tends to be unable to maintain a high voltage in an air discharge test exceeding 15kV, due to natural discharging into the air.

To improve this, use the spherical discharge tip instead.

## Replacing Discharge Tip

- 1) After removing static charge from the discharge tip, remove the tip by turning it anticlockwise while holding the discharge cup so that the cup does not become loose.
- 2) Turn the desired discharge tip clockwise to attach it to the discharge gun firmly.

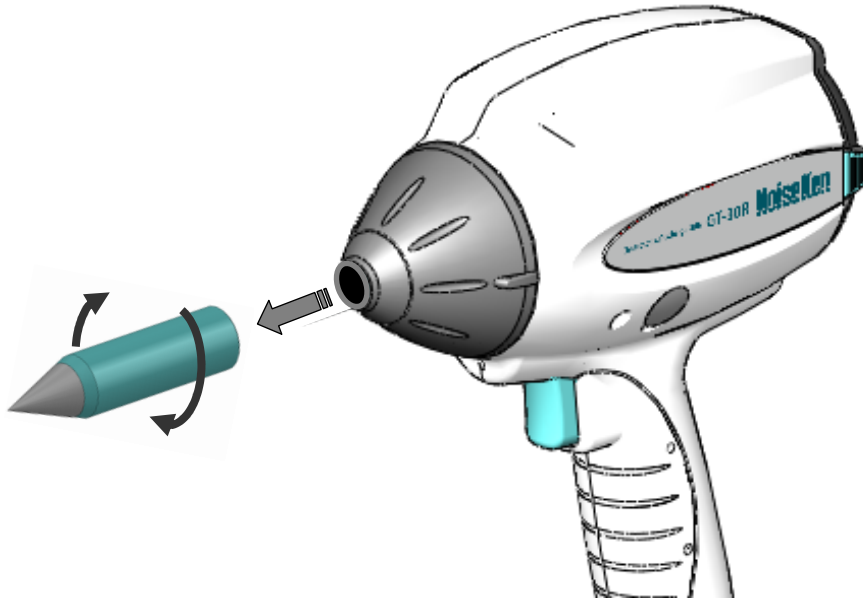

**Figure 11.3 Replacing Discharge Tip**

## 11-3. CR Unit

**⚠ WARNING**

- **Before replacing the CR unit, set the simulator to the [STOP] state**  
Failure to comply with this rule may cause an electric shock, an injury, or malfunction.
- **Before removing the CR unit, remove static charge**  
After an electrostatic test, the CR unit may still be charged at a high voltage.  
Before removing the CR unit, remove any static charge (by making the electrode of the high-voltage input connector contact the GND clip, etc.).

## Replacing CR Unit

- 1) Pull out the CR unit while pressing the lock buttons located on both sides of the CR unit.
- 2) Insert the desired CR unit and push it in firmly.

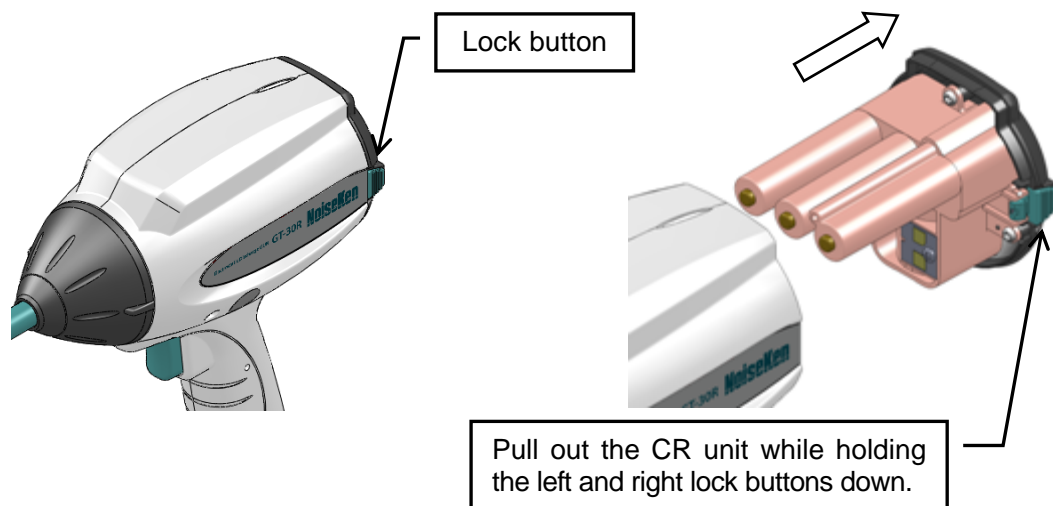
**Figure 11.4 Relacing CR Unit**

- **Insert the CR unit firmly, until the lock buttons make a click sound.**
- **Do not disassemble the CR unit.**  
Parts such as the energy storage capacitor and discharge resistor cannot be replaced.

### 11-4. GND Clip

---

The alligator clip at the end of the GND cable can be detached.  
When grounding the GND cable with a screw, remove the clip as shown below.

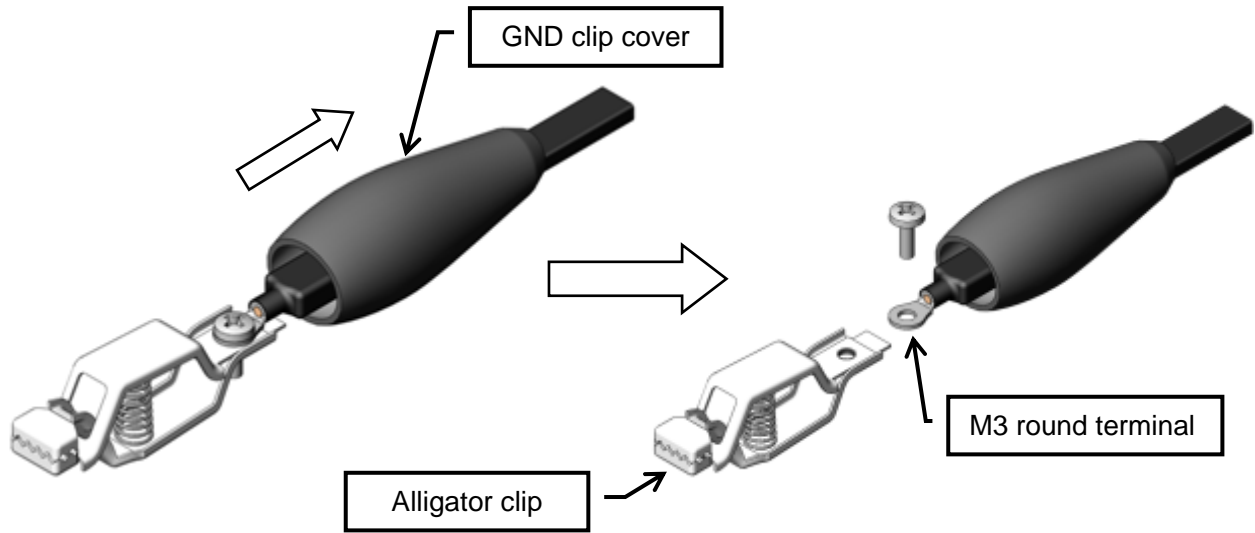

**Figure 11.5 How to Detach GND Clip**



## 12. OPERATION

This Operation Manual deals with the operation of Discharge Gun alone.

For operating procedures for the entire testing system, refer to the operation manual for the test system to be used in combination.

### 12-1. Starting Test

#### **⚠ WARNING**

- **Sufficient care must be taken during the test, as the voltage set in the simulator is generated.**  
Do not touch the discharge tip and discharge cup, as they are charged at a high voltage. Failure to comply with this rule may result in electric shock or injury.
- **Take care to ensure there are no other people close to the electrostatic testing environment, and that all necessary preparation for the test has been carried out.**  
Failure to comply with this rule may result in electric shock or injury.

#### **⚠ CAUTION**

- **The twisted cable must be repaired.**  
Don't use or keep cable when it is twisted. There is possibility that cable is disconnected internally.

- 1) When the simulator is started [START], a high voltage is output from the high-voltage output connector of the simulator and the status display lamp on the discharge gun is turned on in red.
- 2) Execute a test by operating the trigger switch.
- 3) If the discharge detection function is turned on, the status display lamp changes from red to green, when a discharge is detected. The discharge detection function is valid only in air discharge mode.

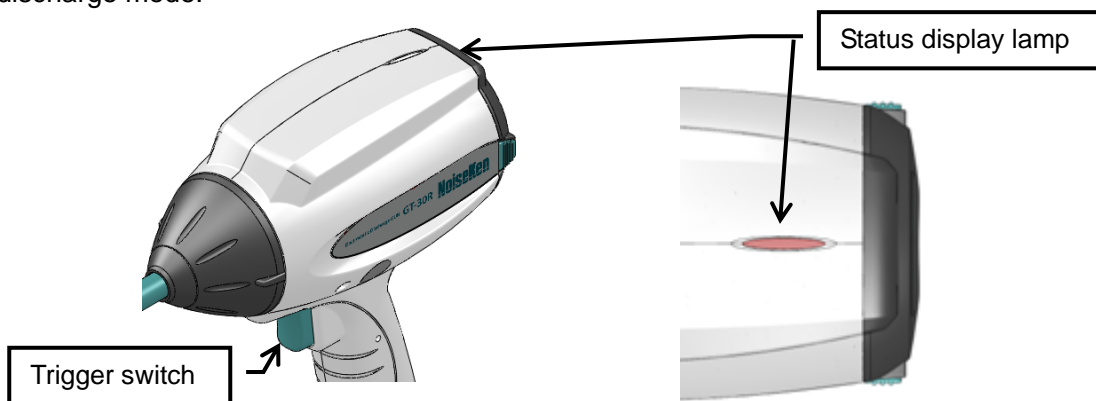

**Figure 12.1 Status Display Lamp**



If the status display lamp is not turned on by starting a test [START], check the following.

- Make sure that the high-voltage output connector of the simulator is connected to the high-voltage input connector of the discharge gun correctly.

If the display lamp remains turned off even after checking the above, the instruments may be faulty.

In this case, contact your sales agent or the Noise Laboratory.



The trigger switch of the discharge gun is enabled, when the trigger setting of the simulator's main unit is set to [GUN] .

---

## 12-2. LED Light

---

During the test, the light can be used for irradiation by enabling the LED light function [ON] .

When the main unit of the simulator is started, the LED light is turned on.

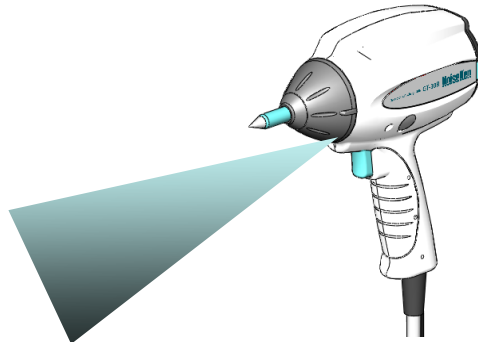

**Figure 12.2 LED Light**



With NoiseKen's previous simulator models such as ESS-2000AX, the LED light cannot be turned on.

---

## 12-3. Stopping a Test

---

### **⚠ WARNING**

- **Temporary stop by the trigger switch does not set the [STOP] state.**  
This is dangerous, because the unintentional trigger operation may restart the electrostatic discharge. Unless the test is to be resumed immediately, press the [STOP] switch on the simulator.  
Failure to comply with this rule may result in electric shock or injury.
- **Before touching the discharge tip, remove static charge**  
After an electrostatic test, the discharge tip may still be charged at a high voltage.  
When replacing the discharge tip, remove any static charge (by making the discharge tip contact the GND clip, etc.) before touching the discharge tip.

- 1) In the contact discharge mode, pressing the trigger switch again during discharging can stop discharge temporarily.  
In the air discharge mode, since electrostatic discharge cannot be discharged without pressing the trigger switch, this pause function by pressing the trigger switch is not available.
- 2) To stop the test, press the [STOP] switch on the simulator.

# 13. SPECIFICATIONS

## 13-1. List of Specifications

Parameters	Function/Performance													
Compliance standard	The compliance standard varies, depending on the discharge cup and CR unit.													
	<table border="1" style="width: 100%; border-collapse: collapse;"> <thead> <tr> <th style="text-align: center;">Discharge cup</th> <th style="text-align: center;">CR unit</th> <th style="text-align: center;">Compliance standard</th> </tr> </thead> <tbody> <tr> <td rowspan="2" style="text-align: center;">Discharge cup for 330Ω tests</td> <td style="text-align: center;">150pF-330Ω</td> <td style="text-align: center;">IEC 61000-4-2 Ed1.2 IEC 61000-4-2 Ed2.0 ISO 10605 2<sup>nd</sup> Ed</td> </tr> <tr> <td style="text-align: center;">330pF-330Ω</td> <td style="text-align: center;">ISO 10605 2<sup>nd</sup> Ed</td> </tr> <tr> <td rowspan="2" style="text-align: center;">Discharge cup for 2kΩ tests</td> <td style="text-align: center;">150pF-2kΩ</td> <td style="text-align: center;">ISO 10605 1<sup>st</sup> Ed ISO 10605 2<sup>nd</sup> Ed</td> </tr> <tr> <td style="text-align: center;">330pF-2kΩ</td> <td style="text-align: center;">ISO 10605 1<sup>st</sup> Ed ISO 10605 2<sup>nd</sup> Ed</td> </tr> </tbody> </table>	Discharge cup	CR unit	Compliance standard	Discharge cup for 330Ω tests	150pF-330Ω	IEC 61000-4-2 Ed1.2 IEC 61000-4-2 Ed2.0 ISO 10605 2 <sup>nd</sup> Ed	330pF-330Ω	ISO 10605 2 <sup>nd</sup> Ed	Discharge cup for 2kΩ tests	150pF-2kΩ	ISO 10605 1 <sup>st</sup> Ed ISO 10605 2 <sup>nd</sup> Ed	330pF-2kΩ	ISO 10605 1 <sup>st</sup> Ed ISO 10605 2 <sup>nd</sup> Ed
	Discharge cup	CR unit	Compliance standard											
	Discharge cup for 330Ω tests	150pF-330Ω	IEC 61000-4-2 Ed1.2 IEC 61000-4-2 Ed2.0 ISO 10605 2 <sup>nd</sup> Ed											
		330pF-330Ω	ISO 10605 2 <sup>nd</sup> Ed											
Discharge cup for 2kΩ tests	150pF-2kΩ	ISO 10605 1 <sup>st</sup> Ed ISO 10605 2 <sup>nd</sup> Ed												
	330pF-2kΩ	ISO 10605 1 <sup>st</sup> Ed ISO 10605 2 <sup>nd</sup> Ed												
Output polarity	Positive or negative													
Output voltage	0.20kV to 30.5kV													
CR unit (Energy storage capacitor and discharge resistor)	<p>The CR unit of this product cannot be disassembled in order to maintain its performance and prevent its misuse. To check and maintain the performance level, use a calibration service provided at the Noise Laboratory repair and calibration center on a regular basis.</p> <ul style="list-style-type: none"> <li>▪ 150pF±10%, 330Ω±10%</li> <li>▪ 330pF±10%, 330Ω±10%</li> <li>▪ 150pF±10%, 2000Ω±10%</li> <li>▪ 330pF±10%, 2000Ω±10%</li> </ul>													
Charging resistor	Contained in the CR unit													
Discharge current parameters (Contact discharge)	<p>See the following sections.</p> <p><b><u>13-2. Discharge Parameters and Waveform (150pF-330Ω, 330pF-330Ω)</u></b></p> <p><b><u>13-3. Discharge Parameters and Waveform (150pF-2000Ω, 330pF-2000Ω)</u></b></p>													
Charged voltage hold time	5 seconds or more													
Status display lamp	Red/Green													
Recommendable ESD simulator	ESS-S3011, ESS-B3011, ESS-2000AX													

Operating temperature range	+15°C to +35°C
Operating humidity range	20%RH to 60%RH (no condensation)
Storage temperature range	-10°C to +50°C
Storage humidity range	0%RH to 85%RH (no condensation)
Dimensions	(W)83.4mm × (H)217.2mm × (D)189.3mm (Without the discharge tip) Cable: 2m (approx.)
Weight	1.3kg (approx.)

13-2. Discharge Parameters and Waveform (150pF-330Ω, 330pF-330Ω)

Setup voltage [kV]	Peak current [A] ±10%	Rise time [ns]	Current value I <sub>1</sub> [A] ±30% (150pF: at 30ns) (330pF: at 65ns)	Current value I <sub>2</sub> [A] ±30% (150pF: at 60ns) (330pF: at 130ns)
2	7.5	0.7 to 1.0	4.0	2.0
4	15.0	0.7 to 1.0	8.0	4.0
6	22.5	0.7 to 1.0	12.0	6.0
8	30.0	0.7 to 1.0	16.0	8.0
15	56.25	0.7 to 1.0	30.0	15.0

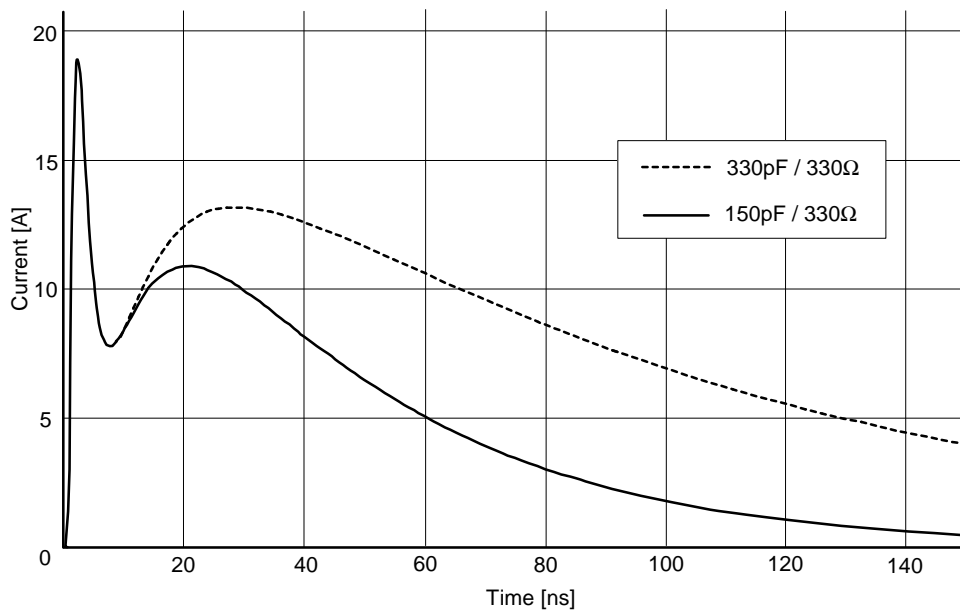

**Figure 13.1 330Ω Discharge Waveform (For reference)**



The table shows the parameters designed for ISO 10605 2<sup>nd</sup> Edition.  
For IEC 61000-4-2, the rise time is 0.8ns±25%.

## 13-3. Discharge Parameters and Waveform (150pF-2000Ω, 330pF-2000Ω)

Setup voltage [kV]	Peak current [A] -0%, +30%	Rise time [ns]	Current value $I_1$ [A] $\pm 30\%$ (150pF: at 180ns) (330pF: at 400ns)	Current value $I_2$ [A] $\pm 30\%$ (150pF: at 360ns) (330pF: at 800ns)
2	7.5	0.7 to 1.0	0.55	0.30
4	15.0	0.7 to 1.0	1.10	0.60
6	22.5	0.7 to 1.0	1.65	0.90
8	30.0	0.7 to 1.0	2.20	1.20
15	56.25	0.7 to 1.0	4.125	2.25

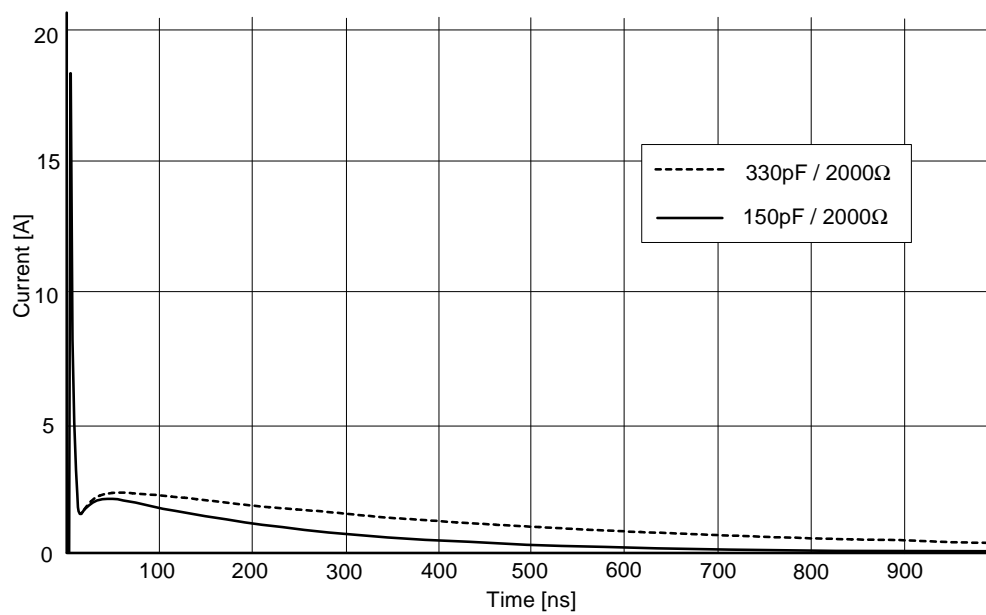
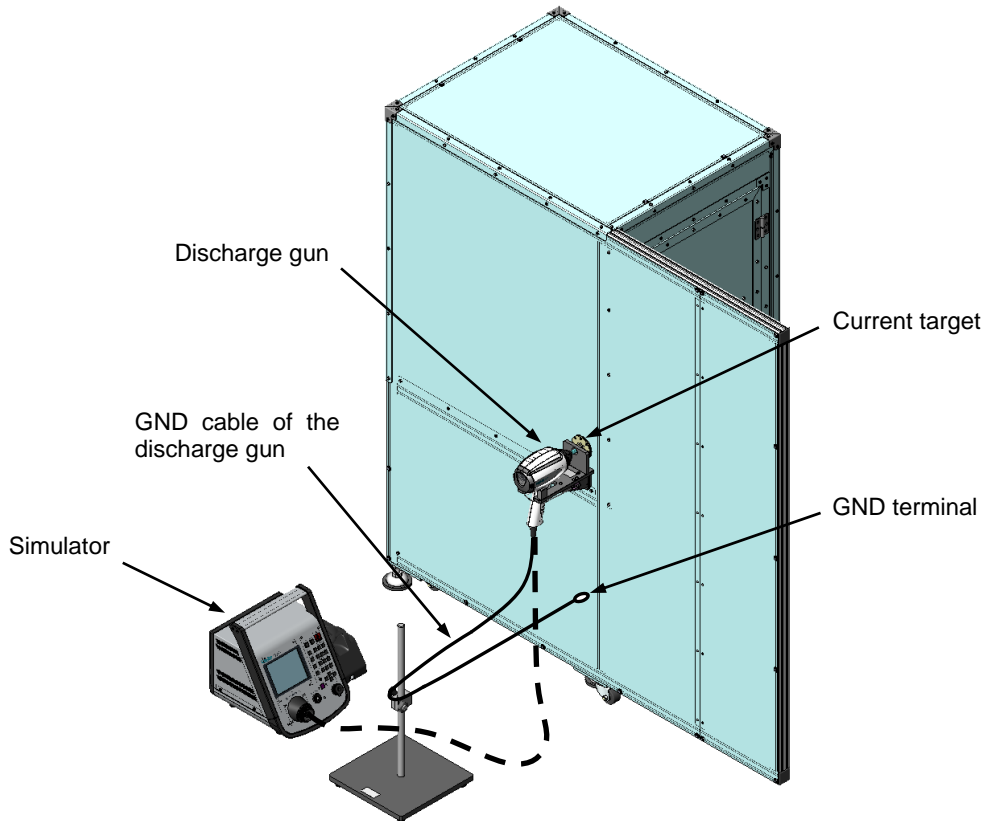

**Figure 13.2 2000Ω Discharge Waveform (For reference)**

# 14. CHECKING WAVEFORM

## 14-1. Equipment and Configuration

For observing the output waveform of this product, equipment shown in Figure 14.1 below, such as the Faraday cage, target, and oscilloscope (the frequency range: 2GHz or more for IEC 61000-4-2, and 1GHz or more for ISO 10605) is required



**Figure 14.1 Example of Equipment for Checking Waveform and Its Layout**

## 14-2. Accessories for Observing Waveform

Items	Model No.
Faraday cage <sup>*12-1</sup>	FC-200
Target mounting plate <sup>*12-1</sup>	03-00052B
Target mounting plate (for simplified measurement) <sup>*12-1</sup>	03-00027A
Load resistor (Target)	06-00067A
Attenuator (6dB SMA type)	00-00010A
Attenuator (20dB N type)	00-00011A
Coaxial cable(N-SMA 0.5m)	02-00132A
Conversion connector (SMA⇒BNC)	02-00133A
GND cable stand	03-00060A
Discharge gun holder	03-00061B

<sup>\*12-1</sup> Select one of FC-200, 03-00052B or 03-00027A.

## 15. RELATED ACCESSORIES

330Ω discharge cup: **03-00071A**  
For IEC 61000-4-2 and ISO 10605 330Ω tests



2kΩ discharge cup: **03-00072A**  
For ISO 10605 2kΩ tests



CR unit 150pF-330Ω: **06-00073B**  
For IEC 61000-4-2 and ISO 10605 330Ω tests

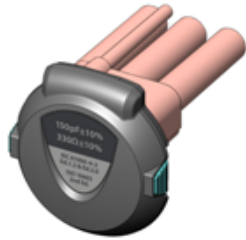

CR unit 330pF-330Ω: **06-00075B**  
For ISO 10605 330Ω tests

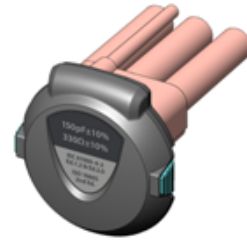

CR unit 150pF-2kΩ: **06-00074B**  
For ISO 10605 2kΩ tests



CR unit 330pF-2kΩ: **06-00076B**  
For ISO 10605 2kΩ tests

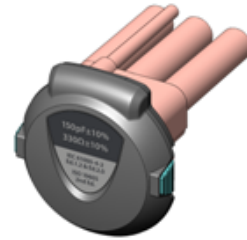

Contact discharge tip  
(Conical): **12-00007A**



Air discharge tip (Round):  
**12-00008A**

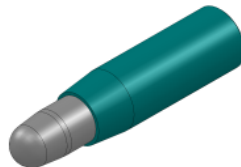

High voltage air discharge  
tip (SphereΦ30mm):  
**12-00009A**

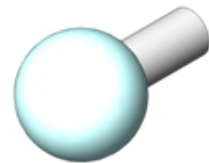

Storage case: **09-00006A**

It can store one discharge gun, two discharge cups, four CR units and one discharge tip each.

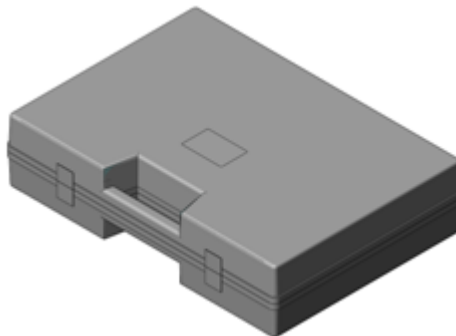

For details, please contact your nearest sales agent.

## 16. CALIBRATION

Both of the ESD immunity tests conforming to the IEC standard and the ISO standard are available on this unit with changing the gun head and/or the CR unit of the discharge gun. In case of calibrating this unit, specify the combination of 1) the main body of the discharge gun 2) the gun head 3) the CR unit.

Please provide the serial number of each unit in requesting calibration – The location of serial number is shown as the figure 16.1 as below.

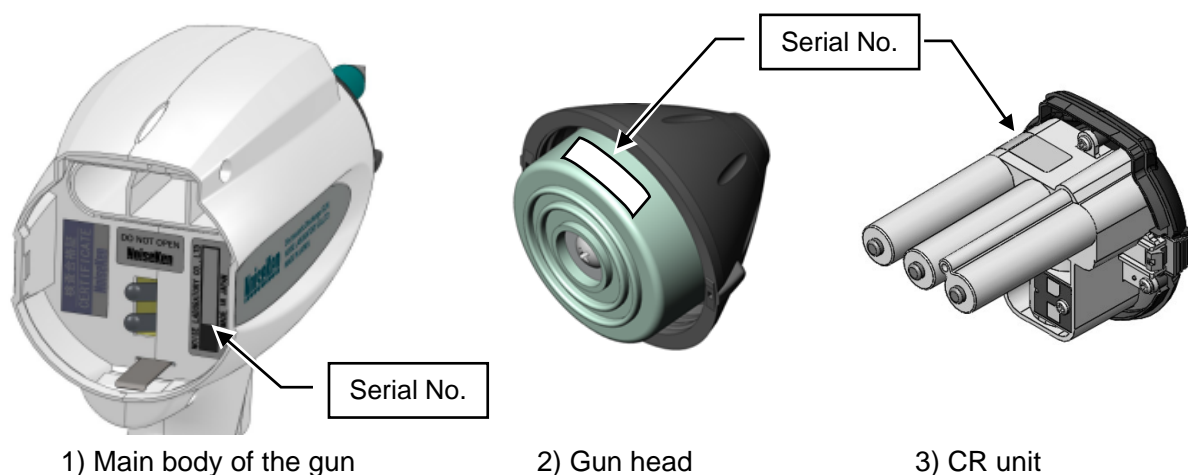

**Figure 16.1 Location of the serial number of each unit**

And, besides, this discharge gun is inspected and certified with the main unit of the electrostatic discharge simulator.

For requesting calibration, the serial number of the main unit should be notified with the above three numbers.

The serial number of the main unit is located on the rear panel. For details, refer to the instruction manual of the main unit.



# 17. WARRANTY

## Servicing terms

The following terms are applicable to servicing by Noise Laboratory Co., Ltd., (hereafter referred to as the Company) provided to maintain the intended performance of its products.

1. **Scope**  
The following terms shall apply only to products made by the Company.
2. **Technical servicing fee**  
In the event of a failure of a product within the warranty period (see warranty section), the Company will repair a product without charge. After the warranty expires, repairs will be billed at a nominal cost.
3. **Ownership of replacement parts**  
Any faulty parts replaced in the course of repair services shall belong to the Company. In the case when repairs are billed to the customer, replaced faulty parts will be retained by the Company unless other arrangements are made.
4. **Limited liability**  
In the event that damages resulting from servicing by the Company are intentional or caused by negligence, the Company will pay the cost but at the purchase value of the relevant product maximum. But, notwithstanding the foregoing, the Company shall not be responsible for any incidental or consequential damages of any nature, including without limitation thereof loss of would-be profit or compensation demanded from a third party.
5. **Incorrect parts, missing parts, and damage**  
In the event that the Company's product purchased by the customer has incorrect parts, missing parts, or is damaged, such that the product is not able to be used, the Company accepts no liability for any losses incurred by the customer that relate to lost earnings, commercial losses, other secondary losses, special losses, or indirect or punitive losses. Nor is any liability accepted for any losses resulting from a responsibility of the customer to compensate any third party.
6. **Refusal to provide repair services**  
The company may not accept a repair order in the following cases:
  - More than 5 years have passed since the product discontinued
  - More than 8 years have passed after delivery
  - Required component for servicing already discontinued and no alternative is available.
  - Product changed, repaired or remodeled without obtaining a prior permission from the Company.
  - Product severely damaged to the extent it has lost its original form

## Limited Warranty

Noise Laboratory Co., Ltd. (hereafter referred to as the Company) warrants its products to be free from defects in materials and workmanship under normal use and service for a period of one year from date of delivery. In the event of failure of a product covered by this warranty, the Company will repair the product or may, at its option, replace it in lieu of repair without charge.

Notwithstanding the foregoing, the Company shall not be responsible for any incidental or consequential damages of any nature, including without limitation thereof loss of would-be profit or compensation demanded from a third party. This warranty is valid only in Japan.

1. Scope

This warranty shall only apply to products made by the Company.

2. Period

One year from date of delivery.

The warranty may be valid in 6 months after servicing if the same failure on the same component has repeated.

3. Exclusions

The followings are exclusions from this warranty:

- ✧ Consumable parts (including mercury relay, HV relay, coaxial cable, coaxial connector, automatic switch, and contactor)
- ✧ Failure caused by misuse, neglect, accident or abnormal conditions of operation
- ✧ Failure caused by remodeling on the user side without prior permission from the Company
- ✧ Failure caused by servicing by unauthorized personnel by the Company
- ✧ Failure due to fore majeure including but not limited to, acts of God, fire, war, riot, rebellion and others
- ✧ Failure due to shock or drop in or after transit
- ✧ Failure due to operation in environment being out of ambient specifications.
- ✧ A unit shipped to overseas

## 18. MAINTENANCE

1. When repair, maintenance or internal adjustment of the unit is required, a qualified service engineer takes charge of such work.
2. Maintenance on the user side is restricted to the outside cleaning and functional check of the unit.
3. When checking or replacing the fuse, turn off the switch of the unit and disconnect the plug socket beforehand.
4. When cleaning the unit, turn off the switch of this unit and the connected equipment and disconnect the plug socket beforehand.
5. Avoid using chemicals for cleaning. Otherwise, the coating of the unit may peel off or the sight glass may be broken.
6. Do not open the cover of this unit.

## 19. CONTACTING TECHNICAL SUPPORT

- If you experience a malfunction, please have available both the model and serial number of your unit and contact the nearest distributor/agent or Noise Laboratory Technical Support.
- When it is necessary to send your unit back to Noise Laboratory, fill in the repair order form completely, pack the unit in the original package or equivalent one suitable for transit, and send the package.

Repair and Calibration Center

TEL +81-42-712-2051  
FAX +81-42-712-2050  
E-mail:sales@noiseken.com



---

**NOISE LABORATORY CO., LTD.**

Produced by: Noise Laboratory Co., Ltd.

1-4-4, Chiyoda, Chuo-ku, Sagami-hara City, Kanagawa Pref., 252-0237, Japan

TEL: +81-(0)42-712-2031 FAX: +81-(0)42-712-2030

URL: <http://www.noiseken.co.jp>

Printed in Japan