

Impulse Noise Simulator

INS-S220 / S420

IJ-AT450 (Automatic CDN for Impulse Noise Simulator)

NEW
4kV type

Mercury
free



Make EMC Test Easier !

www.noiseken.com



Impulse Noise Simulator (semi-conductor type)
INS-S220 / S420

To solve the real trouble in the market

This Noise simulator simulates high frequency noises generated by ON/OFF switching at contact points of switches or relays, and arcs caused by electric motor, allowing to evaluate the resistibility of electric devices.

The Pulse contains wide range of frequency components and energy volume is changeable by adjusting pulse width. This allows conducting of highly-reproducible noise tests for noise troubles in the market.

- Button touch instead of coaxial cable replacing reduces pulse width setting time.
- Pulse waveform stability has improved, allowing highly-reproducible testing.
- Consumable parts reduction cut down running cost.
- Common mode/normal modes are easily switched between by a short plug.
- "Test time setting" new function simplifies test time setting.
- Wiring became easier thanks to a built-in 50Ω terminator resistor design.
- Repetition cycle became faster. Due to high repetition, malfunction occurrence rate is up and test time is shortened.(only INS-S220)
- Outlet Panel allows direct connection of EUT AC plug.(option)
- Various tests are available by using different probes and coupling clamps.(option)
- Using of external CDN allows testing to 3-phase EUTs.(option)
- Dedicated software simplifies testing with various test conditions (option, applicable to INS-S420 only)



Features

To solve the trouble in the market Test pulse with adjustable high frequencies and energy volume

Narrow pulse of 50-100ns width although contains small energy, greatly affects electric circuits due to two transient fluctuations of short-time rise and fall and inductive coupling by steeply generated electromagnetic field.

Wide pulse of 800ns-1000ns contains more energy, making it easy to apply large voltage fluctuations to the circuit.

The rise time of impulse simulator is faster than IEC61000-4-4 fast transient/burst test and contains high frequency components up to 1GHz.

Therefore, when noise is applied to the EUT, it is easier to penetrate and affect the electronic circuit.

In addition, since the included frequency spectrum components and intensity differ depending on the pulse width of the impulse, it is recommended to conduct tests with several types of pulse widths.

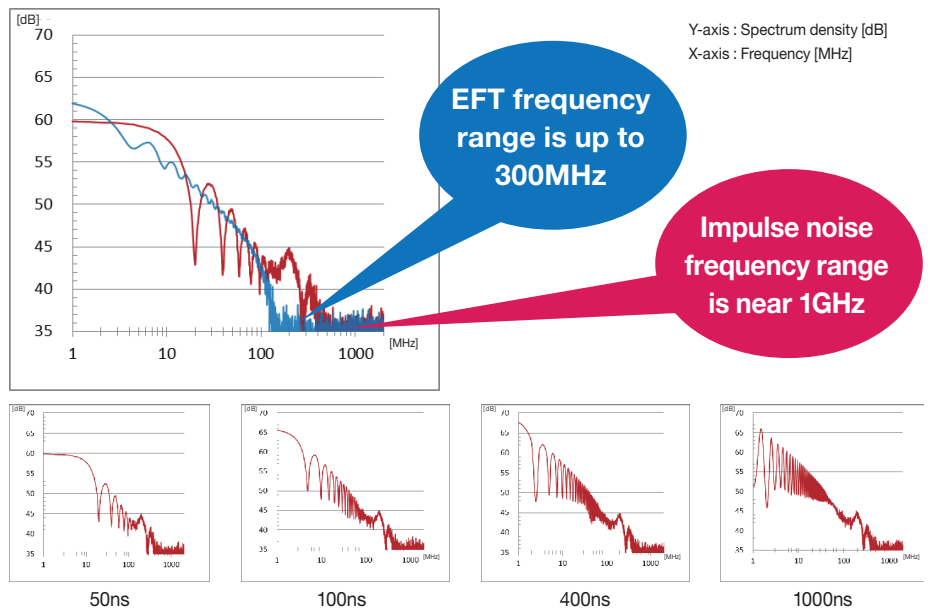
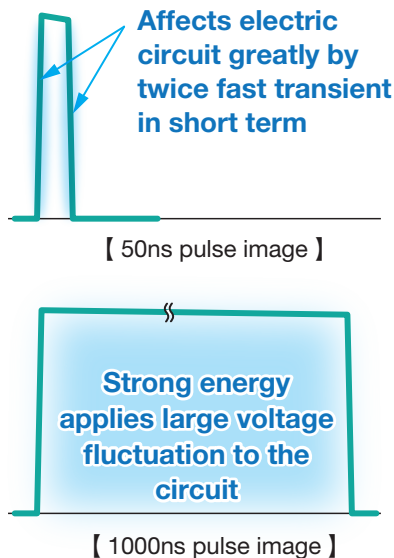

INS-S220 / S420

Improved reproducibility of test results Allows for more quantitative testing

By changing from the conventional mercury relay to the semiconductor relay, the stability of the test pulse waveform has been improved, enabling tests with more quantitative and highly reproducible test results than before. In addition, the output waveform defect occurring with the mercury relay deterioration has been eliminated.

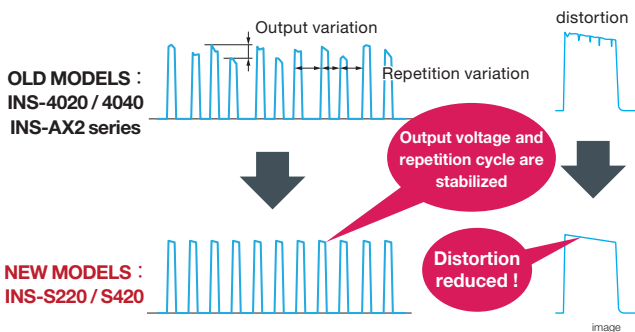

Improved malfunction occurrence rate Contributes to testing time reduction

By speeding up the test pulse repetition period compared to old models, product malfunction occurrence rate should increase contributing to overall test time reduction.

Example : In case the repetition cycle is 2ms

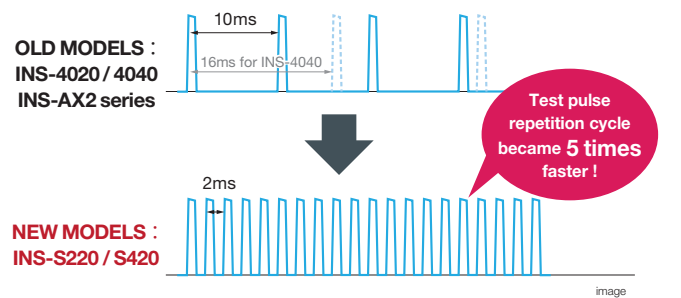

* There are restrictions on the pulse repetition period.

Pulse Width setting simplified Setting time reduced

Pulse width setting in old models (INS-4020/4040) required troublesome manual cable connection switching. New Impulse Noise Simulator models INS-S220/S420 setting is simple by pushing buttons, reducing setting time and helping avoid connection errors.



Complicate cable connection setting becomes...

SIMPLE with button operations.

Connection simplified Connection time reduced

Outlet panel was adopted for easy EUT connection. By using an outlet panel (optional) matching the shape of each country, you can easily connect EUT for the test.



Operating Cost reduction Consumable parts reduced

Adopted semiconductor type relay instead of old mercury type relay (consumable).

Consumables such as pulse width setting cables and mercury relays are no longer required, reducing replacement costs.

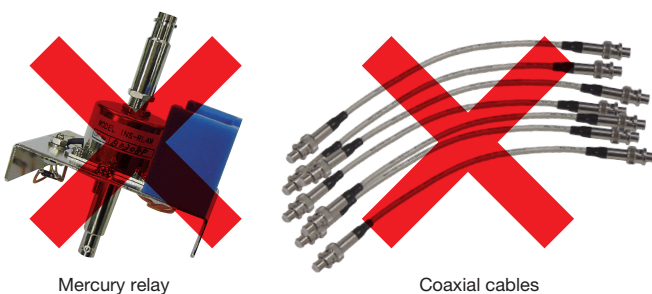

Mercury relay

Coaxial cables

Easy Noise countermeasurement Identify the malfunction location

A large number of noise application options are available for power lines, communication lines, harnesses, housings, and board levels, making it easy to identify malfunction locations.



INS-S220 / S420

Specifications

Parameter		INS-S220	INS-S420
Pulse settings-1	Pulse output voltage	0.50kV ~ 0.99kV ±10% 0.01kV step	-
	Pulse width	100ns ~ 1000ns ±10% 50ns step	
	Repetition cycle	1ms ~ 999 ms ±10% 1ms step	
Pulse settings-2	Pulse output voltage	1.00kV ~ 2.00 kV ±10% 0.01kV step	0.50kV ~ 4.00kV ±10% 0.01kV step
	Pulse width	50ns ~ 1000 ns ±10% 50ns step	50ns ±15%、100ns ~ 1000ns ±10% 50ns step
	Repetition cycle	10ms ~ 999 ms ±10% 1ms step	
Output voltage		0.5 ~ 2.00kV ± 10% (10V step)	0.5 ~ 4.00kV ± 10% (10V step)
Polarity		+ / -	
Rise time		<3ns	
Output impedance		50Ω	
Terminal resistance		50Ω	
Pulse repetition modes	LINE PHASE	50Hz/60Hz injection phase angle 0 ~ 360° ±10° (1° step) synchronized with L-N of EUT supply or external CDN	
	VARIABLE	1ms ~ 999ms ± 10 % (~ 1kV) *pulse settings-1 10ms ~ 999ms ± 10 % (1kV ~ 2kV) *pulse settings-2	10ms ~ 999ms ± 10 %
	EXT TRIG	Period : >10ms Input signal level : TTL/open collector negative logic Pulse width : >1ms When LINE PHASE mode is selected and there is an input with a period of 16 to 20 ms, it is recognized as a zero-cross sync signal for external CDN.	
	1 SHOT	Single pulse generation each time the 1 SHOT button is pressed. Synchronized (phase angle set on the PHASE control) or asynchronized pulse period.	
Memory storage		5 tests	
Test time		1s ~ 999s ± 10% 1s step	
Coupling switch		L(+), N(-), PE / PULSE OUT *manual switch by coaxial cable	
Coupling mode		common-mode / normal-mode *manual switch by short plug	
EUT power capacity		Single phase AC240V / DC125V 16A (L(+), N(-), PE)	
External control		N/A	RS-232C compliant optical communication
Power supply		AC100 ~ 240V 50Hz/60Hz	
Operating temperature / humidity		15 ~ 35°C / 25 ~ 75%	
Dimensions / weight		(W) 430× (H) 249× (D) 540mm (protrusions excluded) / approx. 20kg	(W) 430× (H) 349× (D) 540mm (protrusions excluded) / approx. 23kg
HV coaxial cable connector		NMHV Noiseken custom type	
Accessories		coaxial cable 30cm (O2-00155A): 2pcs, SG short plug (O2-00106A): 1pc, SG cable (O5-00103A): 1pc, outlet panel: 1pc, AC cable: 1pc, Instruction Manual: 1 volume, accessories bag: 1pc	



Automatic CDN for Impulse Noise Simulator

IJ-AT450

Automatic CDN for Impulse Noise Simulator (Model:IJ-AT450) is a superposition unit allowing testing to 3-phase AC lines and high-voltage DC lines by combining with the Impulse Noise Simulator. By performing remote control from Windows PC using dedicated software, the tester can automatically perform the test such as setting of voltages and applied phase, as well as sequence control.

- Tests can be performed on three-phase four-wire lines up to AC500V/50A.
- Testing to DC-lines up to DC250V/50A is also possible.
- EUT line switch allows the AC/DC line to be shut off.
- Emergency stop switch to stop the test in case of emergency.



IJ-AT450 in connection with INS-S420

Parameter	Specifications
Input pulse voltage	4kV terminating resistance 50 Ω is connected
EUT power capacity	AC: 3-phase, 4-wire (L1, L2, L3, N) 500V / 50A DC:250V / 50A
Input and output terminals	Input terminal: Terminal block Output terminal: Terminal block panel
High voltage coaxial connector	NMHV type *NoiseKen custom
Superimposed phase switching	Switching by selection operation *Switching by the front switch of the main unit or remote software.
Zero Cross Detection	Detected from between L1-L2
Line protection circuit	Mounted with shut-off circuit device *Connectable/releasable input and output
Emergency stop	Built-in mushroom-type switch for push-lock and rotation-release
External control	Remote control from PC with optical I/F circuit
Power supply	AC100 ~ 240V 50Hz/60Hz
Operating temperature /humidity	Temperature: 15 to 35° Humidity: 25 to 75%
Dimensions/weight	(W)430×(H)199×(D)540mm (protrusions excluded) / Approx. 24kg
Accessories	BNC coaxial cable (02-00159A): 1pc, high-voltage coaxial cable (02-00160A): 1pc, AC cable: 1pc, SG cable (05-00172A): 1pc, outlet panel (18-00074A): 1pc, instruction manual: 1 volume, accessories bag: 1pc.

Easy switching of application phase Setting time reduced

In the old model, setting the applied phase was troublesome requiring manual switching using the dedicated coaxial cables and short-plug. IJ-AT450 simplifies switching and reduces setting time and helps avoid connection errors.

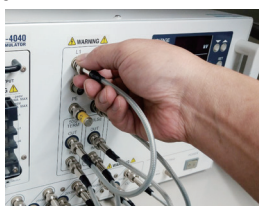

Applied phase switching with coaxial cables is troublesome..



Button operation makes it easy!!

Connection simplified Connection time reduced

Outlet panel was adopted for easier EUT connection and conducting the test.

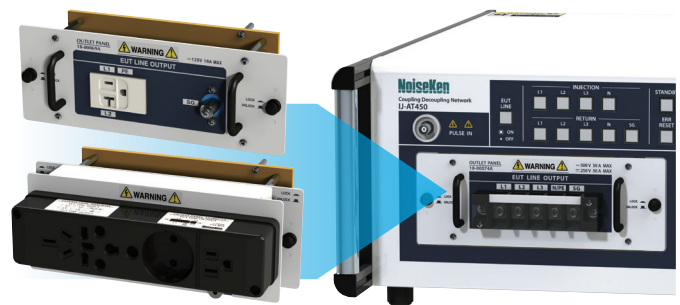

Remote control Testing automation reduces testing time and man-hours

Using remote control software, in addition to test parameters such as pulse output voltage, pulse width, polarity, and repetition period, the application mode (common/normal) and applied phase can be set, and the test conditions can be controlled in sequence. This reduces the time and effort required to change the wiring during testing and contributes to shortening the testing time and reducing the number of man-hours.

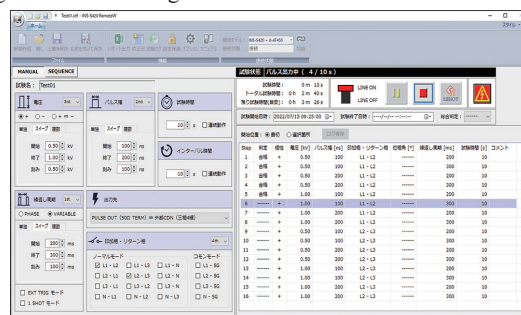
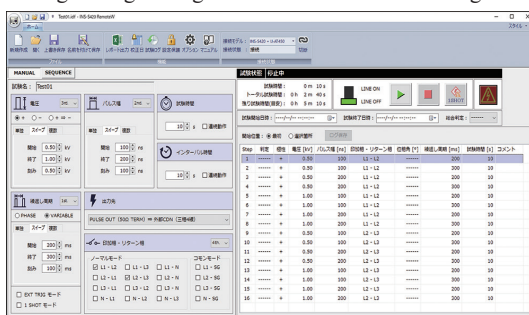

INS-S420 Remote Control Software

INS-S420 RemoteW Model:14-00062A

INS-S420 RemoteW (Model: 14-00062A) is a dedicated software for remote control of INS-S420 or INS-S420 & IJ-AT450. Using this software, you can set the application mode as well as test parameters such as pulse output voltage, pulse width, phase angle and repetition period. Test conditions can be controlled in sequences, which contributes to reducing the test time and man-hours.

- Manual tests can be performed by setting test parameters such as pulse output voltage, pulse width, phase angle, repetition period, and test time.
- Sequence tests can be performed by arbitrarily combining manual test data.
- Test information such as test conditions, test list, etc, can be generated into a Test Report and exported in Excel format.
- EUT FAIL signal detected using digital I/O.
- Compatible with Windows 10,11 64 bit versions with English and Japanese supported languages.
- Various settings data can be protected by the "Settings Protection" function.

Hardware Configuration

【PC Remote control of INS-S420】

Allows controlling the pulse output voltage, pulse width, phase angle and repetition period of the Simulator's main unit, however application phase and return phase switch control is not available.

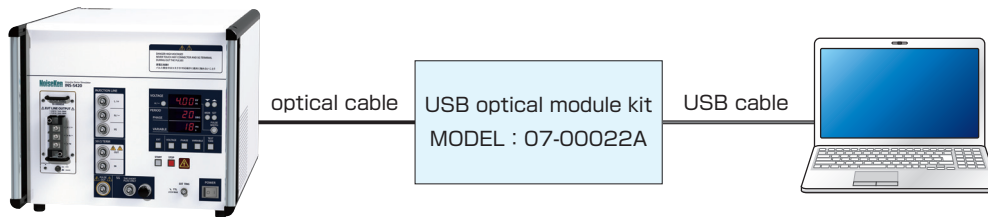

【PC Remote control of INS-S420 & IJ-AT450】

Allows controlling the pulse output voltage, pulse width, phase angle and repetition period of the Simulator's main unit, and also application phase and return phase switching and EUT LINE ON/OFF control is available.

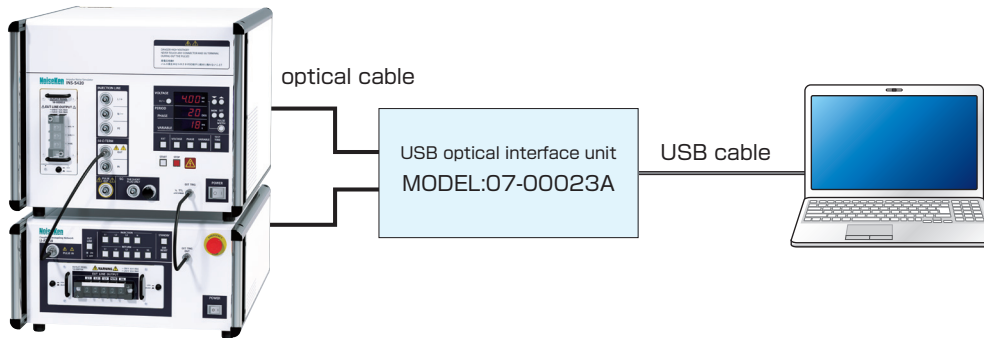

Software System Requirements

Parameter	Specifications
OS	Windows 10, 64bit (English or Japanese ver.) Windows 11, 64bit (English or Japanese ver.)
CPU	Dual-Core over 2.4GHz or better recommended
RAM	8GB or more recommended
Storage	5GB available free space
Display	1920×1080 pixels (FullHD) or more recommended

【Attention】

- Operation is not guaranteed when using software on cloud services or using online storages.
- For correct "Report Export" function, be sure to have installed Microsoft Excel compatible with the OS and within the support period. (Please use the Desktop version, not the Store App version.)
- Optical USB Interface unit is required (models 07-00022A or 07-00023A).
- Available USB ports required.
(2 USB ports required. In case of using Digital I/O - 3 USB ports required.)
- CD-ROM or DVD-ROM drive required for installing drivers for the Optical USB Interface.

Remote Control Software

Manual Test

Settings Screen

* Software English version available

Run Screen

The screenshot displays three main windows of the software. The 'Manual Test' window on the left shows test parameters like voltage (0.50 kV) and pulse width (100 ns). The 'Settings Screen' in the middle shows various control options. The 'Run Screen' on the right shows a test sequence table with columns for Step, Voltage, Pulse Width, and Duration. A red arrow labeled 'TEST RUN' points to the 'Run' button. On the Run Screen, there are status indicators for 'LINE SW ON' and 'WARNING lamp blinking'.

Step	Phase	Voltage [kV]	Pulse Width [ns]	Repetition Period [ms]	Test Time [s]	Comments
1	合相 +	0.50	100	L1-L2	200	10
2	合相 +	0.50	100	L1-L2	300	10
3	合相 +	0.50	200	L1-L2	300	10
4	合相 +	0.50	200	L1-L2	300	10
5	合相 +	1.00	100	L1-L2	300	10
6
7
8
9
10
11
12
13
14
15
16

Manual tests can be performed by setting test parameters such as pulse output voltage, pulse width, phase angle, repetition period, and test time.

Sequence Test

The screenshot shows the 'Sequence Test' window with a table of test steps. A red box highlights the 'Loading of Manual Test data' callout, which points to a table of test data being loaded into the sequence.

No.	Test Name	Phase
1	Test01	合相
2	Test02
3	Test03

Sequence tests can be performed by arbitrarily combining manual test data.

Report Generation

The screenshot shows the 'Report Generation' window. A red box highlights the 'Excel Export' callout, which points to the 'Excel' button. Another red box highlights the 'Test Report' callout, which points to the 'Test Report' button.

Test information such as test conditions, test list, etc. can be generated into a Test Report and exported in Excel format. Test Report can be set to a desired format by loading a template file.

Sweep Function

The screenshot shows the 'Sweep Function' window. A red box highlights the 'Priority Settings' callout, which points to the 'Priority' dropdown menu in the test parameters section.

Sweep test with priorities set for test parameters is available.

EUT FAIL signal detection function

The screenshot shows the 'EUT FAIL signal detection function' settings window. It contains two panels for configuring detection settings, including options for 'EUT FAIL 1' through 'EUT FAIL 8' and 'EUT FAIL 信号検出判定'.

By using a digital I/O by National Instruments, you can detect up to 8 EUT FAIL signals and you can set the operation and judgment when EUT FAIL signals are detected. Please contact us for more details.

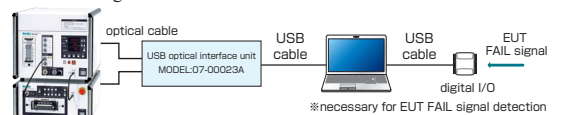

Options

Attenuator for waveform check **MODEL : 00-00017A**



Attenuator for measuring high voltage pulse.

Parameter	Specifications
Attenuation rate	DC~2GHz : 40dB (100 : 1)
Input pulse peak voltage	4000V MAX
Tolerable continuous pulse examples	Pulse width : 50ns~1000ns Pulse repetition frequency : Max. 60Hz at 4000V output; Max. 100Hz at 2000V 1 hour continuous use
Input impedance	50Ω (50Ω ± 1% at DC)
Output impedance	50Ω (50Ω ± 1% at DC) *If using an oscilloscope with high input impedance (1 MΩ), a 50Ω termination is required.
Interface connectors	INPUT : HN(F) OUTPUT : N(F)
Dimensions/ Weight	(W)154.5mm×(D)105mm×(H)37mm / Approx 1350g
Accessories	Input cable (HN(P)-NMHV(P) 0.5m) 1pc., Output cable (N(P)-BNC(P) 1m) 1pc., Instruction Manual 1pc.

Attenuator **MODEL : 00-00011A**



Attenuator for protecting measuring instruments.

It is recommend to use this attenuator when using the waveform checking attenuator (00-00017A) to protect measuring instrument.

Attenuating rate 20dB, N type connector INS-S220/S420 → coaxial cable → 00-00017A → 0000011A → coaxial cable → oscilloscope

PULSE DIVIDER for INS **MODEL : 00-00021A**



Voltage divider enabling low voltage test by dividing and outputting high voltage pulses at a ratio of 4:1.

Parameter	Specifications
Attenuation rate	DC~2GHz : 12dB (4 : 1)
Input pulse peak voltage	2000V MAX
Tolerable continuous pulse examples	Pulse width : 10ns~1000ns Pulse repetition frequency : 2000V output ≤ 62.5Hz (continuous output)
Input / Output impedance	50Ω (50Ω ± 1% at DC)
Interface connectors	HN(F)
Dimensions / Weight	(W)169mm×(D)119mm×(H)37mm / Approx 1490g
Accessories	I/O cables (HN(P)-NMHV(P) 0.5m) 2pcs., Output cable (HN(P)-HN(P) 0.3m) 1pc., Instruction Manual 1pc.

Outlet Panel **MODEL : 18-00059C/60B/84A**



Outlet panel to be available for different types of connectors in line output of INS-S220 / S420.

Model	Specifications
18-00059C	JP/USA Type AC125V 16A MAX
18-00060B	CEE Type AC240V 16A MAX
18-00084A	multi outlet type AC240V 16A MAX

Outlet Panel **MODEL : 18-00069A/71A**



Outlet panel for converting the line output connector IJ-AT450

Model	Specification
18-00069A	JP/USAType AC125V 16A MAX
18-00071A	multi outlet type

Coupling Adaptor **MODEL : 15-00014A**



Allows noise application combined with an Impulse Noise Simulator by simply inserting a cable of an electronic device. Calibration fixture (15-00015A) for this clamp is also available.

- Allows to injecting the noise without cutting signal, DC, AC, GND, etc.
- Allows to test noise immunity of electric devices separately.
- Allows highly-effective noise immunity testing since the noise can be injected directly to signal lines.

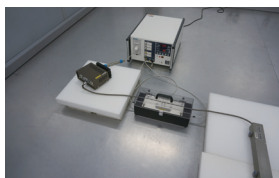

Parameter	Specifications
Input voltage	4000V Max
Input pulse width	50~1000ns
Coupling method	Capacitive coupling
Dimensions / Weight	(W)386×(H)155×(D)140mm (protrusions excluded) / Approx 4kg
Adequate cable dimensions	maximum diameter 20mm
Terminal resistor	N/A
Coaxial connectors	Coaxial cable NMHV(P)-NMHV(P)-1.5M 2pcs

Options

Coupling Adaptor **MODEL : CA-805B (Capacitive coupling)**



Allows noise application combined with an Impulse Noise Simulator by simply inserting a cable of an electronic device.

- Allows injecting the noise without cutting signal, DC, AC, GND, etc.
- Allows to test noise immunity of electric devices separately.
- Allows highly-effective noise immunity testing since the noise can be injected directly to signal lines.
- Allows to clamp bundle of lines whose of maximum diameter up to 26mm.

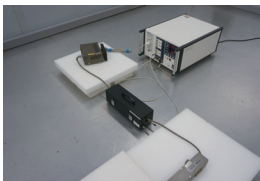

Parameter	Specifications
Input voltage	4000V MAX
Input pulse width	50~1000ns
Coupling method	Capacitive coupling
Dimensions / Weight	(W)350×(H)105×(D)110mm (protrusions excluded) / Approx 3kg
Adequate cable dimensions	maximum diameter 26mm
Terminal resistor	N/A
Coaxial connectors	Coaxial cable NMHV(P)-NMHV(P)-1.5M 2pcs (MODEL 02-00025A)

Coupling Adaptor **MODEL : 15-00007A (CA-806 / Magnetic field coupling)**



Allows noise application combined with an Impulse Noise Simulator by simply inserting a cable of an electronic device.

- Allows injecting the noise without cutting signal, DC, AC, GND, etc.
- Allows to test noise tolerance of electric devices separately.
- Termination resistance built-in.

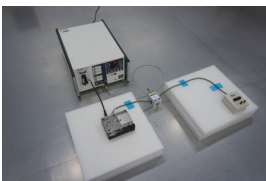

Parameter	Specifications
Structure	Magnetic field coupling noise injection clamp
Input voltage	2000V Max.
Input pulse width	50~1000ns
Coupling ratio	1/10±10% of input voltage
Termination resistance	50Ω built-in(54Ω)
Max. diameter of ground cable	27mm
Dimensions / Weight	(W)89×(H)64×(D)120mm / Approx 1000g
Coaxial connector	NMHV(P)-NMHV(P) 1m: 1pc. (MODEL: 02-00053A)

EMS Probe Kit **MODEL : H2-B**



Probes for noise injection onto PCB patterns and flat cables using the Impulse Noise Simulator. By choosing different probes, it is possible to separate the electric field/magnetic field and perform near field irradiation. * Max. pulse voltage: 1kV, max. pulse width: 50ns, fastest repetition period: 10 ms)

- Noise can be applied to any part of a PCB or harness.
- Allows to detect noise immunity weak points by separating and combining use of electric/magnetic field probes.
- A set of 3 electric field probes and 3 magnetic field probes with different shapes and sizes.
- Noise can be applied in the range of several millimeters, allowing to easily identify weak points.
- Allows to identify weak points for specific frequencies by using a signal generator as a wave source.
- Suited for locating noise sensitive spots by using with the INS or FNS equipment

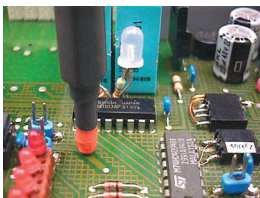

BS05DB

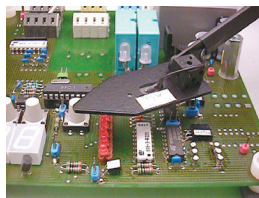

ES02

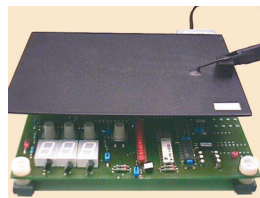

ES00

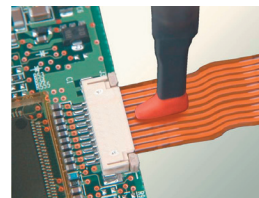

ES05D

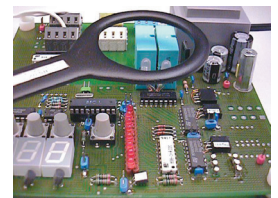

BS02

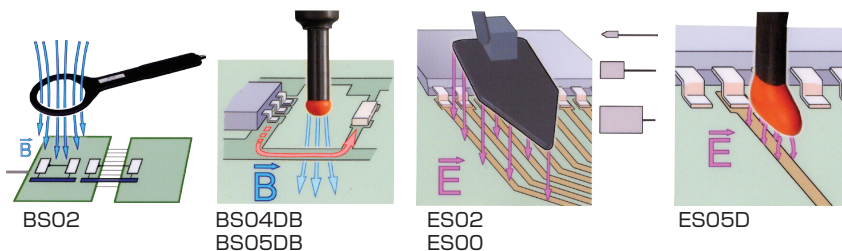

Options

Noise Injection Probe MODEL : 01-00034A



A probe for injecting noise directly into the pattern and parts of the printed circuit board.

*Input pulse repetition period: 10 ms or more

- Noise immunity can be tested at the board level because noise can be injected directly into each pin of the LSI.
- Up to 500V noise injection is possible utilizing INS or FNS simulator.
- Possible to exchange the coupling capacitor (Option)
- 50 ohm termination resistor built-in

[Options]

Coupling capacitors: 06-00039A 220pF. 06-00040A 330pF. 06-00041A 3pF. 06-00042A 500pF.

* 01-00034A does not include the coupling capacitors

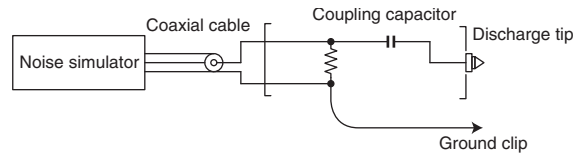

Radiation Probes MODEL : 01-00006A / 7A / 8A / 9A / 10A / 31A / 50A



These probes, in combination with Impulse Noise Simulator allows to emit electromagnetic field radiation noise to the wiring of PCB inside electronic equipment, and is used to search for areas vulnerable to radiation noise.

Parameter	Specifications
Input voltage	4000V Max
Input pulse width	50~1000ns (1μs)
Loop diameter	01-00006A : φ50mm, 01-00007A : φ75mm, 01-00008A : φ100mm, 01-00009A : φ150mm, 01-00010A : φ200mm, 01-00031A : 250mm, 01-00050A : 30mm
Cable length	Approx.2m
Weight	Approx.180g~220g
Termination Resistance	N/A

Probes application examples

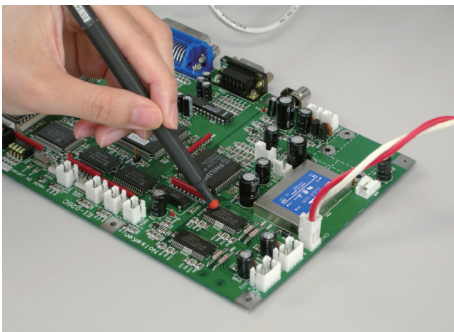

H2-B

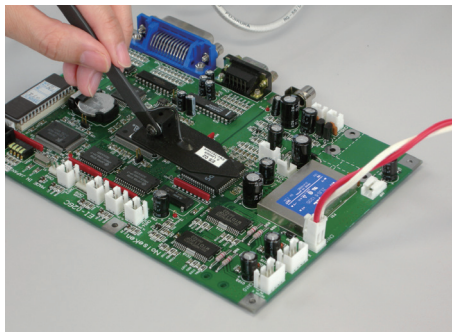

H2-B

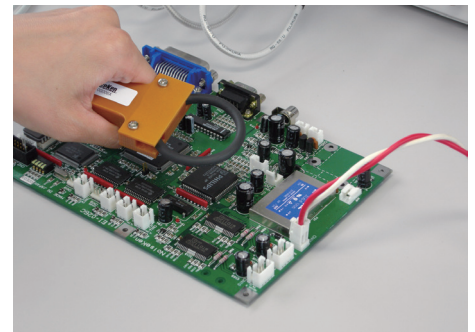

Radiation probe

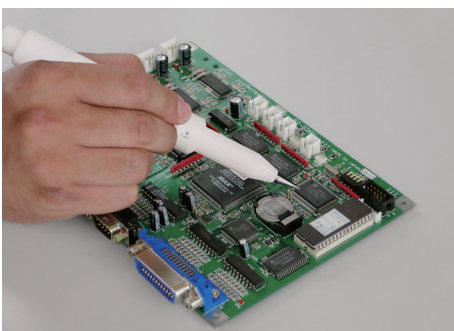

Noise injection probe

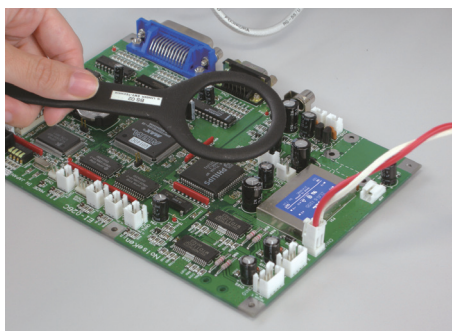

H2-B

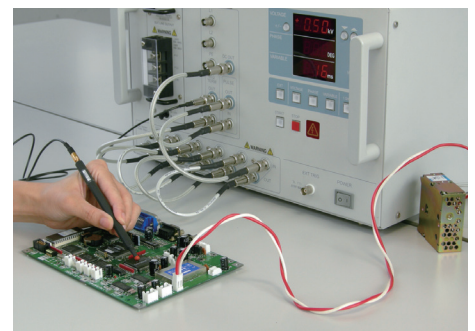

H2-B

Pulse Injection Cable MODEL : 02-H1834



This cable is used for direct noise injection in combination with an Impulse Noise Simulator.

* It cannot be used for applying current to places where current flows, such as power lines.

Options

INS Direct Injection Capacitor MODEL : 01-00047A



A unit for directly applying the pulse output of the Impulse Noise Simulator without passing through the simulator's internal CDN. A coupling capacitor same with the CDN is built-in. It can be used when the power supply capacity of the test product is a weak current such as a DC5V line, and when it cannot be energized when passing through the simulator's CDN.

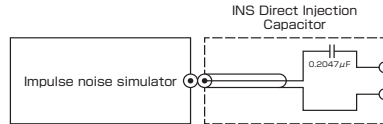

Item	Specifications
Coaxial connector	NMHV
Connector	M6 ring crimp terminals
Dimensions / weight	80×80×150 mm (protrusions excluded) / 400g

Injection Unit MODEL : IJ-4050



Unit allowing noise injection to power supply lines of EUT up to 3-phase 5 lines (L1, L2, L3, N, PE) in combination with main units of INS series. Setting for Normal mode and Common mode is simple and easy with change of the connectors configurations.

In case of the combination with INS-4020 / 4040 / S220, test synchronized with EUT lines can be conducted.

Parameter	Specifications
Input impulse voltage	Max. 8kV without 50Ω termination Max. 4kV with 50Ω termination
EUT power capacity	3-phase 5 lines (L1, L2, L3, N, PE) AC415V 50A (Unavailable for DC) AC415V between L1-L2, L2-L3, L3-L1 AC240V between L1, L2, L3 - N
Injection phase switching	By coaxial connectors L1, L2, L3, N, PE
Coupling modes	Normal / Common (Setting with short plug connection)
Zero cross detection	Detects between L1 - L2 and outputs the synchronization signal from SYNC OUT terminal
EUT line protection circuit	Detects current in L1, L2 and L3 lines and breaks L1, L2, L3 and N lines
EUT line input terminal	Terminal block, screw connection
EUT line output terminal	Exclusive contact for φ6
Coupling Attenuation characteristics	≤-10db 10kHz-1GHz without load
Residual voltage at input	≤450V Residual voltage without load when 4000V impulse is injected with 50Ω termination
Termination resistance	N/A (Termination resistance in Impulse Noise Simulator is applied)
Power supply	AC100V-240V±10% 50 / 60Hz 20VA Max
Operating temperature / humidity range	15~35°C 25~75%
Dimensions / Weight	(W)430×(H)199×(D)535mm (Protrusions excluded) / Approx 25kg

Injection Unit MODEL : IJ-5100Z



Unit allowing noise injection to power supply lines of EUT up to AC480V / 100A 3-phase 5 lines (L1, L2, L3, N, PE) in combination with main units of INS series. In case of the combination with INS-4020 / 4040 / S220, test synchronized with EUT lines can be conducted.

Parameter	Specifications
Input impulse voltage	Max. 8kV without 50Ω termination Max. 4kV with 50Ω termination
EUT Line	3-phase 5 lines (L1, L2, L3, N, PE)
Maxium voltage of EUT line	AC 480V
Maxium current of EUT line	100A
Line synchronization output	1/2 of EUT line input voltage
Through characteristics	within -10db in 10kHz-1GHz
CDN power supply	AC 100~240V ±10% 50 / 60Hz
Dimensions / Weight	(W)488×(H)520×(D)825mm (Protrusions included) / Approx 115kg

Circuit Breaker Box MODEL : 18-00072A (20A) / 18-00073A (50A)

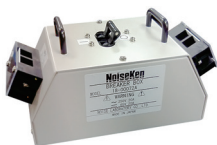

A breaker box allowing to cut off the line between the Simulator and the power supply side by using it in combination with the INS-S220/S420/IJ-4050/AT450.* Connection requires processing of the connection cable. Contact us for more details.

Parameter	Specifications (18-00072A)	Specifications (18-00073A)
Rated Voltage	AC250V 50/60Hz DC65V	AC240/415V 3 phase 4 wire Y-connection, 50/60Hz AC240V : Line-N (neutral) AC415V : Line-Line
Rated Current	20A	50A
Switching durability	over 10,000 times (rated open/close 6,000 times, no load open/close 4,000 times, frequency 6 times/minute)	
Neutral pole (N pole)	N/A	The neutral pole does not trip by itself. The neutral pole does not open before the other poles and does not close after the other poles.
Operating temperature, humidity	15 ~ 35°C 25 ~ 75% (no condensation)	
Dimensions	(W)180×(H)92×(D)100mm (excluding protrusions)	(W)180×(H)92×(D)120mm (excluding protrusions)
Weight	0.75 kg	1.2kg

Options

Isolation Transformer MODEL : TF-2302P



Model TF-2302P is a single-phase isolation transformer rated AC240V/30A with dielectric strength of 4kV. For safety reasons, an isolation transformer is indispensable for AC powered testing for equipment.

Parameter	Specifications
Maximum input voltage	Single phase AC240V Max (50/60Hz)
Maximum output current	30A Max
Dielectric strength	Primary winding to core AC4kV (1 minute) Secondary winding to core AC4kV (1 minute) Primary to secondary windings AC4kV (1 minute)
Insulation resistance	100MΩ or more at DC500V
Dimensions / Weight	(W)350×(H)475×(D)400mm (Except for eye bolt and handle) / Approx. 60kg
Accessories	AC single phase line input cable (5.5sq 3-line 3m, One end: with a stick-type soldering terminal, The other end: without terminal): 1pc., PE/FG cable (3.5sq 3m Both ends: with a φ6 ring-type soldering terminal) : 1pc. Instruction Manual: 1pc. AC single phase line output cable (3.5sq 3-line 2m, One end: with stick-type soldering terminal, The other end: with a φ5 ring-type soldering terminal): 1pc.

Isolation Transformer MODEL : TF-6503P, TF-6633P



Model TF-6503P, TF-6633P are three-phase isolation transformers rated AC 600 V / 50 A (TF-6633P 63A) and dielectric strength of 4 kV. For safety reasons, an isolation transformer is indispensable for AC powered testing for equipment.

Parameter	TF-6503P Specifications	TF-6633P Specifications
Maximum input voltage	Single / Three phase AC 600 V Max (50/60 Hz)	
Transformer wiring method	Star wiring	
Maximum output current	50 A Max	63 A Max
Dielectric strength	Primary winding to core AC 4 kV (1 minute) Secondary winding to core AC 4 kV (1 minute) Primary to secondary windings AC 4 kV (1 minute)	
Insulation resistance	100 MΩ or more at DC 500 V	
Dimensions / Weight	TF-6503P: (W)500×(H)640×(D)700mm (Eye bolts and handles excluded) approx. 350kg TF-6633P: (W)500×(H)661×(D)700mm (Eye bolts and handles excluded) approx. 400kg	
Accessories	AC three-phase line input cable (14sq (22sq for TF-6633P) 4-line 3m, One end: with a stick-type soldering terminal, the other end: without terminal):1 pc. PE cable (8sq 3m, One end: with a φ6 ring-type soldering terminal, The other end: without terminal): 1 pc. PE/FG cable (8sq 3m Both ends: with a φ6 ring-type soldering terminal): 1 pc. Instruction Manual: 1 pc. AC three phase line output cable (14sq (22sq for TF-6633P) 4-line 2m, One end: with stick-type soldering terminal, The other end: with a φ5 ring-type soldering terminal): 1pc. PE cable (8sq 2m, One end: with a φ6 ring-type soldering terminal, The other end: with a φ5 ring-type soldering terminal): 1pc.	

Noise Canceller Transformers NCT series



These series have excellent attenuation characteristics for impulse noises. Used for line input insulation during impulse noise testing.

MODEL	Primary / Secondary Voltage	Rated current	Frequency
NCT-160	120V	5A	50/60Hz
NCT-1240		20A	
NCT-2240	240V	10A	

Line input cable MODEL : 05-00160A Line output cable MODEL : 05-00161A



The connection cable between noise impulse simulator and noise canceller transformer on primary winding. Please inquiry us for details.

Description	MODEL	Specifications
Line input cable	05-00160A	Single phase 20A, 3m Cabytre cable, Ring terminal end - Stripped end (termination at the customer's side)
Line output cable	05-00161A	Single phase 20A, 2m Cabytre cable, Ring terminal end - Ring terminal end

Options

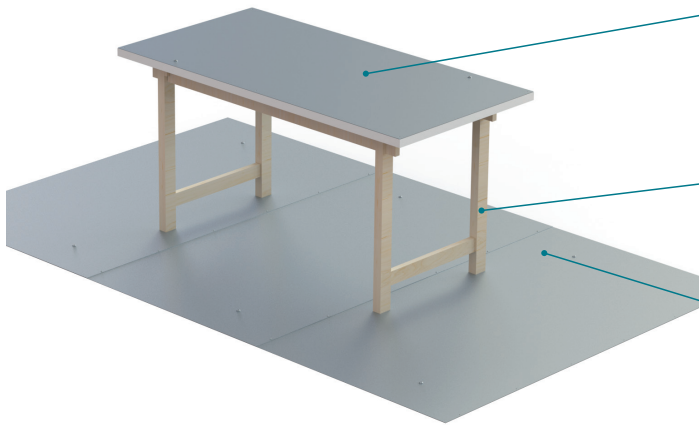

Horizontal Coupling Plane (HCP) MODEL : 03-00020A

Metal plate placed on the table for the testing of tabletop EUT.
(W)1600 × (D)800 × (t)1.5 mm × 1 sheet (made of Aluminum)
* Used as a horizontal coupling plane in ESD testing and also can be used as a ground plane

Test Table MODEL : 03-00039A

Wooden table to be used for the test to equipment (EUT) and devices under test (DUT).
(W)1600 × (H)800 × (D)800 mm

Ground Reference Plane (GRP) MODEL : 03-00007A

Ground plane to be placed under the wooden table.
(W)1800 × (D)1000 × (t)1.5 mm × 3 pcs. in 1 set (made of aluminum)

Insulating Block MODEL : 03-00054A



Blocks to float (isolate) wirings of EUT from GRP.
(W)300 × (D)300 × (H)50mm, 5 pcs. in 1 set

Material: Polyethylene foam

Insulating support MODEL : 03-00024A



Used for floating EUT 10cm above the ground plane in case of testing to floor-standing EUTs.

Size : (W)1200 × (D)1200 × (H)100mm
Material : Wooden
Withstanding loads : 500kg

Cubic Insulating Block100 MODEL : 03-00029A



Used for floating EUT 10cm above the ground plane in case of testing to floor-standing EUTs.

Size : (W)100 × (D)100 × (H)100mm
Material : Wood
Withstanding load: 500kg

SG Cable MODEL : 05-00103A



Braided wire cable to connect between SG terminal of the main unit and the ground reference plane.

Length : 0.1m

USB Optical Module Kit MODEL : 07-00022A



Connection adapter used for remotely controlling the simulator from a PC.
Equipped with USB-Optical conversion fiber optic cable (5m)

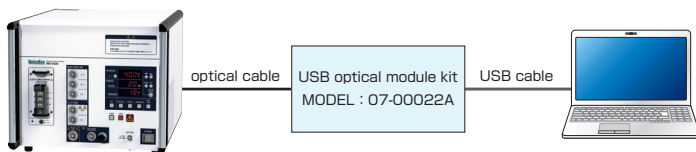

[PC control image of INS-S420 only]

Allows controlling the pulse output voltage, pulse width, phase angle and repetition period of the Simulator's main unit, however application phase and return phase switch control is not available.

SG Connection Plate MODEL : 03-00112A



Metal plate connecting simulator's SG and ground plane. Screw attaching to the Ground Plane is not required contributing to simulator's mobility.
*for INS-S220/S420

USB optical interface unit MODEL : 07-00023A



Connection adapter used for remotely controlling the simulator from a PC. Equipped with USB-Optical conversion fiber cables 5m × 4 (ch)

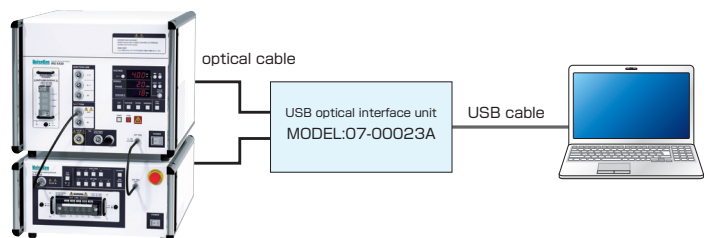

[PC control image of both INS-S420 and IJ-AT450]

Allows controlling the pulse output voltage, pulse width, phase angle and repetition period of the Simulator's main unit, and also application phase and return phase switching is available.

IMPULSE NOISE TEST OVERVIEW

(Square Wave) Impulse Noise Test Method

Power supply lines test method

- ① Connect the power supply line for EUT to EUT LINE INPUT on the simulator main unit (hereafter referred to as the Main Unit) through an isolation transformer.
- ② Lay a ground plane and insulation sheet under the main unit and the EUT, and ground the ground plane for safety.
- ③ Connect the power supply cable of EUT to the main unit (fold and bind the cable to shorten it if too long)
- ④ In the common mode test, connect the SG short plug, and connect the SG terminal of the main unit and the ground plane as well as the FG terminal of the EUT (if there is a terminal) and the ground plane with a short and reliable braided wire with low impedance for high frequencies.
- ⑤ Connect 50Ω TERM OUT connector to connector of phase (L1 or L2, PE if necessary) the noise is intended to be injected with coaxial cable.

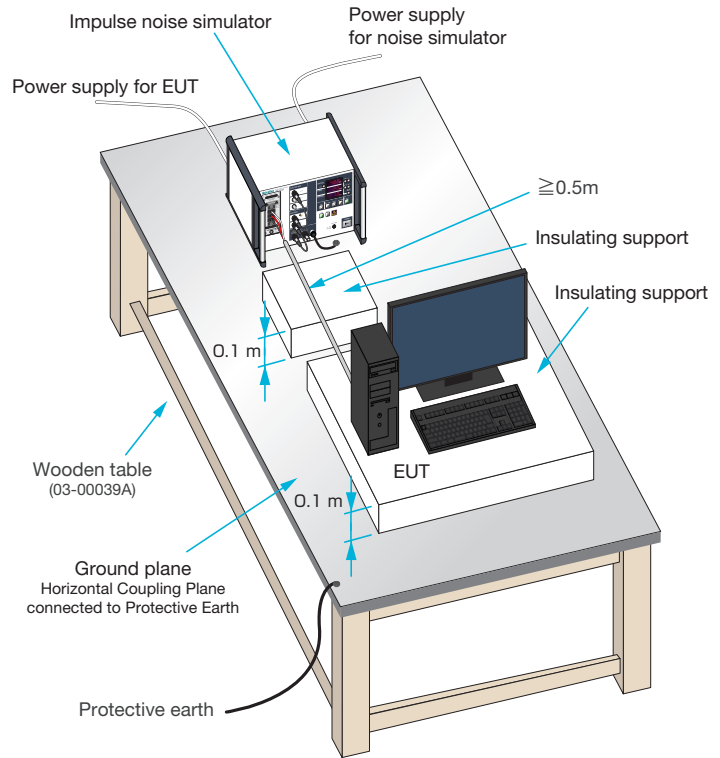

Interconnection lines test method

- ① Lay a ground plane and insulation sheet under the main unit and the EUT, and ground the ground plane for safety.
- ② Open the coupling adaptor 15-00014A (option) and clamp interface cable with the adaptor. Connect connector of the adaptor to PULSE OUT of the main unit. Connect the other connector of the adaptor to 50Ω TERM IN of the main unit.
- ③ Connect power supply cable of EUT to any power source since no high voltage pulse is injected in this test.
- ④ Connect the Main Unit's SG terminal and FG terminal of EUT to the ground plane.

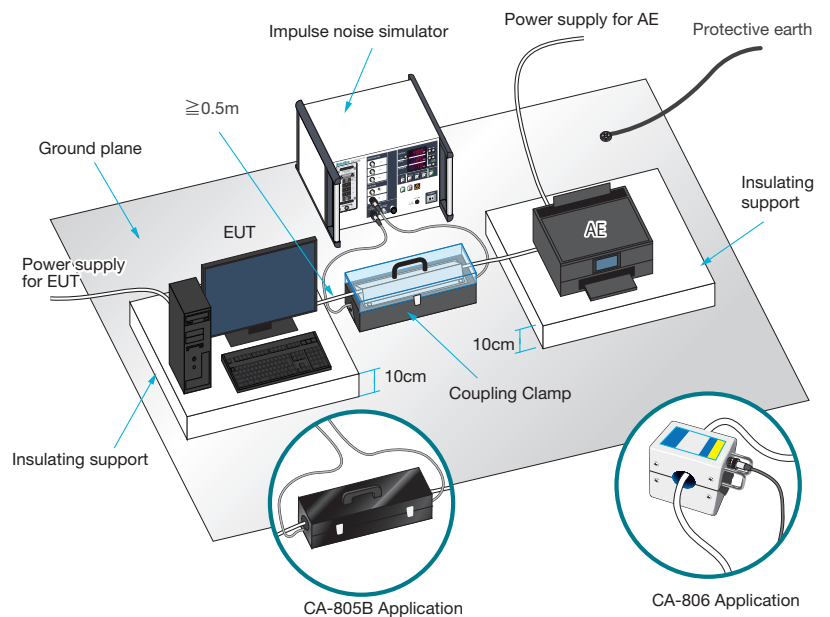

IMPULSE NOISE TEST OVERVIEW

WAVEFORM OBSERVATION

Waveform observation using the 00-00017A attenuator for waveform observation.

- ① Connect the PULSE OUT of the Main Unit and the input connector of the 00-00017A waveform observation attenuator with the (HN(P)-NMHV(P)) coaxial cable included with the 00-00017A waveform observation attenuator. Connect the output connector of 00-00017A and the included coaxial cable (N(P)-BNC(P)) to the input of the oscilloscope. If necessary, insert an attenuator between them.
- ② The output impedance of 00-00017A is 50Ω, so set the oscilloscope input to 50Ω termination.
- ③ Start the Main Unit.

-Reference- The reason to use an attenuator if necessary

The impedance of the Main Unit is 50Ω. Since the load resistance of 00-00017A is also 50Ω, if the voltage is set to 4,000V, then $4000V \times (50\Omega/50\Omega+50\Omega) = 2000V$ output can be confirmed, and the attenuated by 00-00017A voltage of 20V is input to the oscilloscope. Some oscilloscopes cannot accept 20V input when measuring with 50Ω termination, so it is necessary to insert a 20dB attenuator for further attenuation. (In this case, the input is 20V → 2V due to the attenuation ratio of 10:1)

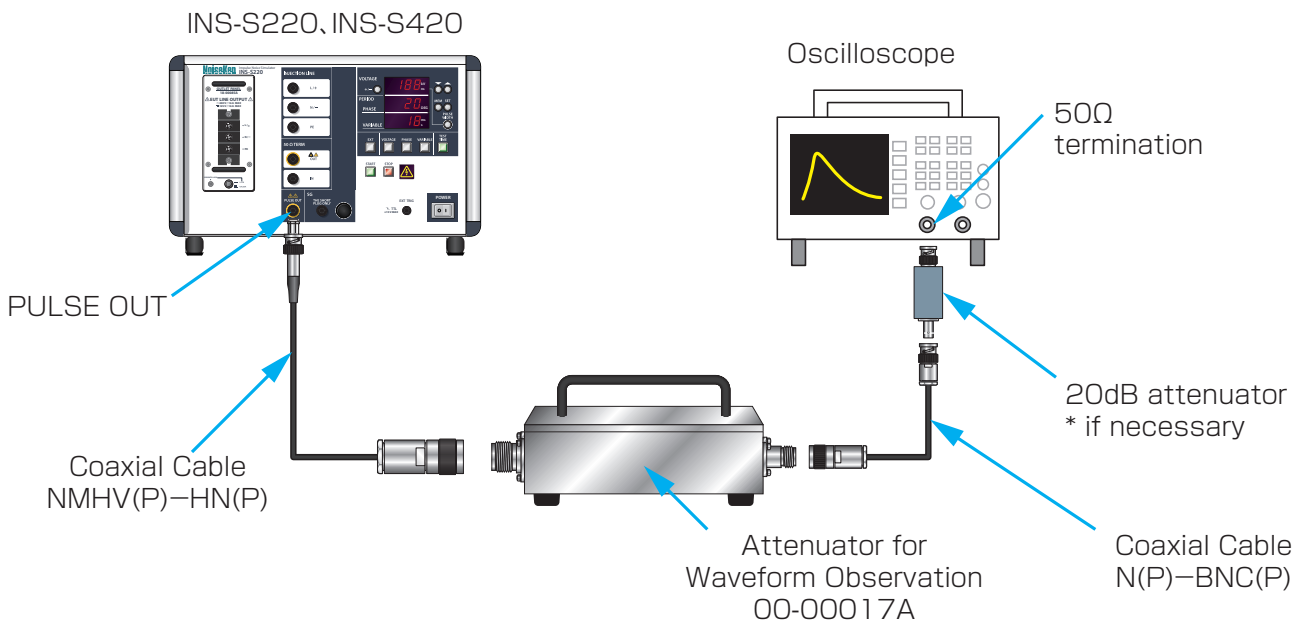

Output waveform image

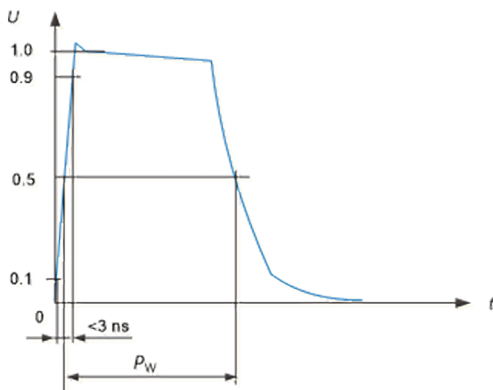

Output waveform (rise time and PW specification)

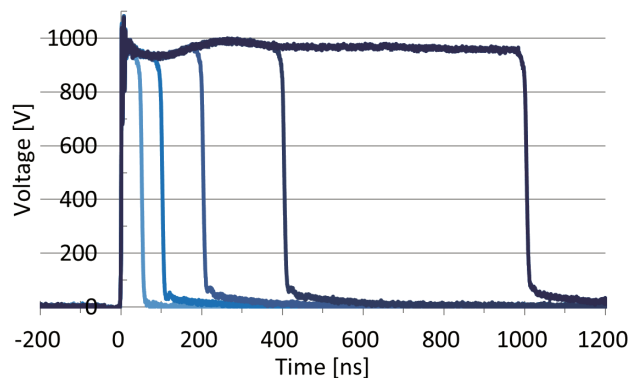

Output waveform (50ns, 100ns, 200ns, 400ns, 1000ns)

NoiseKen

NOISE LABORATORY

NOISE LABORATORY CO.,LTD

<http://www.noiseken.com>

International Sales & Marketing Section

1-4-4 Chiyoda, Chuo-ku, Sagamiara City, Kanagawa Pref. 252-0237 Japan

TEL: +81-(0)42-712-2051 FAX: +81-(0)42-712-2050

E-mail : sales@noiseken.com



[Note] ● It is prohibited to copy or reprint all or part of this catalog without permission. ● Product specifications and appearance are subject to change without notice. ● The model name and price may change or production may be discontinued due to various reasons. ● Please contact our sales representative for any questions regarding your order or contract. ● We may not be liable for any responsibilities or liabilities that arise without confirmation. ● Company names and brand names listed in the catalog are trademarks or registered trademarks. ● Our products listed in the catalog are commercial equipment and devices that are supposed to be used under the supervision of a supervisor who has sufficient knowledge in use. ● It is not a product designed and manufactured for general households and consumers. ● Due to printing reasons, there may be differences in color and texture between the photos listed in the catalog and the actual product. ● We make our best efforts to provide accurate information about the contents of this catalog, but if you notice any typographical errors, please contact our sales office.

Authorized representative